

Engineering for Advanced Radar and Electromagnetic Spectrum Operations

NEW ERA OF SECURITY



Preface

Defense forces in the modern world are progressing toward a new era of electromagnetic spectrum operations (EMSO). The availability and rapid evolution of technology results in a conflict domain filled with advanced threats and foes. Military forces strive to excel in this spectrum across all domains of land, sea, air and space. The electromagnetic (EM) spectrum is used to detect, deceive, and disrupt the efforts of any unwanted threat activity.

Electronic warfare (EW) generally includes anything operating in the radio frequency (RF). EM operations target many aspects of the EW environment, ranging from radars and jammers to military communications. EW systems use the EM spectrum to support communications, sensing, and defense. Modern EW systems continuously evolve as new and emerging technologies transform these systems. Digital and programmable RF equipment, such as software-defined radios, adds complexity. In addition, radars can quickly change waveforms, making it challenging to locate, identify, and confuse hostile emitters. These trends impact every aspect of EW. You can address these evolving needs with flexible, scalable threat simulation and analysis solutions.

This book outlines the core aspects of radar and EMSO engineering. Starting with broad fundamentals, it covers the technology shift from analog systems to faster digital systems. From the operational perspective, these systems deploy wideband frequencies. Signal formats and modulation schemes — pulsed and otherwise — continue to grow more complicated, and this demands wider bandwidth. Advanced digital signal processing (DSP) techniques are used to disguise system operation and avoid jamming.

This volume explores all possible challenges and scenarios at the design and simulation, component, subsystem, and system levels. The design section highlights the importance of model-based engineering and the significance of simulation tools, which can help increase accuracy at much lower cost. The subsequent sections take a bottoms-up approach, covering critical amplifier measurements, material measurement, filters, mixers, and up/down converters. At the subsystem level, the transmitter and receiver sections highlight how the latest signal generators and signal analyzers can help engineers perform validation in their labs using software. The last section provides a complete overview of the system level, addressing the importance of software intelligence, data analysis, and emerging cyber needs.

Offering a combination of leading technical expertise and a heritage in measurement science and innovation, Keysight works closely with research, design, and manufacturing companies to support the development and evolution of new technologies. We offer solutions to address all phases of development and support for radar and EW systems, from design to verification through long-term sustainment. At Keysight, we take pride in our leadership as a commercial collaborator, creating and delivering the rapidly adaptable solutions you need for success in your current programs and to achieve your objectives for future capabilities.

Table of Contents

Section 1: Prepare for a New Era of Security Threats

Chapter 1 - Introduction & Evolving Challenges in Radar and EW	6
--	---

Section 2: Virtual Prototyping using Design Tools

Chapter 2 - Radar and EW Development Using Model-Based Engineering	16
Chapter 3 - Radar and EW System Design and Interference Analysis	26
Chapter 4 - Simulation and Verification of Pulse Doppler Radar Systems	41
Chapter 5 - Applying Ultra-Wideband Technology in Radar and EW Systems	57
Chapter 6 - Dealing with the Complexity of Phased-Array Systems	63
Chapter 7 - Generating Signals for Radar and EW Design and Verification	75
Chapter 8 - Virtual Flight Testing of Radar System Performance	88

Section 3: RF Component Test and Verification

Chapter 9 - Figures of Merit Aid Amplifier Distortion Assessment	96
Chapter 10 - Determine Your Optimal Noise Figure Measurement Method	101
Chapter 11 - Select the Appropriate Phase Noise Test Solution	106
Chapter 12 - Measure S-Parameters with Increased Confidence	119
Chapter 13 - Characterizing Frequency Translating Devices	135
Chapter 14 - Expand Insight into Nonlinear Behavior and Modeling	145
Chapter 15 - Methods for Measuring the Dielectric Properties of Materials	148

Section 4: Radar and EW Subsystem Test

Chapter 16 - Signal Source Essentials- Parameters, Technologies, and Methods	159
Chapter 17 - Measuring Radar and EW Signals.....	182
Chapter 18 - Testing TR Modules Efficiently.....	208
Chapter 19 - Understanding the Techniques for Antenna Testing.....	222

Section 5: System Level Radar and EW Test

Chapter 20 - Avoiding 5G Coexistence and Effectively Simulating Background Signals	236
Chapter 21 - Validating Jammer Effectiveness.....	245
Chapter 22 - Radar and EW Signal Recording and Analysis	251
Chapter 23 - Electronic Intelligence	275
Chapter 24 - Test System Calibration and Alignment.....	279
Chapter 25 - Field Testing, Sustainment, Uptime-Service, and Support	283
Chapter 26 - Software Testing for Radar & Electronic Warfare Systems.....	294
Chapter 27 - New Age Requirements of Cyber Security	299

Section 6: Gain Confidence, Achieve Realism

Chapter 28 - Achieve Realism and Accuracy in EM Spectrum Operations	302
---	-----

Appendix

Acronyms	311
Additional Resources	314

Section 1

Introduction & Evolving Challenges in Radar and EW



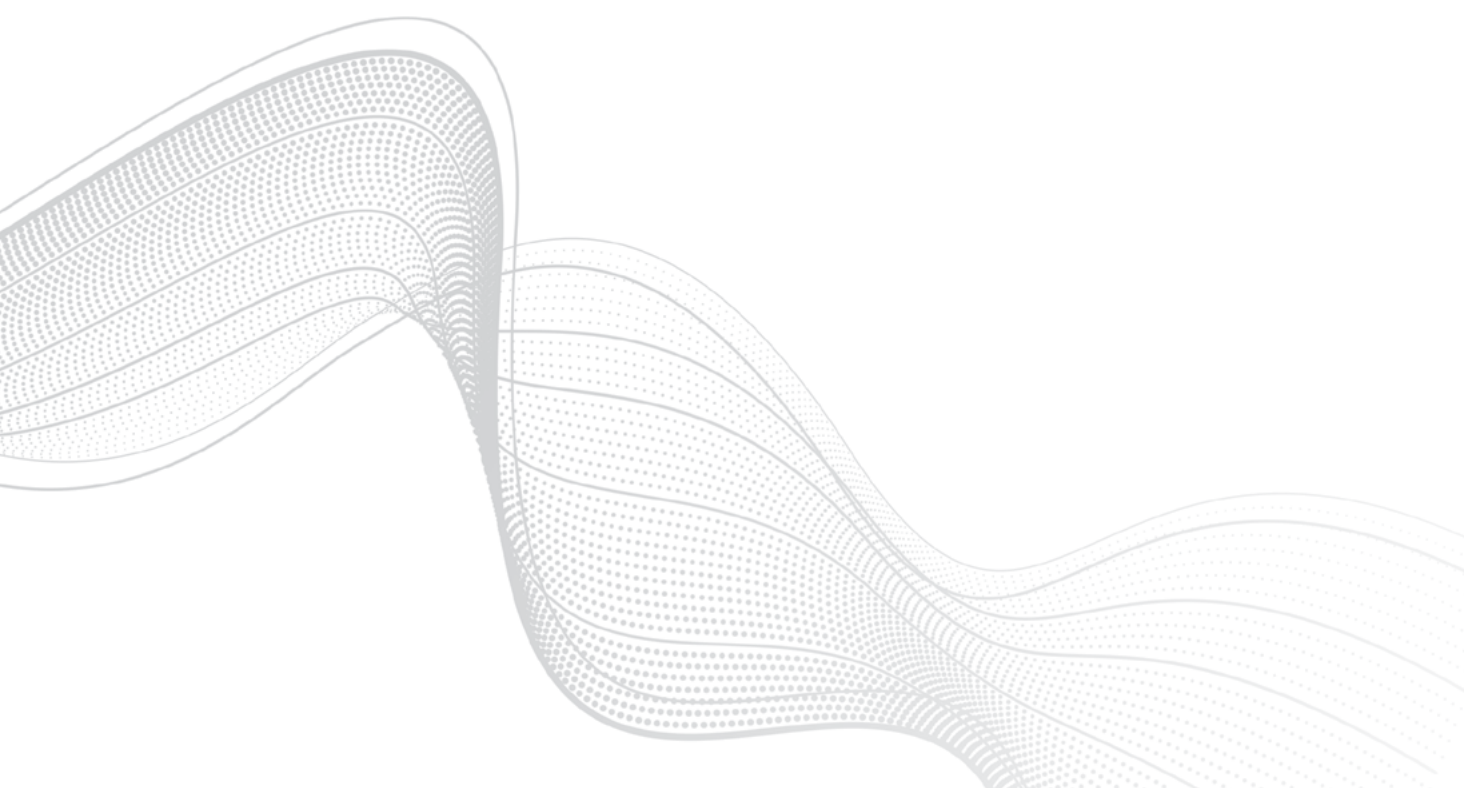

Chapter 1 Sophisticated Threats Raise Stakes in Electronic Warfare Conflicts

Most modern military conflicts begin beyond the sight of the naked eye. Through all domains – land, air, sea, space, and cyberspace – military forces fight for dominance of the electromagnetic (EM) spectrum. These forces use the EM spectrum to detect enemy forces, deceive them, or disrupt their efforts. With different forms of electronic attack, they can weaken, disable, or even devastate their enemy’s spectrum usage. The adaptive nature of these EM spectrum operations makes it difficult to stay a step ahead of them. At the same time, widely available and greatly improved technology translates into more adversaries in the electronic warfare (EW) domain. Today’s EW environment increasingly features unknown actors producing responsive, unpredictable threats. Countermeasures must meet or exceed that pace of rapid development to prevail in the EM spectrum.

EW, defined as warfare in the EM spectrum, generally includes anything operating in the radio frequency (RF). Electromagnetic operations target many aspects of the EW environment, ranging from radars and jammers to military communications. Anything that communicates over the air is a potential target. EW systems use the EM spectrum to support communications, sensing, and defense. Disarming these capabilities means denying an adversary's ability to communicate or navigate. Signal intelligence systems also gather intelligence or find targets. In all applications, those who perform spectrum maneuvers most quickly achieve an advantage, as modern threats work to ensure success using responsive, unpredictable behavior.

Threats do not have to conduct a visible attack but instead cause failure in communications, coordination, and other operations. Due to the convergence of the following trends, threats have grown increasingly in number and sophistication:

1. Availability of technology: 10 years ago, very few players dominated this battlefield. The technological capabilities and investments required to dominate in EW prohibited others from developing competing EW capabilities. As commercial electronics became cheaper and more available, adversaries of all sizes entered the EW arena. Now, even smaller adversaries potentially have a competitive threat arsenal, making the threat environment more dangerous and unpredictable. With the barrier to entry so low, anyone with the right skill and knowledge can secure enough equipment to be a threat.

2. Software-defined radio (SDR) systems: Originally, SDR translated to a reconfigurable radio-based only software. Analog-to-digital conversion occurred directly at the antenna. Modern SDRs often take more complex forms, changing their operating frequency, modulation, operating bandwidth, and network protocol without having to change the system hardware. As speeds increase for both digital signal processing (DSP) and analog-to-digital converters (ADC), more signal processing occurs digitally. By leveraging such systems, military forces can more easily upgrade their threat systems. The rapid pace of change for commercially available dual-use technologies and software-defined systems drives much of the diversity and complexity of future threats.

3. Artificial intelligence (AI): The pace of change for commercially available dual-use technologies and software-defined systems drives both the diversity and complexity of future threats. With the addition of AI, those threats also learn from each conflict and are more likely to prevail in the future.

Types of EW Threats

Threats of the past were static – consistent in appearance and behavior. Today's threats are responsive, changing their behavior based on the scenario. If an adversary is jamming a reactive threat, for example, it will switch frequencies or take another action to elude that jamming. Adversaries must now assume that a threat might change and prepare to react accordingly.

Cognitive and Adaptive

Cognitive or adaptive threats change and adapt over time. Although people use these terms interchangeably, many levels of adaptability exist. Most of them do not come near the capabilities of cognitive EW. Cognitive EW systems use machine learning to enter an environment with no prior knowledge of the adversary's capabilities and rapidly understand the scenario. By doing something that makes the adversary's system react, they can quickly evaluate it and develop an effective response suited for that particular adversary's system.

In contrast, adaptive solutions cannot rapidly grasp and respond to a new scenario. For example, an adaptive radar senses the environment and alters its transmission characteristics accordingly, providing a new waveform for each transmission or adjusting pulse processing. This flexibility allows an adaptive radar to enhance its target resolution. Many adversary systems require only a simple software change to alter waveforms, which adds to the unpredictability of waveform appearance and behavior. Military forces struggle to isolate adaptive radar pulses from other signals, friend or foe.

Much adaptive and cognitive development is in response to anti-access / area denial (A2/AD) threats. A2 threats prevent or hinder the deployment of ally forces into the conflict zone. For example, these threats may do something to force the adversary to engage from a less effective distance. Successful A2 threats prevent access or even passage of ally forces.

In contrast, AD threats take actions that impede friendly operations. These threats work to limit or eliminate an adversary's ability to respond to its allies or other friendly forces. Examples of such threats include attack vessels or aircraft, as well as missiles. AD threats affect the operations within the domain. As these threats grow increasingly adaptive, their opponents must respond to them in a much shorter time.



Impact of Machine Learning

With AI, intelligent machines work and respond much like humans to perform more complex tasks using capabilities like signal recognition. Machine learning takes AI one step further, allowing machines to continuously learn from data and adapt as a result. These computers learn over time at a very rapid rate. Threats using machine learning continue to learn from every conflict and determine ways to prevail against future countermeasures. As the computer decides how to alter behaviors, evolution occurs without the need for human interaction. Due to the unpredictable behavior of the threat system, even the people who implemented it cannot foretell its exact behavior.

As threat systems advance with machine learning technology, they will adapt and alter their behavior or course of action at an increasingly rapid rate. For example, if a radar is trying to track a jet, the adversary's countermeasures may stop it from succeeding. Using machine learning, that radar would repeatedly try new approaches to achieve success.

The Countermeasure Response

EW systems respond to threats with countermeasures. By using the EM spectrum or directing energy, forces can control the spectrum to either attack or defend. An electronic countermeasure (ECM) or attack prevents an opponent from leveraging the EM spectrum to succeed in their operations. The goal is to weaken, neutralize, or destroy the enemy's capabilities with attacks on people, equipment, or buildings and locations. These attacks use EM, directed energy, or anti-radiation weapons.

An ECM is an electrical or electronic device designed to trick or deceive radar, sonar, or other detection systems, like infrared (IR) or lasers. It may be used both offensively and defensively to deny targeting information to an enemy. The system may make many separate targets appear to the enemy or make the real target appear to disappear or move about randomly.

Most air forces use ECM to protect their aircraft from attack. Military ships also deploy ECM, while some advanced tanks recently began leveraging them to fool laser/IR guided missiles. Frequently, an ECM is coupled with stealth advances to simplify the work of the ECM systems. Offensive ECM often takes the form of jamming. Self-protecting (defensive) ECM includes using blip enhancement and jamming of missile terminal homers.

As threats grow more sophisticated, countermeasures must become just as sophisticated. Radars go through a step of evolution and emerge more sophisticated. The role of countermeasures is to counteract these developments, so they go through their evolution to again take the lead. As the two sides compete against each other, every step increases complexity.



Jamming Techniques

A radar works by sending out a pulse. That pulse reflects off things in the environment and bounces back. If you send out a pulse in the air and it encounters a fighter jet, RF energy bounces off that jet, returns to your radar receiver, and you see the return. That return is known as an echo return or a skin return of a platform. You jam the radar with broadband noise by putting a lot of RF energy into the receiver at the same time that skin or echo return hits the receiver. The skin return is not detectable because of the high energy levels.

With range gate and velocity gate pull offs, the returned pulse looks like the skin return, but it changes it slightly. It makes it look like the direction that that aircraft is flying is different than what it is. For example, it could appear that the reflected object is moving away instead of toward you. As a result, you lose the tracking on it.

With digital radio frequency memory (DRFM) techniques, you take RF in, digitize those signals, and create new RF energy based on the pulse you receive. You use this very fast turnaround technology to create multiple false targets.

Stealth technology uses a different approach. It combines the geometry of the plane with materials that do not reflect RF energy well. When radars send out the pulse, they do not get a good skin return back. The combination makes it challenging for radar to detect stealth units.

Countermeasures continue evolving more rapidly to stay ahead of threats. Many of these developments focus on DRFMs and the use of more sophisticated digital signal processing (DSP). As DSP grows more scalable and powerful, more intelligence can be added to EA receivers. To learn how to respond to new threats, these systems also use machine learning or AI-type applications.

In the increasingly crowded spectrum, uncertainty grows over the guaranteed success of any electronic countermeasure. To evaluate electronic attacks or electronic countermeasures, you should generate the threat and analyze your response to it. If accurate threat detection and analysis are enabled, your systems will respond to threats with the right countermeasures. This ECM analysis tells you if you can prevail in your electromagnetic spectrum operations.

Preparing for the Future

Due to the abundance of new, modern, and responsive threats, military forces vie for control of the EM spectrum. Spectrum dominance enables them to detect, deceive, and disrupt enemy forces while protecting their military. Military forces must constantly innovate their EW threats and countermeasures to dominate the EM spectrum and stay in the leading position. To keep pace with the ever-changing threat environment, military forces demand flexible, scalable solutions. A risk mitigated today may not be an issue six months from now. As a result, military forces continue to face new threats from enemy forces.

Incomplete, disaggregated data prevents military forces from attaining or creating a clear threat picture. They lack a methodology against which to test these threats. This issue stems from traditional EW threat simulation systems. They use databases of known threats, which usually have associated countermeasures. Such classified lists of known targets are no longer as effective as they quickly fall out of date. These systems were not built to identify and isolate threats in the EM environment and determine countermeasures on the fly.

Even when capable of processing new signals, traditional EW threat simulation systems involve a very time-consuming process. For example, military forces collect information from the field about a type of signal, such as frequency or pulse repetition interval (PRI). They send that information to a lab, where it is analyzed to gather more information and develop countermeasures. Months pass before that information is available in the system for use.

In the future, adversaries will have a more complete picture of operations. Building on the past decade's transformation, the next 10 to 20 years promise to deliver faster, more evolved technology developments. Many predict that machine learning and artificial intelligence will drive powerful, continuous evolution in EW. The EW threat environment will leverage drastic processing improvements like using multiple devices to provide more information in less time. Sensing technologies will also play a larger role, gathering information about the conflict zone. New coding techniques already result in increasingly complex, interconnected, and correlated sensors.

These technology innovations will spawn knowledgeable, newly responsive threats that find novel ways to gain power in the EM spectrum. While the technologies will continue to evolve, and new threats emerge, one constant remains – the military force that achieves and maintains spectrum dominance will dominate the EW domain.

Additional Resources:

For more information on Keysight's radar and EW solutions, visit www.keysight.com/find/AD



<https://www.keysight.com/see/radar-ew-system-design>

Section 2

Virtual Prototyping Using Design Tools



Introduction

Gone are the days of simple design. Every year, designers push new limits: higher output power, better efficiency, smaller components, and increased levels of integration.

With complex design comes new challenges. Designers spend hours setting up and running simulations. Mountains of data wait to be measured and analyzed. Engineers need to create workarounds to connect multiple design tools. Meanwhile, wireless standards are evolving quickly. To keep up with the strong demands of modern technology, a new approach is essential.

The Next Generation of Electronic Design and Test

Connected, Agile Design and Test is a transformational way to approach the development of electronic systems. It combines new software, workflows, and powerful automation tools in a way that transforms processes and yields substantial productivity and equipment utilization improvements.

The approach moves organizations from siloed design and test steps to agile, connected workflows. The benefits mirror those of agile software design and DevOps:

- faster device design
- translation of design parameters into test requirements
- execution and validation of test results

When coupled with automation, what results is a new development culture known as TestOps. ([Read more in The TestOps Manifesto: A Blueprint for Connected, Agile Design and Test.](#))



The Transformation Starts with Design

There is a tremendous opportunity to reduce time-to-market across the design and simulation phases of the electronic product development lifecycle. Most challenges slowing the lifecycle today can be distilled down to data movement and tool integration. Information sharing across the workflow is one of the biggest challenges for design and test engineers. 9 out of 10 companies revealed that correlating test result data with simulation takes months.

The reason data correlation takes so long is primarily because of the numerous tools used throughout the development lifecycle. Over 50 percent of designers use more than 5 different tools for simulation and design. The software tools are not integrated and require hours of coding each week to enable data sharing. The magnitude of that integration effort is amplified by the fact that nearly every company is devoting more resources to the maintenance of in-house tools. Designers are looking for an integrated solution that leverages shared data to accelerate their electronic design.

The Keysight Solution

Keysight offers a collection of electronic design automation software tools that accelerates product development by reducing the time engineers spend in the design and simulation phase. Its libraries and customized simulators reduce setup time. The software seamlessly integrates circuit design, EM simulation, layout capabilities, and system - level modeling, reducing time spent in importing and exporting designs and fixing errors associated with changing tools. Improvements in data analytics allow for faster examination and expeditious design decisions. Automation improvements reduce manual work. This chapter will cover how to bring efficiencies into the RF and microwave design flows, shortening the design cycle and reducing project delays, as well as, provide a series of examples on how to apply this design flow for radar and EW systems.



<https://www.keysight.com/see/radar-ew-system-design>



Chapter 2

Radar and EW Development Using Model-Based Engineering

This chapter describes a design methodology and flow that is well suited for use in model-based engineering. This is an approach to engineering that uses models as an integral part of the technical baseline that includes the requirements, analysis, design, implementation, and verification of a capability, system, and/or product throughout the acquisition lifecycle. It is targeted at system engineers, directors of engineering and equivalent job functions who are involved in the development of radar and EW systems.

Introduction to Model-Based System Engineering (MBE)

The radar/EW lifecycle comprises of development, deployment, maintenance, and enhancement for future requirements; each must be considered upfront for developing an effective and efficient system and to achieve low cost of ownership. Highly complex radar and EW systems have been developed and deployed in complex environments with great performance and superb results since World War II. Since then, however, signal complexity has gone up by several orders of magnitude and new technological innovations have been introduced to realize ever increasing capabilities. These two aspects alone make the radar and EW systems' development lifecycle very complex. In fact, without modern tools and processes, it would be almost impossible to meet today's delivery times and budget requirements. Because of this, several big organizations such as Raytheon, Northrop Grumman, Lockheed Martin, Boeing, and others—came together to evolve new methods for radar and EW systems development. Model-Based Engineering (MBE) is one such technique.

This chapter reviews the MBE technique. It also examines in detail how a set of simulation and modeling tools can work together to support MBE.

MBE Basics

As per the final report¹ of the MBE subcommittee of National Defense Industrial Association (NDIA), MBE is defined as:

“An approach to engineering that uses models as an integral part of the technical baseline that includes the requirements, analysis, design, implementation, and verification of a capability, and/or a product throughout the acquisition cycle.”

During development, therefore, all aspects of radar acquisition have to be considered. MBE was originally derived because of several gaps in the practice and the process of developing complex systems. While the negatives may have necessitated MBE, the advantages have accelerated the focus and attention on it. MBE's main advantages include the ability to:

- quickly evaluate what's not possible by exploring the entire project scope
- derive all downstream activities
- come up with quick proposals and Rough Order of Magnitude (ROM) estimates
- rapidly evaluate the system performance for changing requirements
- use the top-level model as the beacon for every subsystem development

With a system model, it's possible to derive all subsystems' requirements and partition the design margins more meaningfully; a process generally known as top-down design. In the case of MBE, the system model not only guides the subsystem design, but also helps define the system test, manufacturability and cost of production, among other things. This also leads to the ability to generate a quick proposal that is totally devoid of impossibilities and has a decent probability of success.

What are the impossibilities in the context of radar? Certainly, radar cannot have infinite range and a pulse radar requires a minimum range dictated by the finite speed-of-light. A pulse Doppler radar does not receive while transmitting. Hence, any signal that returns during transmission is not detected. This limits the detection range and this limitation comes from the physics of the system. Similarly, we can identify other limitations associated with such things as resolution and Doppler ambiguity. With a good master model upfront, one can quickly examine these limitations early in the design phase.

Clearly the first, and perhaps the only, critical step in MBE is the development of the model. When developing the 'model' we need to consider two aspects:

- Width and versatility. How wide should the model be? The radar model must predict the performance under a variety of conditions, such as frequency range, complex environments, waveforms, wide variety of threats, and various interferences. It is generally desirable to build a model as wide and versatile as possible so that one can explore all the above conditions.
- Depth. How deep should the model be? This is an engineering and business decision. There are tools that allow both the fidelity and accuracy of the building block models to be increased infinitely. Doing so; however, would increase the simulation time enormously and could be prohibitive and counterproductive from a business point of view. Hence, a good system model is one that has enough accuracy, but that also simulates quickly. A good system model also has fidelity that can be progressively increased on demand.

Let's now go to the question of: What is being engineered? In the context of radar, this can be several systems. We can view radar as a system of systems as shown in Figure 2.1.

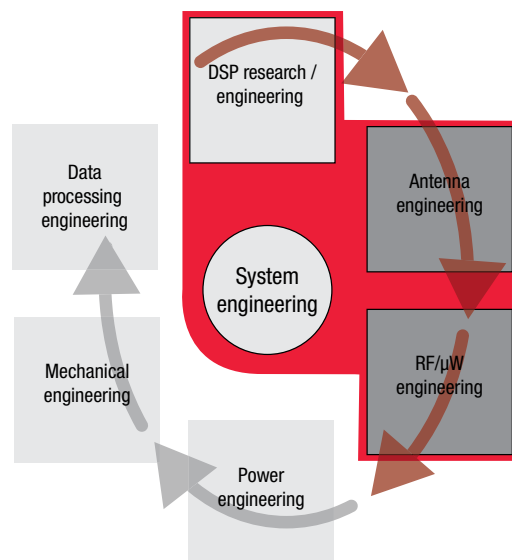

Figure 2.1. Radar can be viewed as a system of systems.

For the rest of the discussion we will consider only the electronic system of radar, which includes the DSP and RF/MW subsystems in the transmitter and receiver, and the antenna. However, the methodology applies to all other systems each requiring a set of special tools.

The MBE approach can be efficiently described by a V-diagram (Figure 2.2). The V-diagram is adopted by systems engineering and is available from various papers and text books. The specific one shown in Figure 2.2 is from the presentation at the INCOSE workshop².

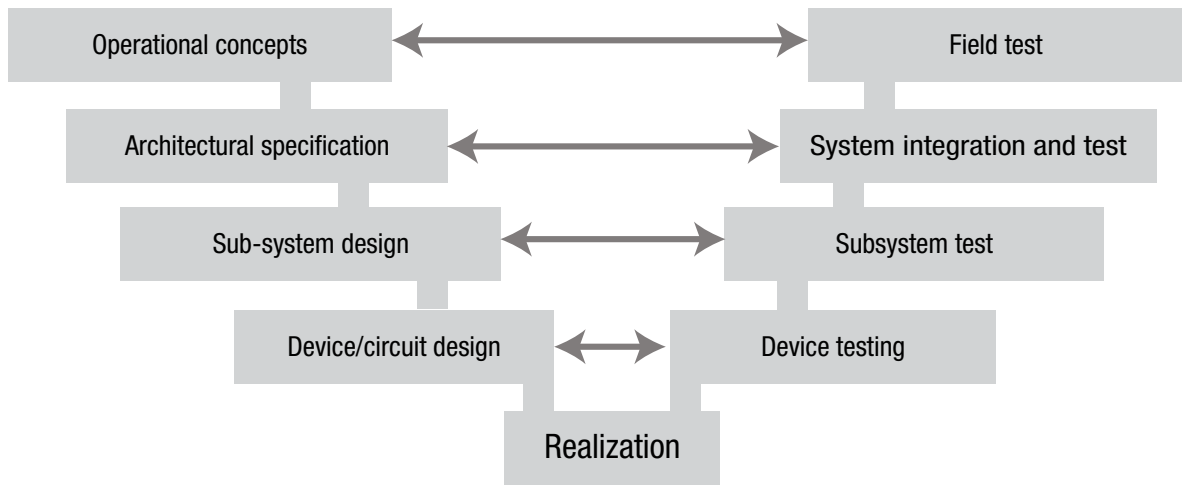

Figure 2.2. A V-diagram of an MBE approach.

Figure 2.2 shows both a top-down and bottom-up flow. The definition and decomposition flow dictates the specification of the subsystems and their margins. It is common that the subsystems themselves are complex and hence, they can also be described with individual V-diagrams as shown in Figure 2.3.

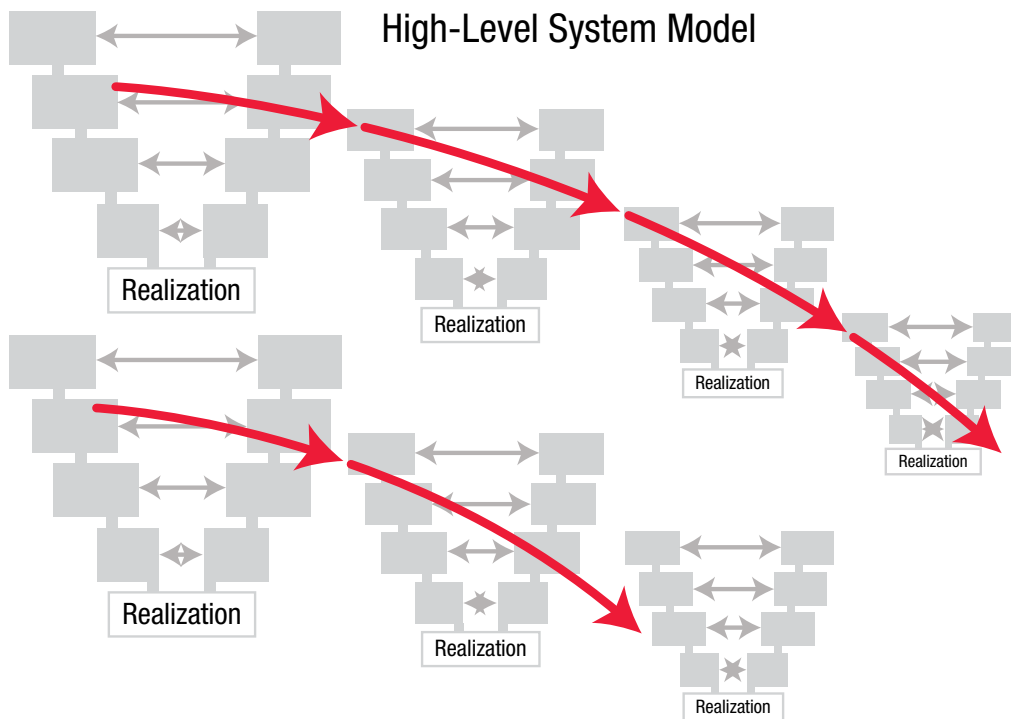

Figure 2.3. Individual V-diagrams of the individual subsystems in an electronic system.

Figure 2.3 implies that the subsystems themselves can be complex and as such need to be treated as individual systems that should also follow the MBE approach. For example, the phased-array subsystem in an antenna is very complex and needs to be treated with MBE. Similarly, the Transmit-Receive (TR) module, designed as an integrated circuit, may have to be treated like a system and all the system concepts should be applied.

Each of these subsystems must be designed using an appropriate tool. Let's call the V-diagram one level below a child-V, and the one above child-V, a mother-V. An important requirement of MBE is that a mother-V be able to call, command and control child-V. It should be able to simulate child-V, keep it in standby mode, examine the output from child-V, and change the inputs to child-V to continue with the simulation on demand.

The tools used to design each of these systems—which by itself is a subsystem for the higher-level system—are very likely different tools. For example, a system-level simulation is done using popular tools like Keysight's PathWave System Design (also known as SystemVue), while the subsystem (e.g., a TR module) is designed using a circuit simulator, for example with PathWave Advanced Design System (ADS). Depending on the situation, some of the subsystems could be actual hardware connected to measuring instruments. It quickly becomes clear that for maximum effectiveness, however, all these tools should be inter-operable. In other words, a higher-level system simulating tool should be able to call a subsystem simulating tool and put it in a command-and-control mode.

Once the above requirements are satisfied, one can build the system model to simulate the end-to-end performance of the system. Let's see how such a system model can be created for a radar using a set of tools.

On close observation of the V-diagram in Figure 2.2, notice that the left side of the V pertains to top-down design, while the right pertains to integration and verification. Verification is usually done with actual hardware, meaning that it is not performed until the actual hardware is available. With modern tools, a top-level model can be built that allows verification to be done in simulation. To highlight the difficulty, imagine having to co-simulate RF and DSP circuits. However, very few tools in the industry support this kind of co-simulation. With an improved co-simulation capability though, both sides of the V-diagram (top-down design and bottom-up verification) can be done entirely in simulation. Final verification is then done with actual hardware. Performing the entire V in simulation eliminates major risk factors early in the development cycle.

Building a System Model Using SystemVue, MATLAB, and STK

To better understand how to build a high-level system model, consider the example of a mono-static pulse Doppler radar, including the radar platform and target. We will show that this model can be easily expanded to bi-static and multi-static radar systems, as well as multiple targets. We will also show how clutter, jammer, interferer, and noise can be added to the target return. The radar and the environment being built will cater to a typical operational scenario depicted in Figure 2.4.

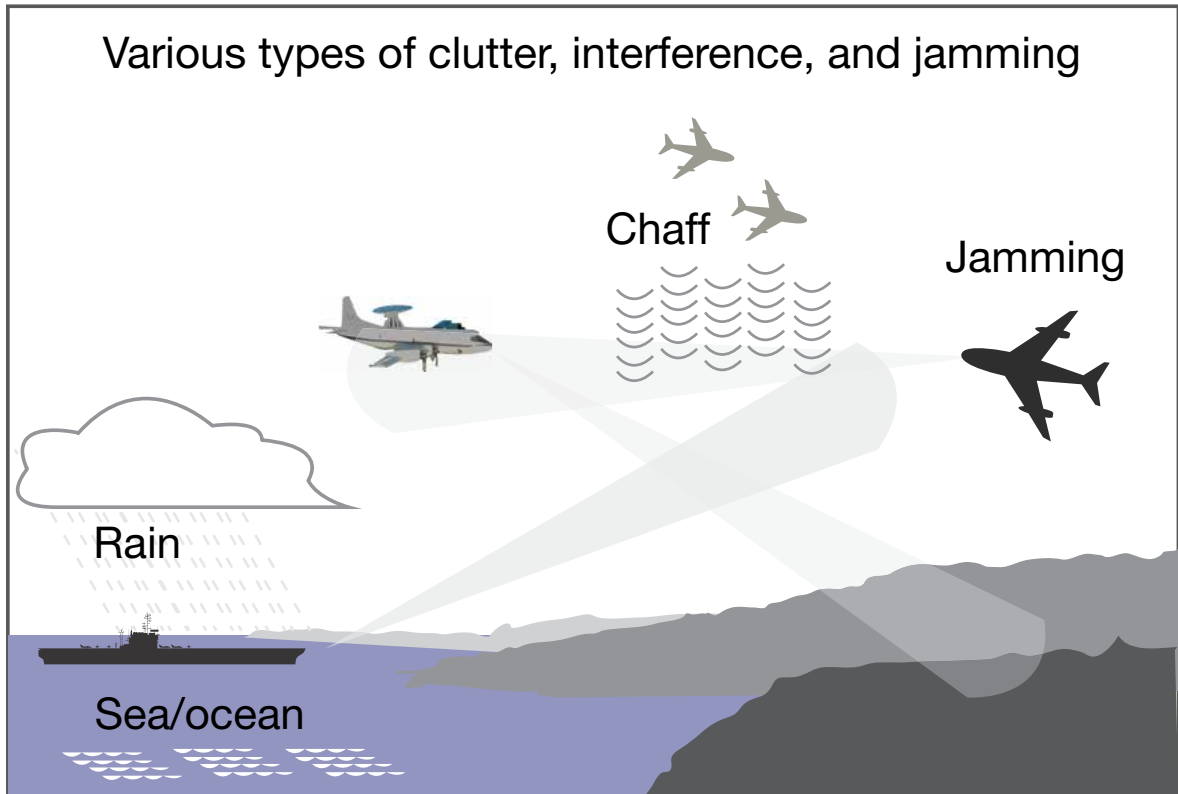

Figure 2.4. This image depicts the typical operation of a mono-static pulse Doppler radar.

From Figure 2.4, it's apparent that the radar is on a moving platform, a ship, and that there are three targets, one jammer and the clutter caused by sea, rain and chaff. The communication signals from the city environment may act as interferers. Also, the radar could be treated as bi-static with the radar receiver on the reconnaissance aircraft. It is important to note that pictures like that shown in Figure 2.4 have to be made visible throughout the organization engaged in MBE. Everyone then will be able to check the performance of their individual subsystems through the system model.

Target return, jamming, clutter and noise: The scheme for modeling the target reflection, jamming signal, clutter, and noise is shown in Figure 2.5.

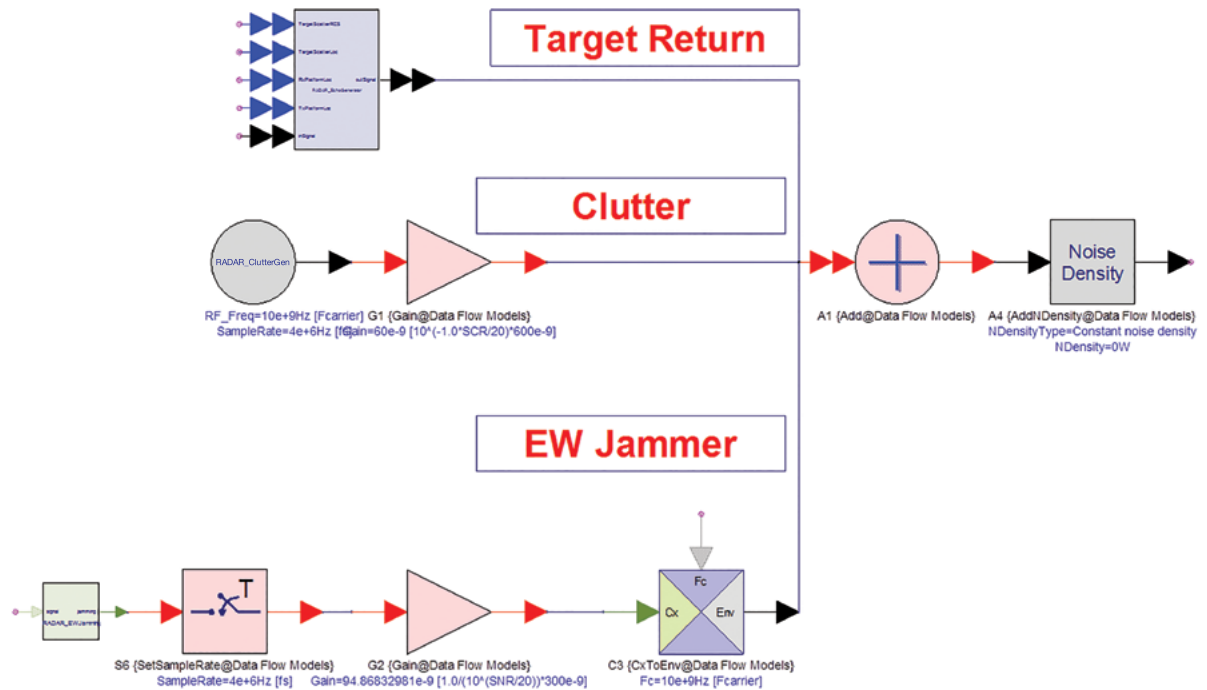

Figure 2.5. Shown here is the scheme for modeling the target reflection, jamming signal, clutter, and noise.

The inputs to the target return model—the target position, target RCS, transmitting antenna position, receiving antenna position, and waveform from the source—come from the antenna layer. The output from this model is computed using the radar equation.

The Jammer model is versatile and allows both cover and deceptive jamming to be modelled. There are four types of cover jamming: barrage, spot, multi-spot, and swept spot. For barrage jamming, the model generates the Additive White Gaussian Noise (AWGN) with mean and standard deviation values determined by the parameters Mean and Stdev in the full bandwidth. For spot jamming, the model generates the band limited AWGN noise. The normalized bandwidth is determined by the parameter Bandwidth. Also, the FilterTapsLength is used to set up the maximum length of low-pass filter. For multi-spot jamming, the model generates band limited AWGN noise in the sub-bands determined by the parameter MultiSpotBand, which can be used to set up the normalized start and cut-off frequencies of the passbands. For swept-spot jamming, the band-limited AWGN noise sweeps in the scope of the full band, with the sweep rate decided by the parameter SweepFreqStep.

The clutter model is built from the probability of distribution (PDF) and power spectral density (PSD) functions. It is designed to generate the correlated coherent and non-coherent clutter. The model, which supports Gaussian, LogNormal, Weibull, and K clutter amplitude distribution, is a computationally intensive model. When used in the workspace, it causes the simulation speed to slow.

The clutter model is different from noise in two major ways. First, the power spectrum of clutter is not white and is the result of echo. Second, the model supports the Gaussian, all-pole and Cauchy power spectrum model.

NOTE. The idea here is not to absorb all of the details of the model, but to emphasize that in MBE the models have to be made as wide as possible.

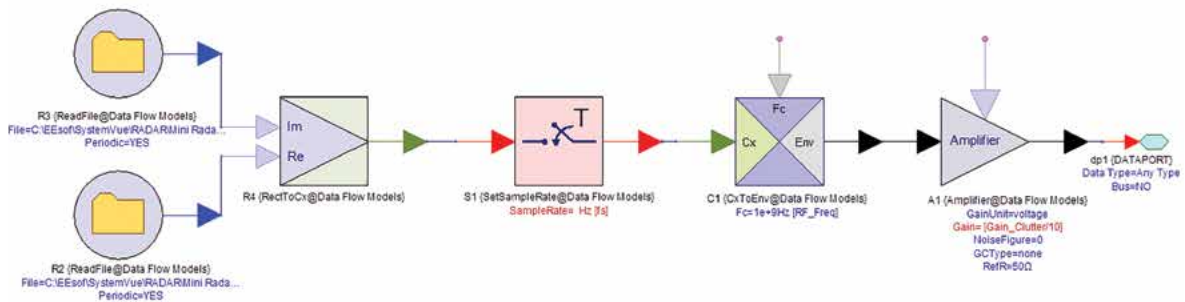

Figure 2.6. Measured or simulated clutter files can be used for a given terrain.

The measured clutter files, in terms of I and Q, are read from the external files into the simulation.

After the addition of noise, the return signal goes into the radar receiving antenna. The receiving antenna is very similar to the transmitting antenna in that it takes input from the antenna layer and forms a beam in the direction of the target. The output of the receiving antenna is passed through an RF down-converter into the baseband processor. Adaptive digital beamforming techniques are used to combine the outputs of various phased-array antenna elements to form a signal input for the pulse compression block.

NOTE. While the model is versatile, it can take a long time to simulate and this is contrary to the MBE system model philosophy. Hence, a better way is to use measured or simulated clutter files for the given terrain. One such implementation is shown in Figure 2.6.

Increasing Subsystem Model Fidelity

While the system model is useful for the quick top-level simulation, it should also support verification of the subsystems designed with higher fidelity models. As an example, the power amplifier (PA) in the transmitter might be designed by a circuit specialist and it may be desirable to see how the actual PA circuit performs in the top-level model (Figure 2.7).

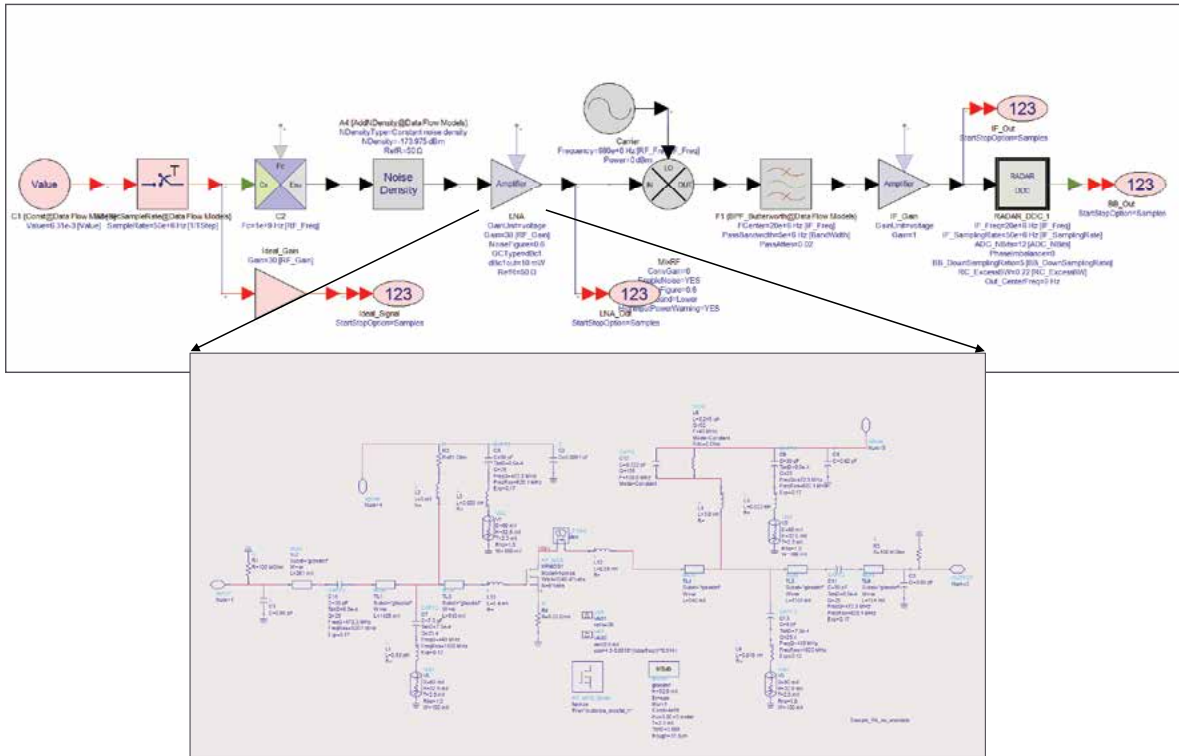

Figure 2.7. To see how the actual LNA circuit in the receiver performs, ADS can be used to simulate it. SystemVue enables co-simulation with ADS.

A circuit simulator like PathWave Advanced Design System (ADS) can simulate actual circuits in the design. SystemVue can co-simulate with ADS. It is also possible to scale the fidelity of the circuit model. To do this, we extract the X-parameters* of the circuit and place it as a model for the amplifier in the system simulator.

An example can also be provided for baseband models. We simply substitute HDL code for a building block that considers the finite precision accounting for the quantization effects. Another example is to read in the measured antenna patterns for the antenna elements rather than assuming an analytical antenna factor. The choice of varying fidelity for the building block models is a key requirement of MBE.

* "X-parameters" is a registered trademark of Keysight Technologies. The X-parameter format and underlying equations are open and documented. For more information [click here](https://www.keysight.com/in/en/lib/resources/miscellaneous/x-parameters-open-documentation-trademark-usage-and-partnerships.html). (https://www.keysight.com/in/en/lib/resources/miscellaneous/x-parameters-open-documentation-trademark-usage-and-partnerships.html)

Bringing a More Dynamic Environment into the System Model

The software platform can also co-simulate with the STK simulation tool from Analytic Graphic Incorporated (AGI), an Ansys company. STK is a physics-based software geometry engine that accurately displays and analyzes land, sea, air, and space assets in real or simulated time.

First, users model the time-dynamic position and orientation of vehicles. Given these dynamic positions and orientations, users can model the characteristics and pointing of sensors, communications and other payloads aboard the asset. STK then determines the spatial relationships (e.g., line-of-sight) between the assets of interest and all the objects under consideration. These relationships can also be modeled across multi-hop links or over regions of interest. STK assesses the quality of these relationships through a wide array of constraining conditions (e.g., payload capability, unique user algorithms, etc.), while also incorporating environmental effects such as terrain, lighting and weather conditions on sensor visibility or communication link quality.

When SystemVue is co-simulating with STK, the inputs are brought from STK directly into SystemVue's signal layer. For more details on this process, please refer to reference 3.

Any tool utilized to build a system using the model-based engineering technique requires three key characteristics. It must be able to create the wide and versatile models needed to build a system model. It must support scalable fidelity for the models. And, it must have the ability for an external program to command and control the system model.

References

1. Final report of the Model Based Engineering (MBE) subcommittee, NDIA systems engineering division, M&S committee, February 10, 2011.
2. Ron Williams, INCOSE Model Based Systems Engineering, Integration and verification scenario, Raytheon, INCOSE IW12 MBSE Workshop, January 21-22, 2012.
3. Virtual flight testing using SystemVue and STK, 5991-1254EN, Keysight Technologies.



<https://www.keysight.com/see/radar-ew-system-design>

Chapter 3

Radar and EW System Design and Interference Analysis

This chapter outlines an example of PathWave System Design (SystemVue) software for performing radar and EW system design and jammer/interferer analysis. Some of the key areas to be discussed include how to implement a radar chirp waveform, design an RF chain for the transmitter and receiver, and perform pulse-compression analysis using fast Fourier transform (FFT) based convolution. Finally, the radar system is tested in the presence of unwanted interference and jamming signals to study the impact of such unwanted impairments on radar performance.



Custom Signal Generation

LFM chirp for radar system design

SystemVue offers a flexible platform to create custom signals. In the example shown in Figure 3.1, SystemVue floating-point Data Flow components were used to model the linear frequency modulation (LFM) chirp source. The integrator on the left increments time until the value for the pulse period is achieved, causing it to reset and start over. The values for u (μ) and w_c (ω_c) are computed as shown in Figure 3.1.

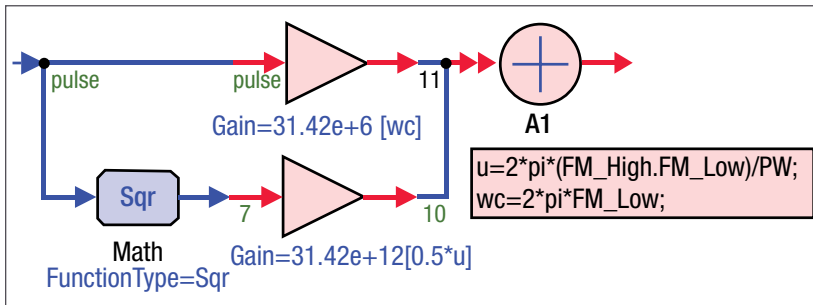

(3.1a)

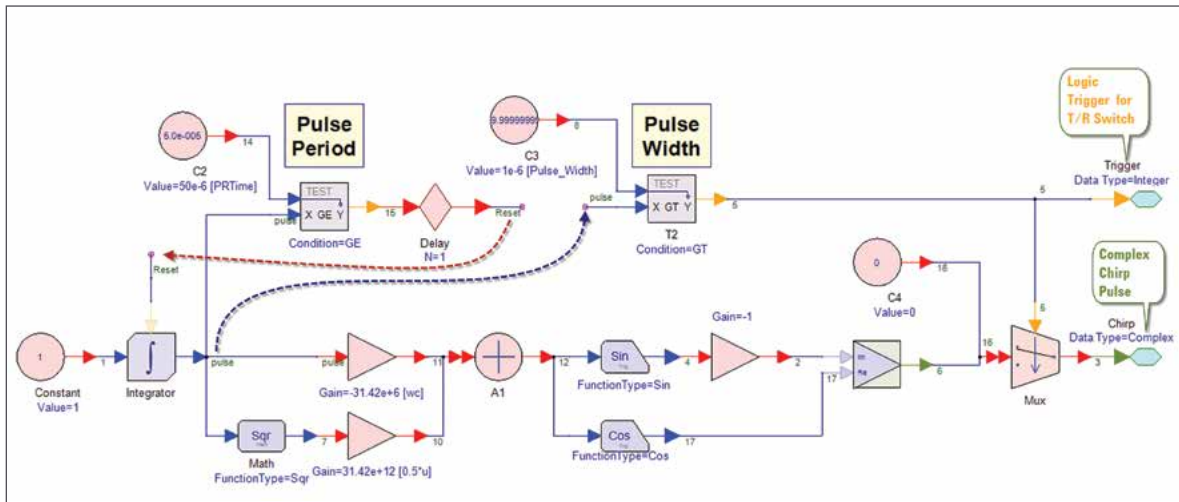

(3.1b)

Figure 3.1. Custom signal generation using SystemVue DSP library blocks

Custom signal generation using MATLAB script

SystemVue offers built-in MATLAB script language to be used throughout the program. In Figure 3.2, the LFM chirp source is defined in a MATLAB_Script component.

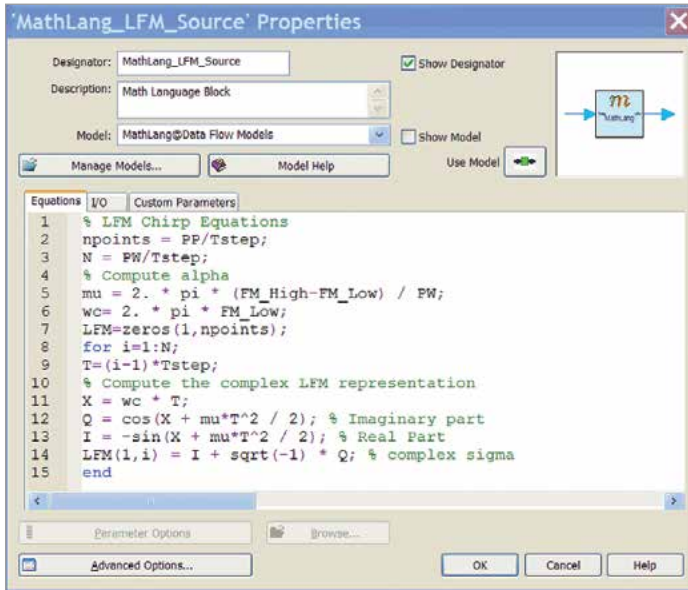
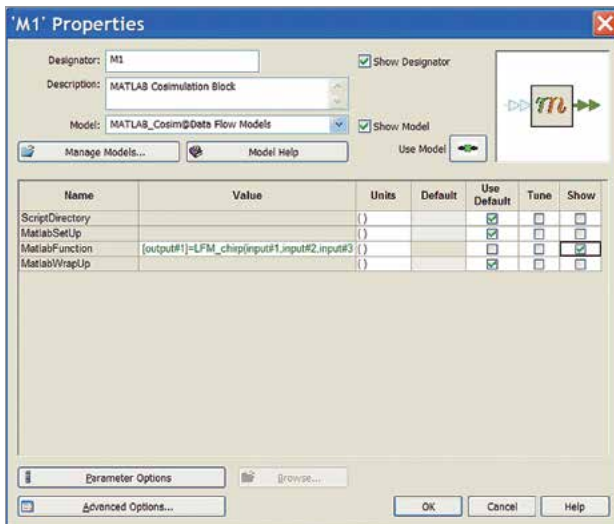

Figure 3.2. Custom signal generation using MATH Language in SystemVue

Custom signal generation using third-party tools

SystemVue offers direct links with C++, HDL, and MATLAB. Any custom signals written using these languages can be easily brought into SystemVue as shown in Figures 3.3 and 3.4. Co-simulation with MATLAB allows the user to incorporate pre-existing m-code files.



(3.3a. MATLAB co-simulation link

Figure 3.3. Linking MATLAB script with SystemVue

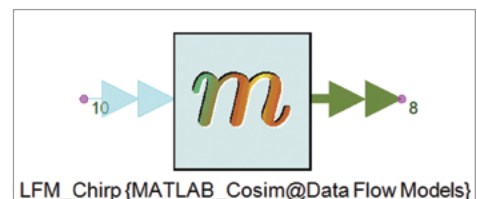

(3.3b)

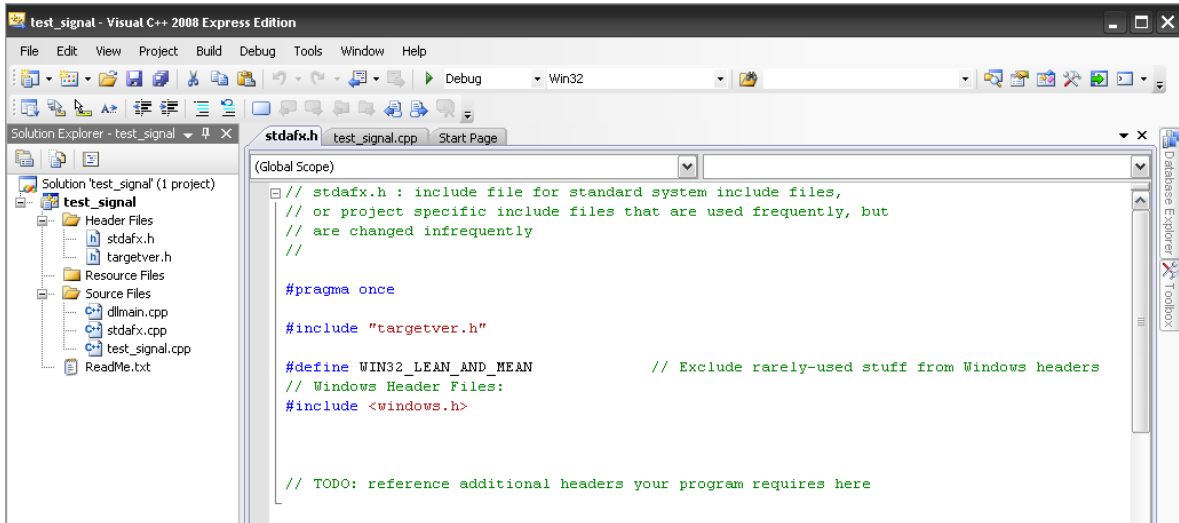

Figure 3.4. Custom waveform code in C++

LFM Chirp IF Generation

In this chapter, Math Language is used to generate the LFM waveforms used for the radar system design (Figure 3.5).

Note that the M-Code component does not provide SystemVue with the sample rate information that its built-in models do. It is recommended, therefore, that a sample rate component be added after a M-Code component that is used as a source to implicitly define the sample rate (Figure 3.5). The CxToEnvelope component defines the complex waveform as an RF Envelope waveform where I&Q, plus time and carrier frequency are defined. The spectral result, centered around 500 MHz, is shown in Figure 3.5.

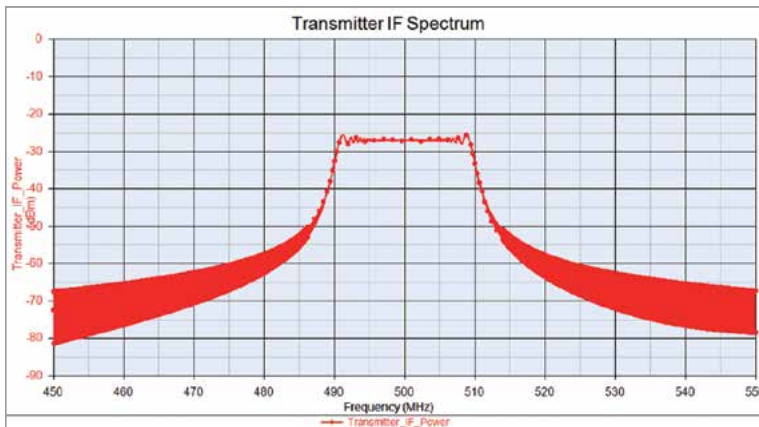

Figure 3.5a Transmitter IF Spectrum, centered around 500MHz

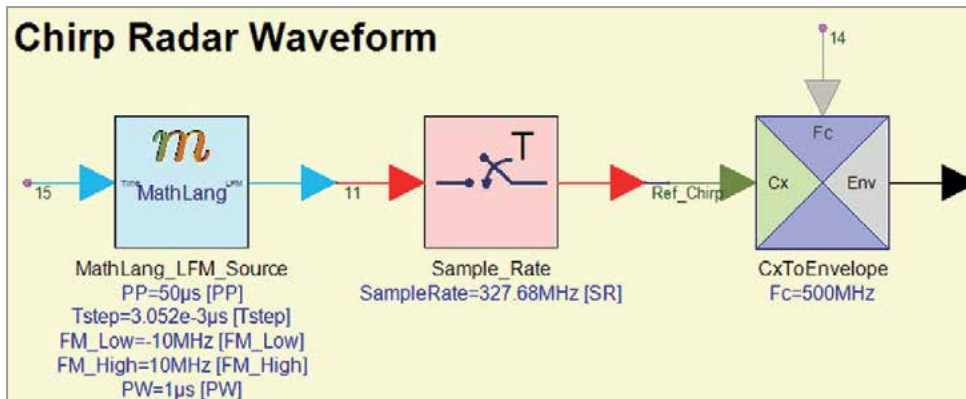

Figure 3.5b

Figure 3.5. LFM chirp signal generation and IF spectrum. Note that the Sample_Rate component declares the time-step for the un-timed complex numeric data emerging from the MATLAB Script source.

Transmitter RF Design

The RF chain of the radar transmitter was designed using the Data Flow RF block library in SystemVue, which offers users a variety of RF models to implement the RF section of the system (Figures 3.6a and 3.6b). Real-world impairments such as nonlinearities, LO phase noise, and mixer leakage products can also be incorporated into the simulation.

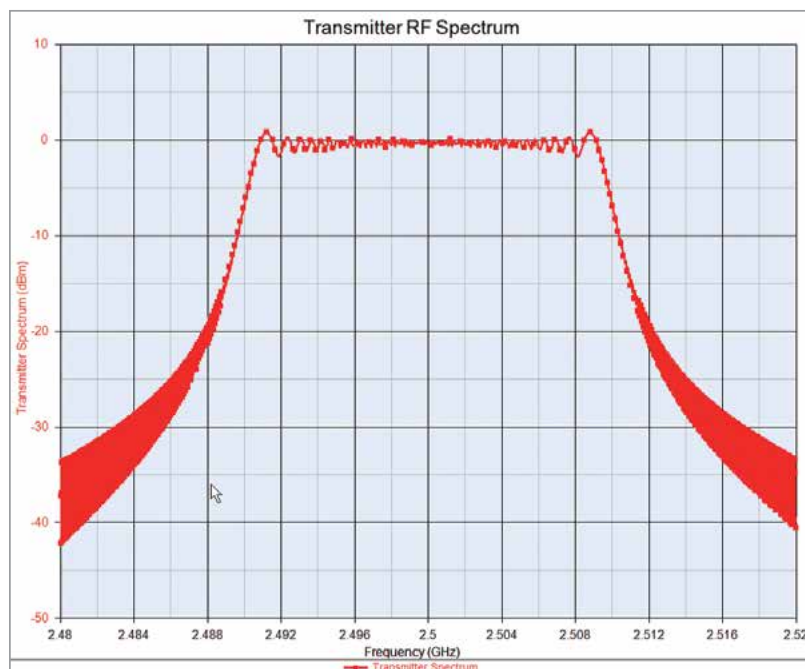

Figure 3.6a. Transmitter RF spectrum

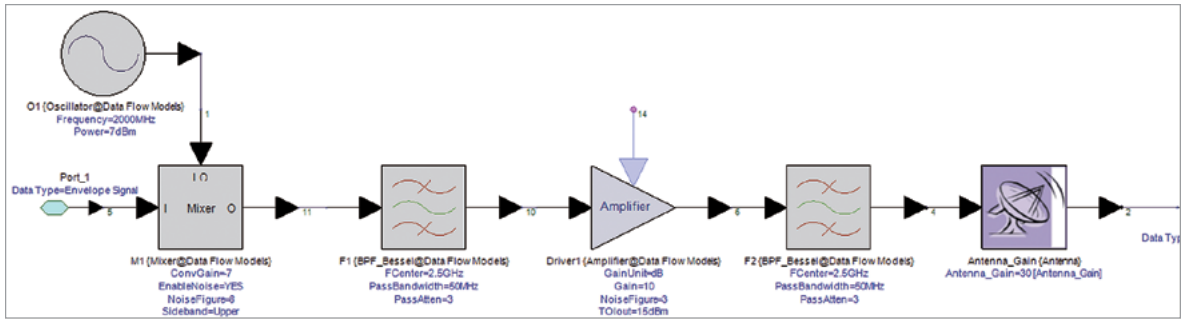

Figure 3.6b. RF section of radar transmitter using the RF block library in SystemVue

Radar Propagation Loss Modeling

The radar propagation path modeling was performed using SystemVue library blocks to implement standard math equations for propagation delay and free-space propagation loss (Figure 3.7a and 3.7b).

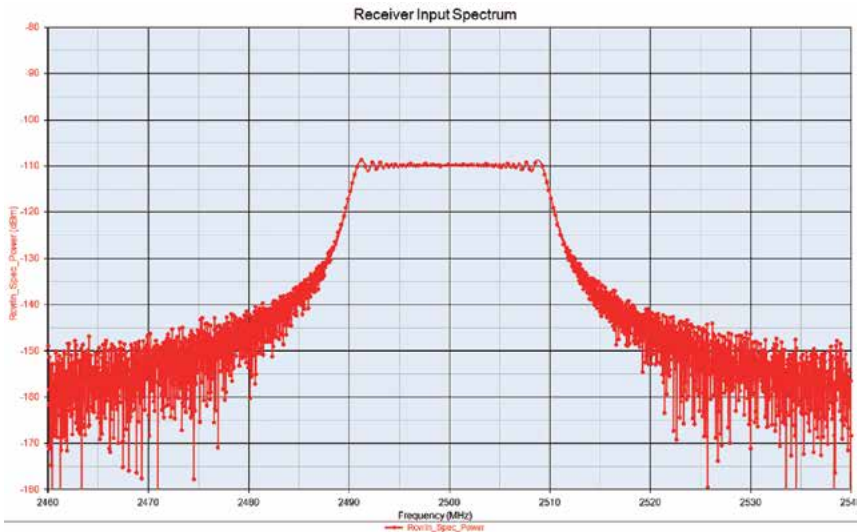

Figure 3.7a. Radar signal as seen at receiver input

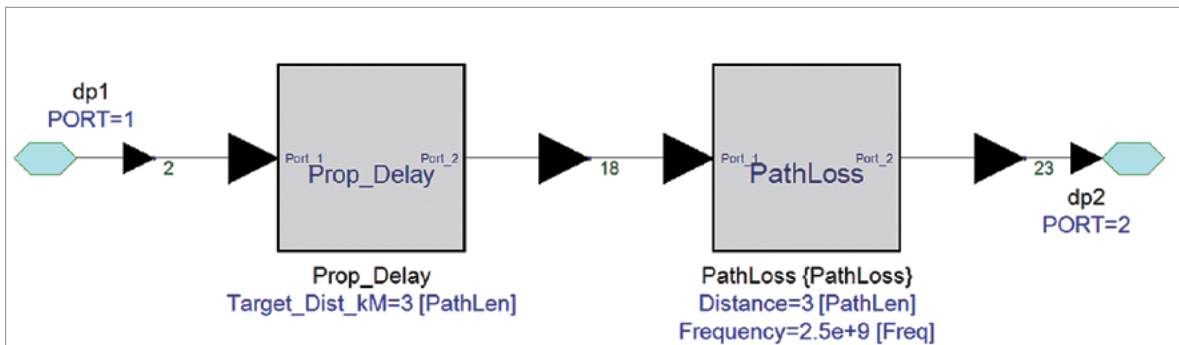

Figure 3.7b. Implementing radar propagation loss and propagation delay models

Radar Receiver Design

The radar front-end (FE) receiver was designed using RF blocks. Various budget analyses were performed to optimize the performance as shown in Figure 3.8a to Figure 3.8e.

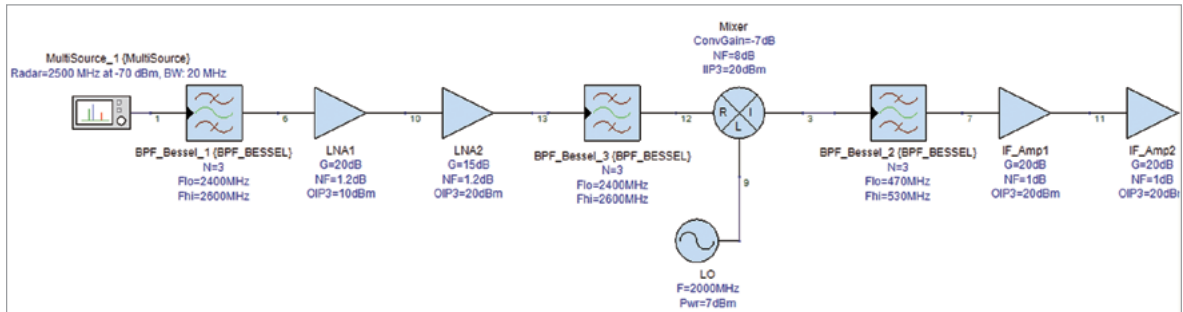

Figure 3.8a. Radar front-end receiver design using RF block library in SystemVue



Figure 3.8b. Noise-figure budget analysis of receiver front end

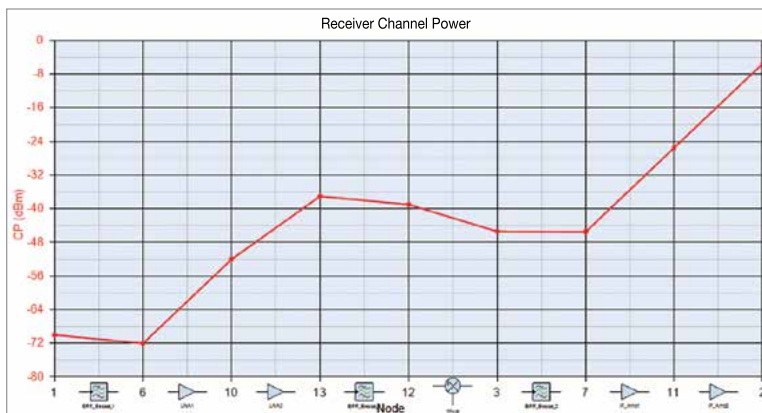

Figure 3.8c. Channel-power budget of receiver front end

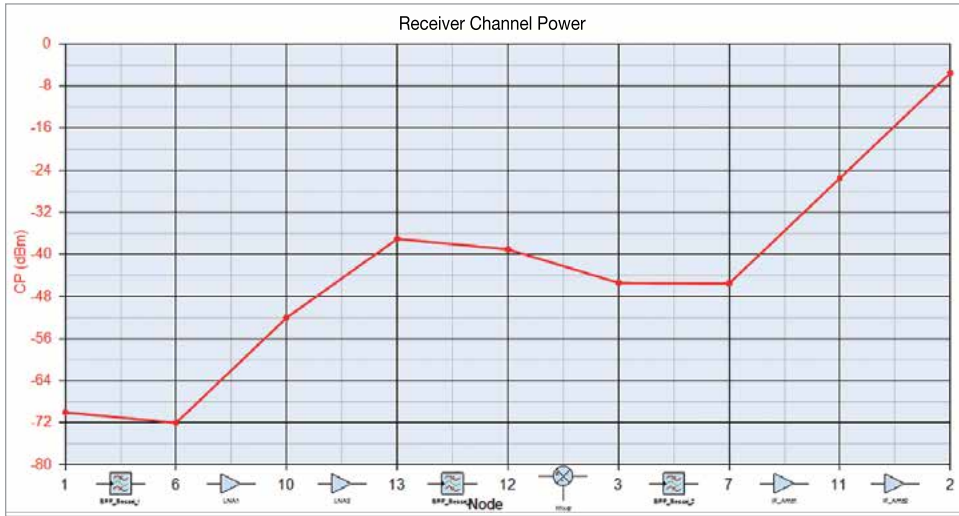

Figure 3.8d. Cascaded-gain budget of receiver front end

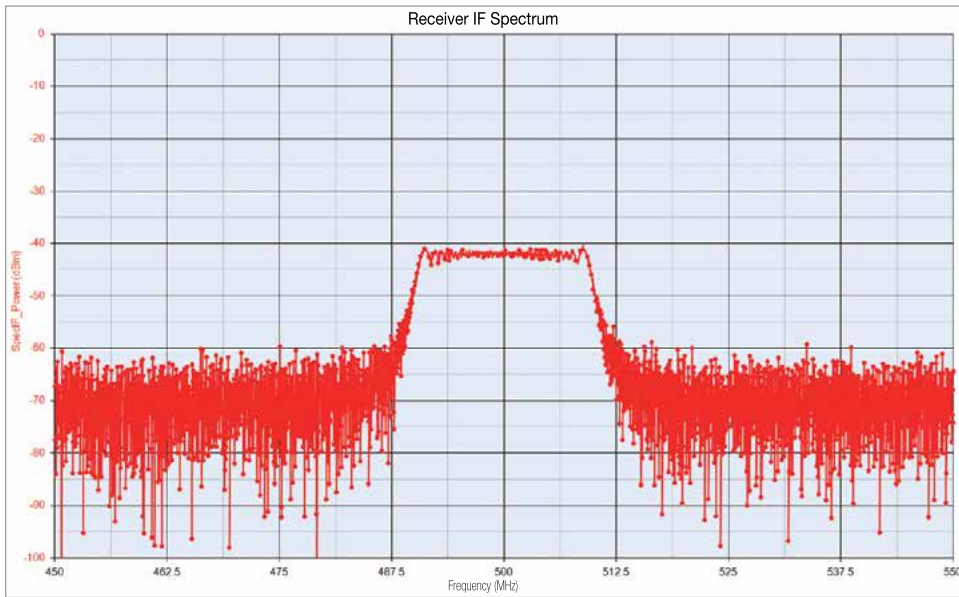

Figure 3.8e. Receiver output IF Spectrum

Receiver Signal Processing

The receiver IF was filtered, down converted, and down sampled for analog-to-digital conversion. The post processing algorithm was designed using SystemVue DSP library blocks as shown in Figure 3.9a to Figure 3.9e.

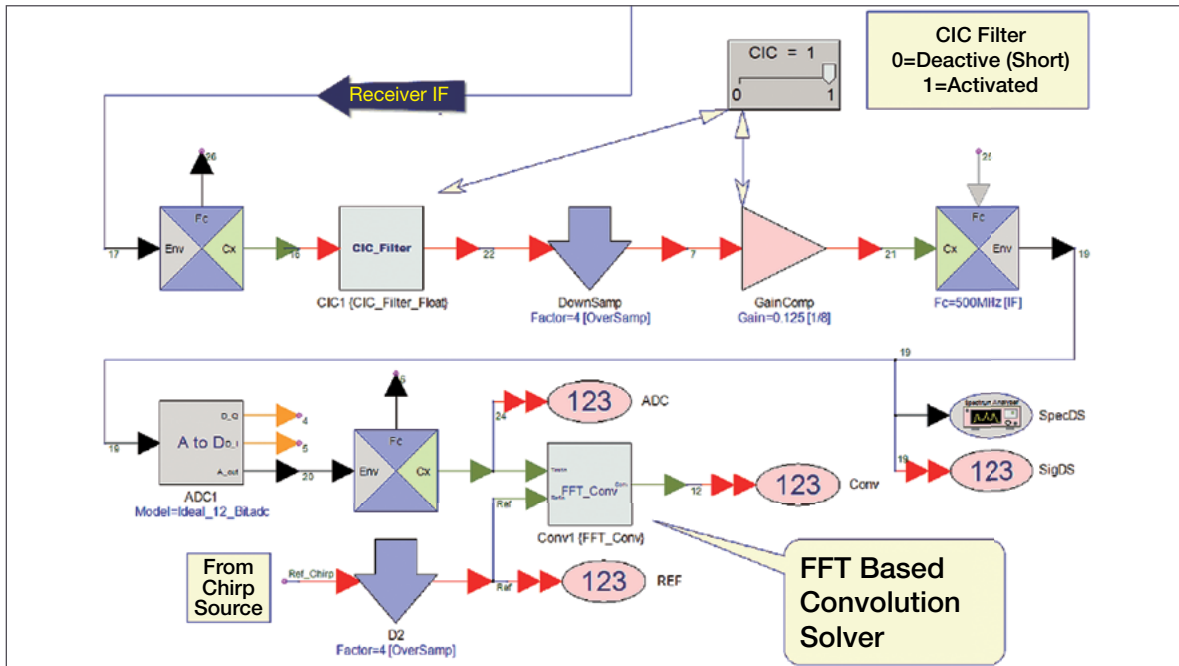

Figure 3.9a. Top-level view of receiver IF post processing

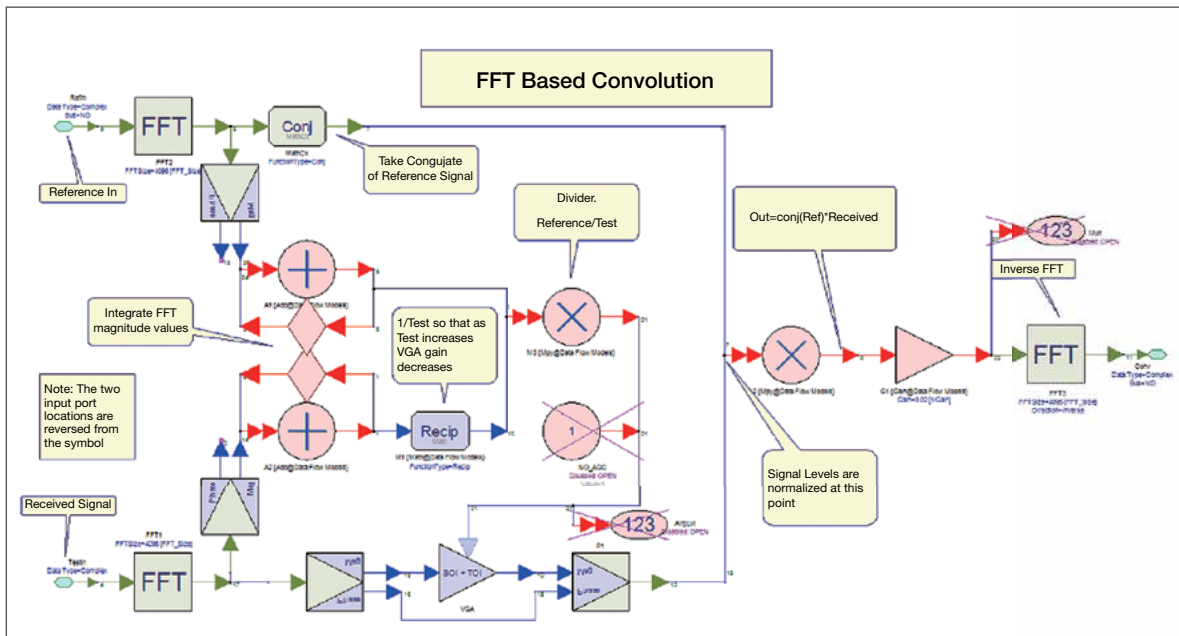

Figure 3.9b. FFT-based convolution algorithm (pulse compression) using SystemVue DSP library blocks

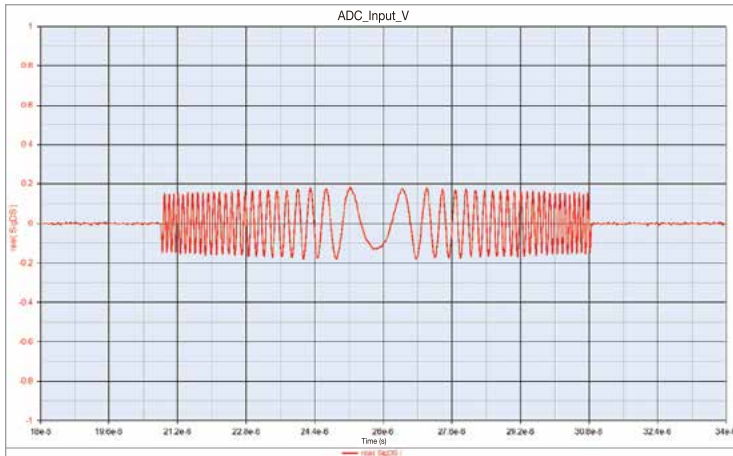

Figure 3.9c. Time-domain waveform at ADC input

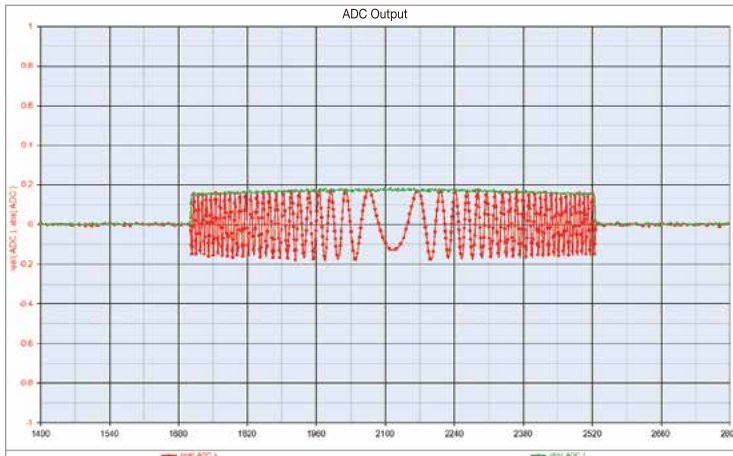

Figure 3.9d. Time-domain reconstructed data at ADC output

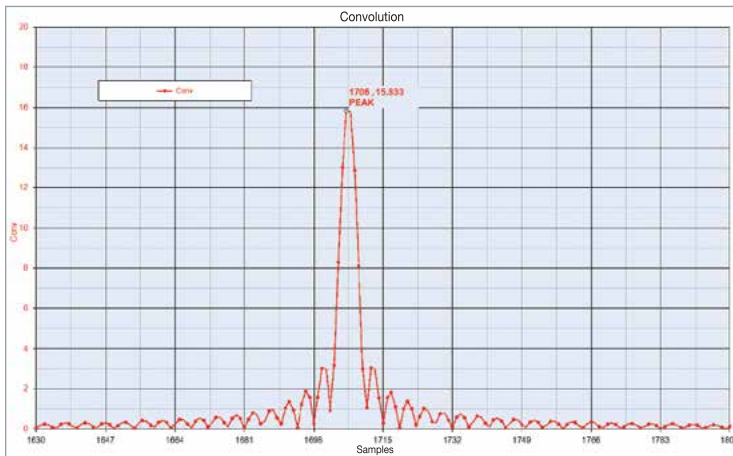

Figure 3.9e. Compressed pulse after post processing

Jammer/Interference Analysis

Jammer/interference analysis can be performed on the radar system design as shown in Figure 3.10a to Figure 3.10d. Note that jammers/interferers can be varied to have the different levels of amplitude and frequency needed to perform radar receiver fidelity analysis and what-if analysis.

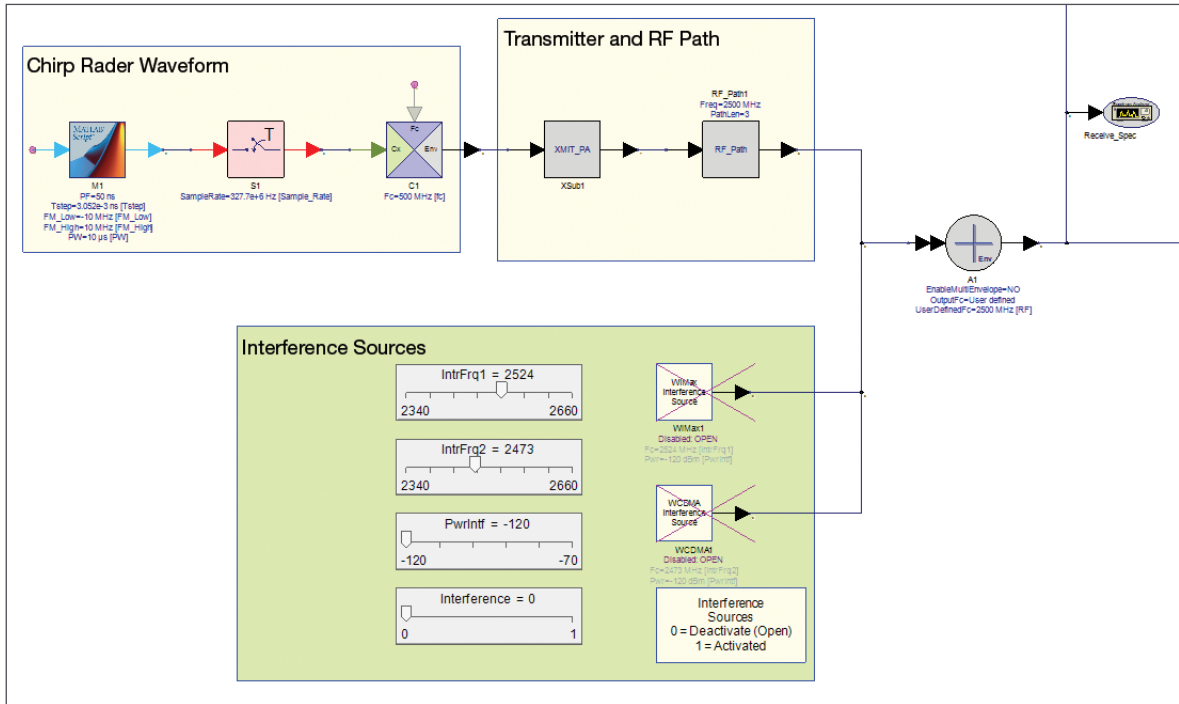

Figure 3.10a. Creating and combining interferer source with radar waveform

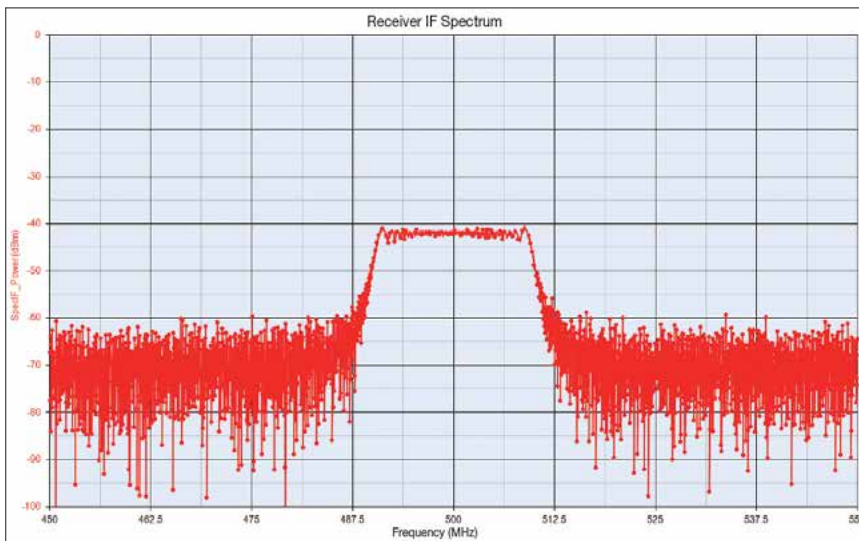

Figure 3.10b. Composite spectrum at radar receiver input

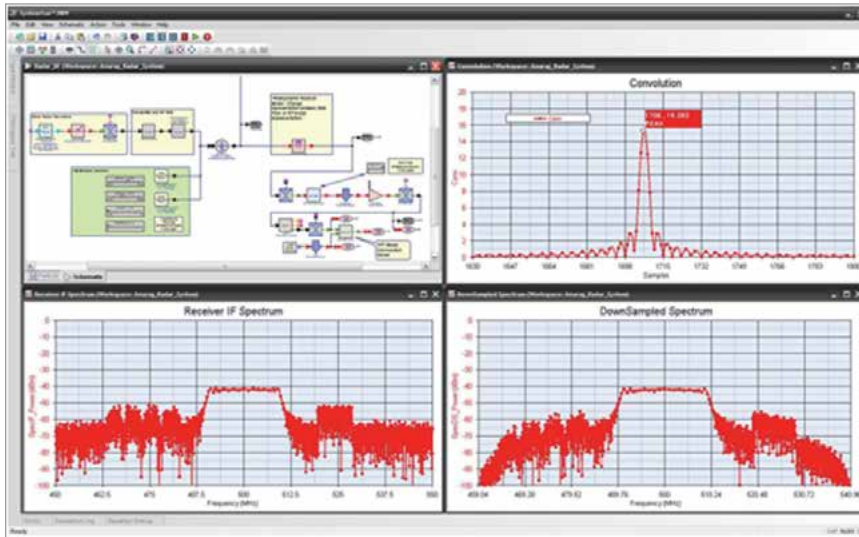

Figure 3.10c. Various waveforms in the presence of jammers/interferers

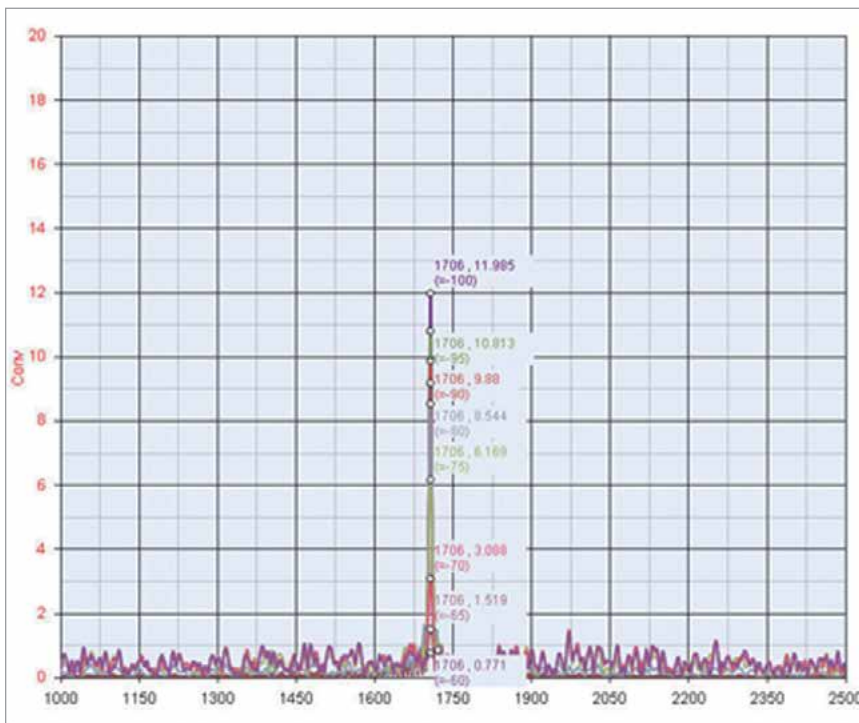

Figure 3.10d. Sweeping interference power to see its effect on compressed-pulse peak detection

Integrating Software and Instruments for Advanced System-Level Design

While it is always possible to design and test complex defense systems separately, ideally the engineer would like these two domains to be interlinked to enable a fully integrated approach to system development and testing. This can be accomplished using the native instruments link option in SystemVue. This option allows both the designer and test engineer to link a variety of test and measurement equipment with SystemVue to achieve the following objectives:

- Create and download arbitrary signal to instruments
- Create near real-life signals for system integration testing in the lab environment
- Capture signals from instruments and design remaining blocks by taking real device distortions into account

Integrated test setup

A fully integrated approach to system development and testing can be used to address the case study presented in this chapter. The test setup, as shown in Figure 3.11a, requires:

- SystemVue software installed on a PC
- A Keysight vector signal generator (VSG), in this case, the N5182A MXG
- A Keysight PXA Signal Analyzer, in this case, the N9030A PXA

In this case study, the LFM chirp radar waveform is used. It is designed using SystemVue software with different specifications and downloaded onto the VSG (Figures 3.11b and 3.11c). SystemVue allows data to be downloaded from any node in the design. In this case, the node selected is the one where there is a combined spectrum of main radar return coming to the receiver input and where interfering signals can be added to perform receiver signal processing fidelity test (Figure 3.11d).

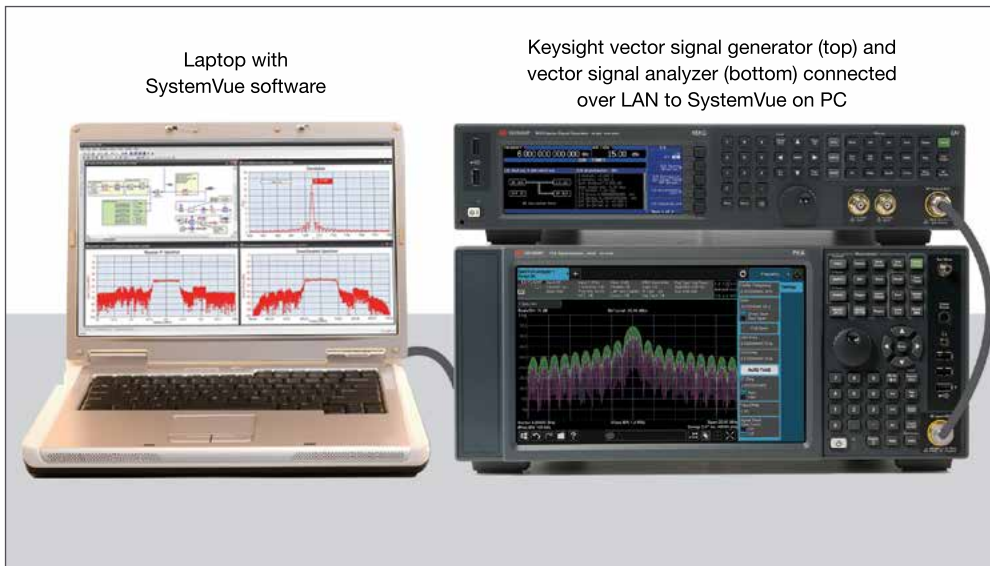

Figure 3.11a. Custom signal download to a VSG

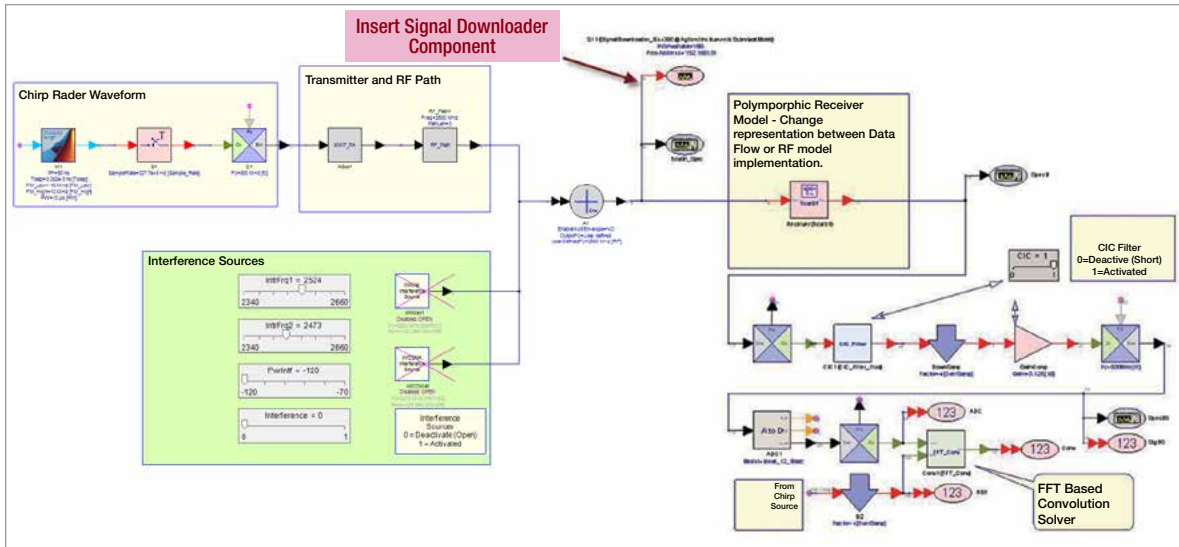

Figure 3.11b. SystemVue workspace with signal downloader component to download custom waveform to VSG

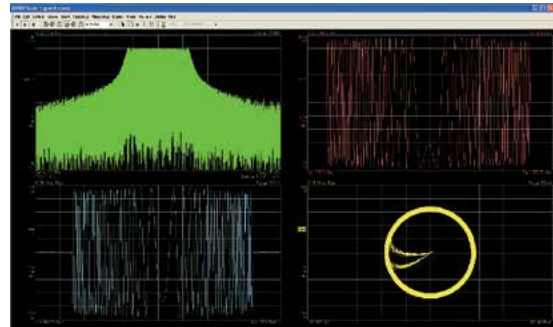
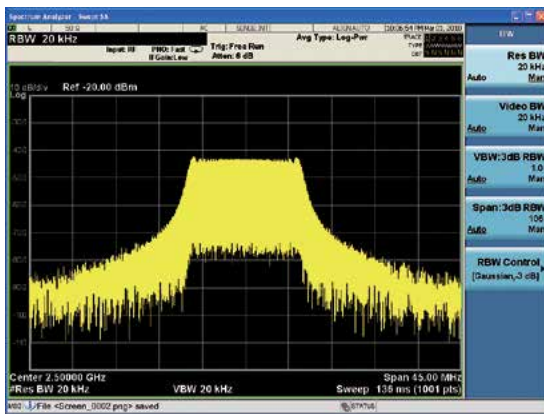

Figure 3.11c. Ideal LFM chirp waveform being analyzed using spectrum analyzer and its vector signal analysis using 89600 VSA software running on the N9030A PXA

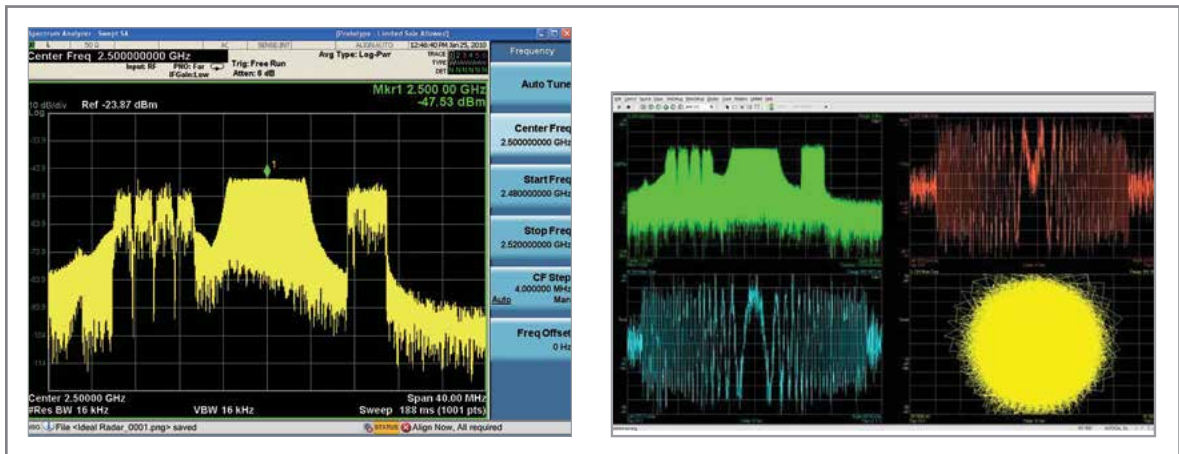
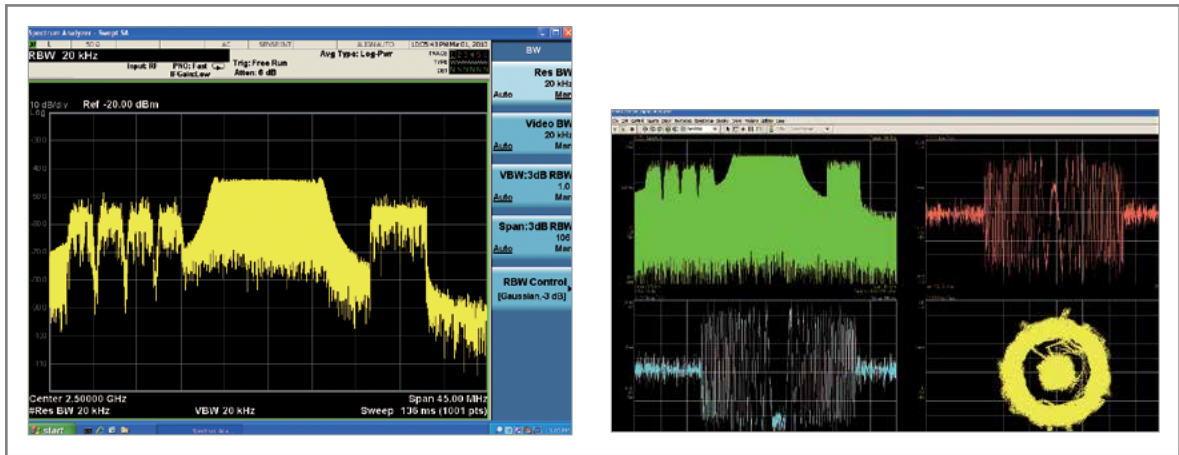
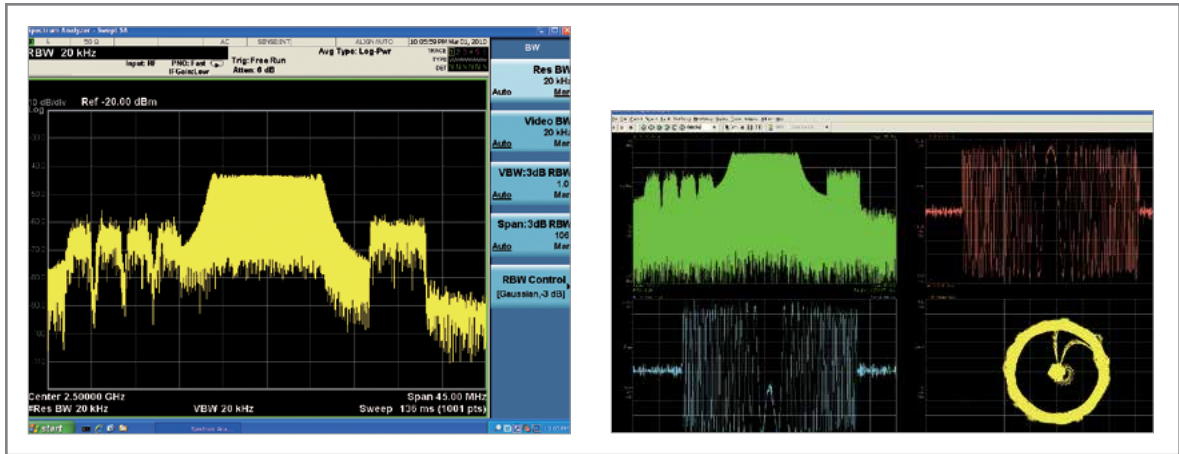

Figure 3.11d. Composite LFM radar with interferer signal and interference power sweep to understand receiver behavior under different conditions



Chapter 4

Simulation and Verification of Pulse Doppler Radar Systems

Modern radar systems that operate in environments with strong clutter, noise, and jamming require advanced digital signal processing techniques. Direct analysis techniques often fail when designing such complex systems. Although simulation is often used, most simulation tools do not have enough models and integration capability to handle modern radar systems.

This section proposes a solution to this dilemma, a system-design methodology that uses PathWave System Design (SystemVue). Examples will be used to illustrate how advanced pulse Doppler (PD) surveillance radar with moving target detection (MTD) and a constant false alarm rate (CFAR) processor can be designed. To ensure the design works properly, the platform can be connected to instrumentation for system test and verification. This allows users to reduce their system development time and cost, while also decreasing their chances of unexpected system failures late in the system development process.

System Design Challenges

Advanced radar systems are very complex, necessitating sophisticated signal processing algorithms. Effective algorithm creation requires both a platform for simulation and verification. Models for signal generation, transmission, antennas, T/R switching, clutter, noise, jamming, receiving, signal processing, and measurements are also needed to create advanced algorithms. Most simulation tools do not have enough models and the integration capability needed to design such complex algorithms.

Signal Processing Algorithm Creation

The system-design methodology proposed below uses SystemVue. It concentrates on algorithm design for PD systems. The development of MTD and CFAR processors in a time-efficient manner are used as examples to better understand this methodology.

To begin, consider the tasks undertaken by the radar DSP algorithm designer, which typically breaks down into the following two stages:

Stage 1. Design the algorithm in software and verify it using a simulation tool.

To accomplish this task, the designer needs:

- A user-friendly algorithm modeling environment to easily create and debug the algorithm during development. The environment should support multiple languages, such as m-code, C++, and HDL.
- Signal sources and measurements to verify the algorithm during verification, once it is created. Unfortunately, it is not a simple task for the DSP algorithm designer to create radar signal sources with radar cross section (RCS), clutters, noise, and jamming. The designer might also encounter difficulty creating measurements for the algorithm. Consequently, a tool that provides radar sources and measurements is desired.

Stage 2. Implement and test the algorithm in hardware.

After the algorithm testing and verification are finished, it needs to be implemented in hardware. To accomplish this task, a hardware test platform must be created.

To address these needs when creating the MTD and CFAR processor, a platform that provides the following functionality is required:

- An interface to a vector signal generator to generate test signals. The vector signal generator provides radar signal-generation test sources and models for RCS parameters, Clutter, Jamming, Doppler, and Frequency offset.
- An interface to a vector signal analyzer to verify the implemented hardware as compared to the original algorithm. The platform must support a wide range of measurements including waveforms, spectra, detection rate, and false alarm rate (FAR). Also, it must provide an estimation of target distance, speed, and angles for the detected target.

PathWave System Design (SystemVue) as a Platform for Simulation

The top-level system platform structure is shown in Figure 4.1. From the block diagram, the main models include signal source, transmitter, antenna, T/R switch, RCS, clutter, jammer, receiver, signal processors, and measurements. Sub libraries are also listed. The major task is how the designer creates their algorithm using SystemVue.

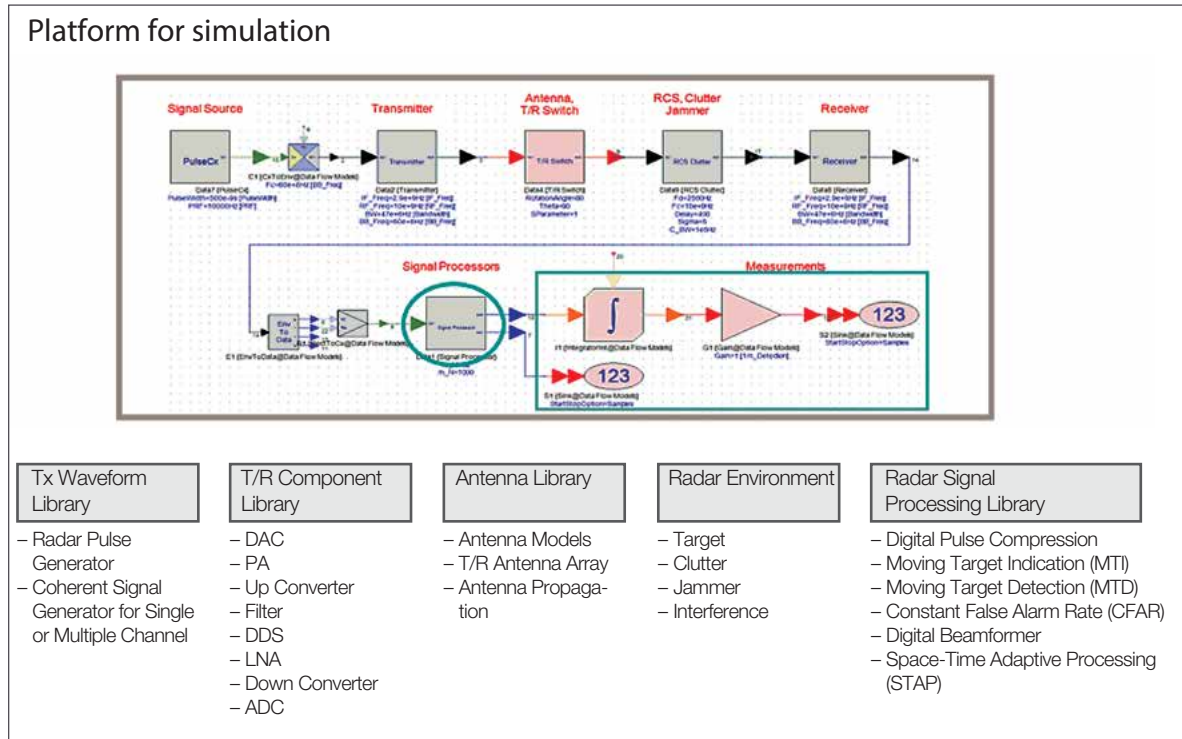

Figure 4.1. SystemVue as a platform for simulation

SystemVue as a Platform for Test

SystemVue can be used as a test platform for verification of the integrated system at each stage of development. This is done by connecting algorithms, instruments, and test hardware together based on the created algorithm.

In SystemVue, an interface model (sink) allows for direct connections with various signal generators as shown in Figure 4.2. This allows software data to be downloaded to instruments for hardware test data. Figure 4.3 shows the details for using the platform to connect to instruments and test hardware based on the created algorithm.

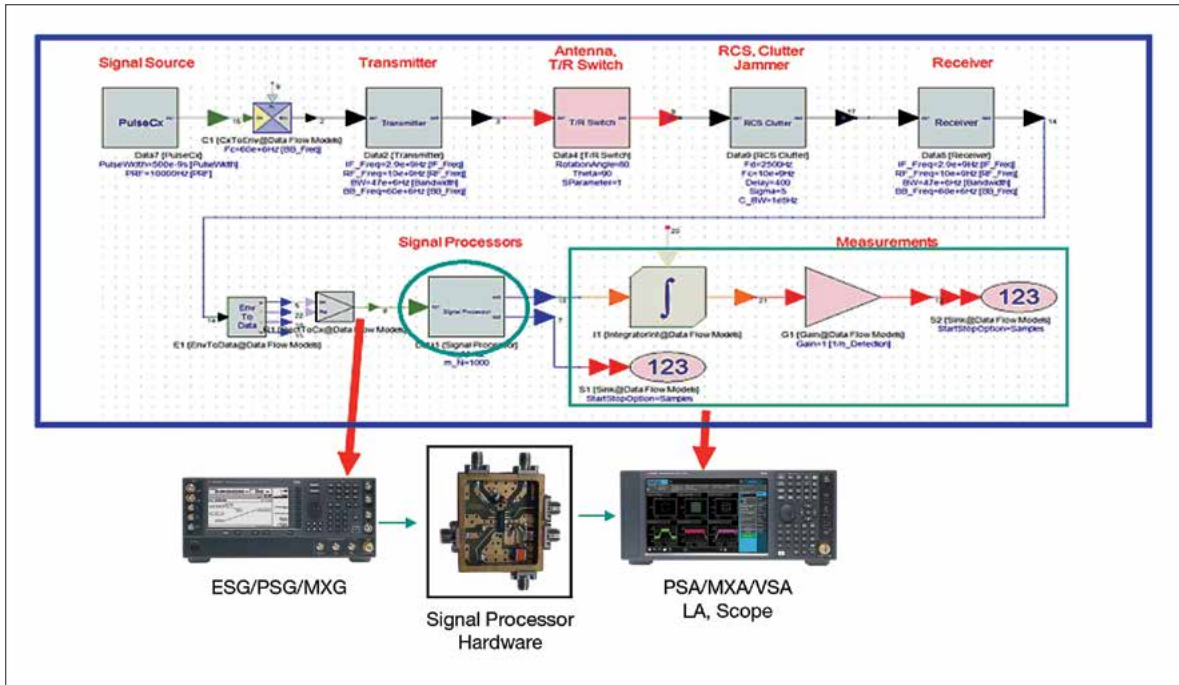

Figure 4.2. SystemVue as a platform for test

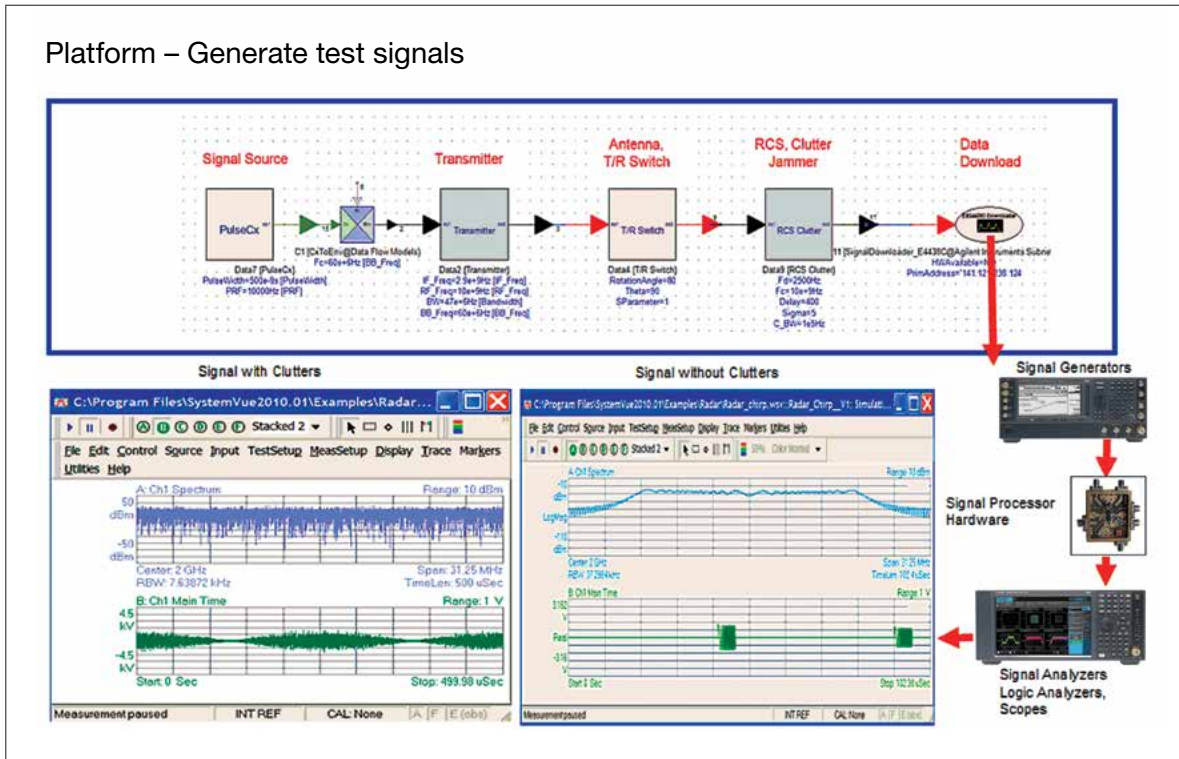

Figure 4.3. Generate test signals using SystemVue

Platform – Expand measurements

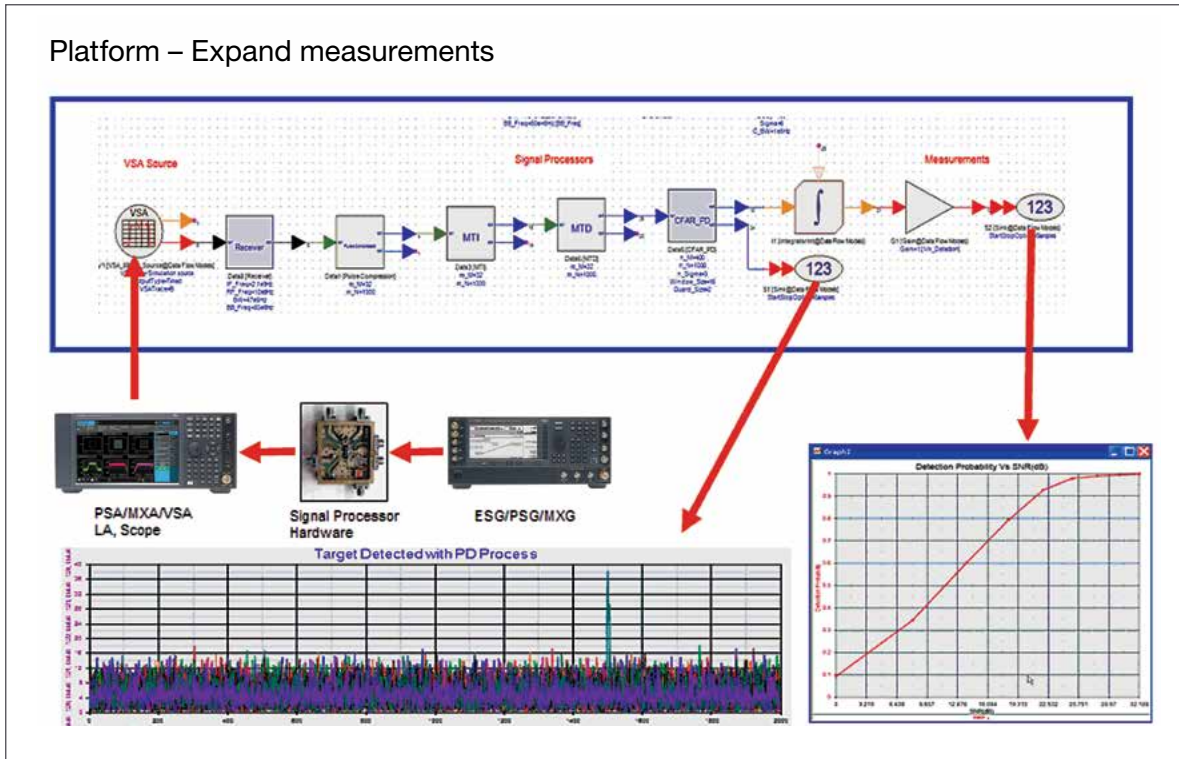

Figure 4.4. Expanding measurement capabilities using SystemVue

SystemVue can also connect to signal analyzers, logic analyzers or scopes to provide additional measurements and expand instrument capability according to the user's needs. As an example, Figure 4.4, shows the link between SystemVue and a signal analyzer. Here, test signals from the signal generator are sent to the device-under-test (DUT). The signal analyzer captures the DUT output waveforms and sends them to SystemVue, using the Vector Signal Analyzer (VSA) link model. In SystemVue, the waveform can be further processed using the radar signal processing function. SystemVue also provides additional measurements such as Doppler frequency, detection probability, and false alarm probability.

Principles of the PD Radar System

To better understand the proposed system design methodology, consider the design of PD radar algorithms. PD are extremely valuable for finding small moving targets hidden by heavily cluttered environments and are used in both military and commercial applications. Unlike continuous waveform (CW) radar, PD radar has the ability to detect angle, distance, and velocity. Typical examples include weather, low-flying aircraft, and anti-ship missiles.

For this discussion, we focus on airborne PD radar that is trying to detect a moving target near the ground or the sea. In this case, the moving target returned signal is much weaker than the clutter from the ground or sea. As shown in Figure 4.5, the target signal is hidden by a heavily cluttered environment. Consequently, it is almost impossible to detect the target in the time domain using regular radar processing.

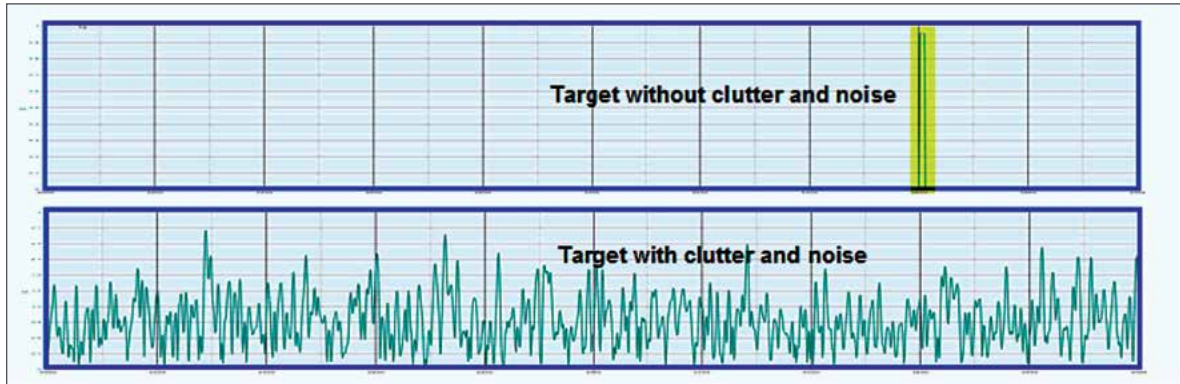

Figure 4.5. Target signal hidden by heavily cluttered environment

The radar transmission signal and returned signal [1] can be expressed as:

$$S(t) = A(t)\cos(2\pi f_c t)$$

$$S(t - \tau) = A(t) \cos(2\pi (f_c + f_d) t - \tau) + N_c(t) + N_n(t) + N_j(t)$$

where f_d is the Doppler frequency, τ is the delay, and N_c , N_n and N_j refer to clutter, noise and jamming, respectively. To detect target, speed, and distance, f_d and τ must be estimated.

Because the small moving targets are hidden by the heavily cluttered environments, they cannot be detected in the time domain. Instead, the signal must be detected in the frequency domain using Doppler frequency analysis. To do this, return data must be collected and processed using two-dimensional (2D) signal analysis for both target, speed, and distance. 2D signal processing is required for moving target indicator (MTI) and MTD. CFAR processing is needed for auto-detection in PD signal processing. Without CFAR, auto-detection will likely fail.

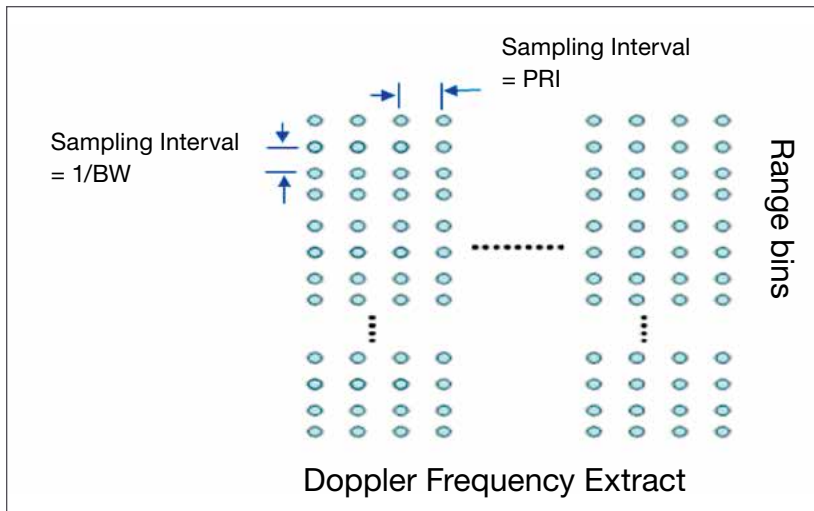

Figure 4.6. 2D signal processing for moving target detection

The first step in PD signal processor development is to design a data bank to store received timed signals, as shown in Figure 4.6. The received data is entered into the data bank point-by-point from one column to another until the bank is full.

Taking a closer look at each column, the time interval for each data point is $1/\text{bandwidth}$. Each data point is a return signal from different distances. The sampling interval between each column is the pulse signal repetition interval. All data points in the same row are returned from the same distance with different timing. Doppler frequency can be extracted from data in the rows. Either a filter bank or a group of fast Fourier transform (FFT) operations can be used for all data points in the data bank. In software design, a group of FFTs is always used. Once the Doppler frequency is detected, the location of the row can be mapped to the return target distance from the range bins. Then, the distance can be detected.

PD Radar System Structure

Figure 4.7 depicts the top-level structure of a PD radar system in SystemVue. Since we are interested in creating an algorithm for PD signal processing, this discussion focuses on PD signal processing, including MTD and CFAR. For other blocks, just a brief introduction is provided.

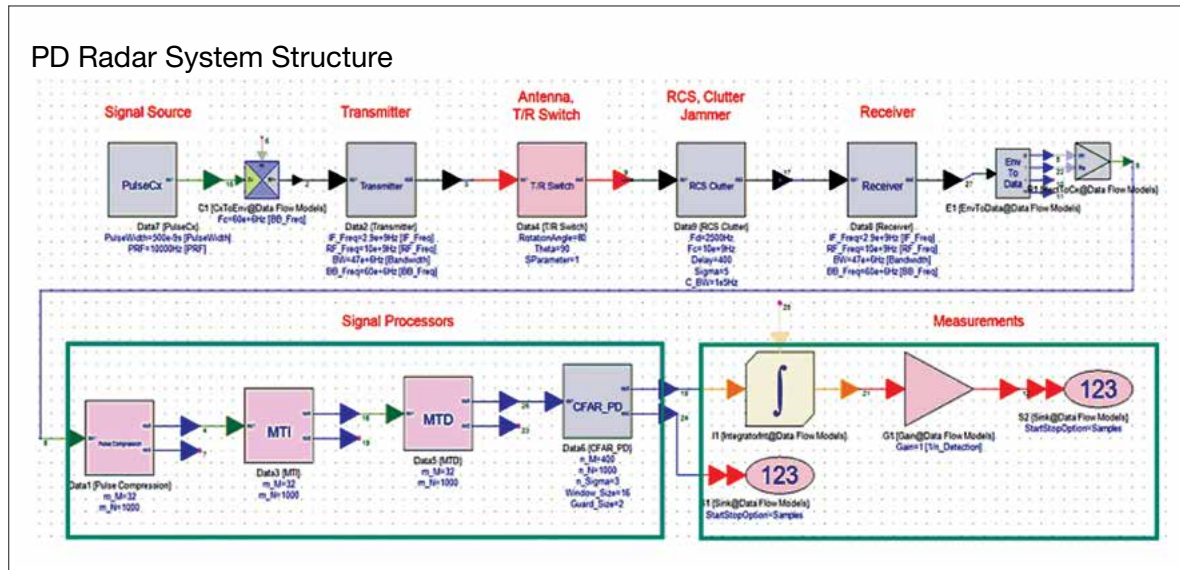

Figure 4.7. PD radar structure

Signal sources

For this example, signal sources include:

- Pulse signal generator
- Linear FM pulse signal generator
- Nonlinear FM signal generator
- Polyphase code generator

Target return model

The target return model includes:

- RCS, Doppler effect, delay, and attenuation
- Fluctuant RCS types: Swirling 0, I, II, III, and IV linear FM pulse signal generator

$$S_r(t - t_r) = k A(t - t_r) \cos [2 \pi (f_0 \pm f_d) t - 4\pi R_0 / \lambda + \rho] \cdot U(t - t_r)$$

where R_0 is the distance between radar and the target, and t_r is the path delay, so $t_r = 2R_0/c$.

Clutter models

Since this is the system-level simulation, behavioral models can be used to describe the functionality. We focus on the probability distribution functions (PDFs) and power spectrum densities (PSDs) that are acceptable to model the system performance, but the physical-level model is not provided here. If required by the user, this service can be provided. SystemVue offers a choice of four PDFs and three PSDs, which include:

PDF

- Rayleigh
- Log-Normal
- Weibull
- K-Distribution

PSD

- Gaussian
- Cauchy
- All Pole

The user can also define any distribution using SystemVue's built-in MATLAB Script capabilities.

Radar RF transmitters and receivers

Here we provide the behavioral model's structure. If desired, the SpectraSys RF link enables the user to go down to the circuit level. Another way to model complex frequency-dependent behavior is to import S-parameters using the SData model. An example of using the SData model is shown in Figure 4.11.

As shown in Figure 4.8, the RF transmitter features local oscillators, which can include phase noise, modulators and mixers with non-ideal behavior, and amplifiers which can include complex nonlinear behaviors and filters. Figure 4.9 depicts the RF receiver's oscillators, demodulator, amplifiers, and filters.

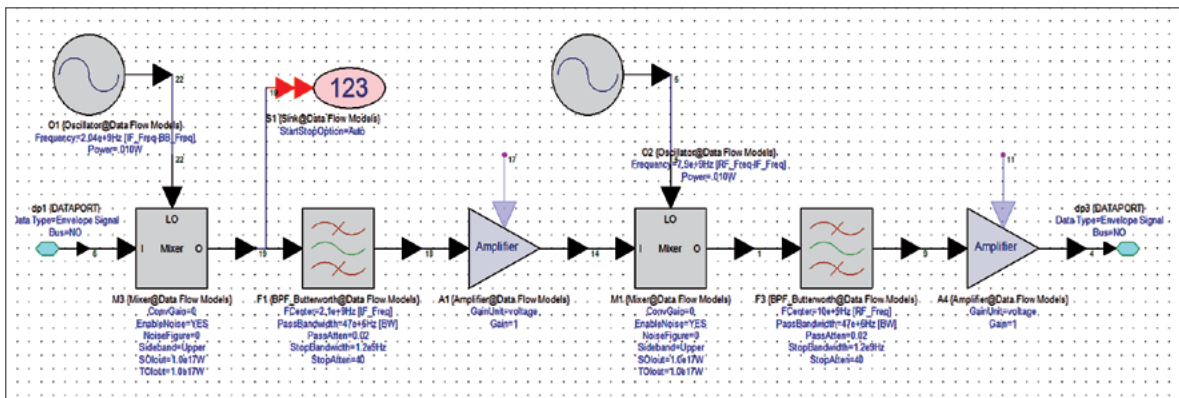

Figure 4.8. RF transmitter

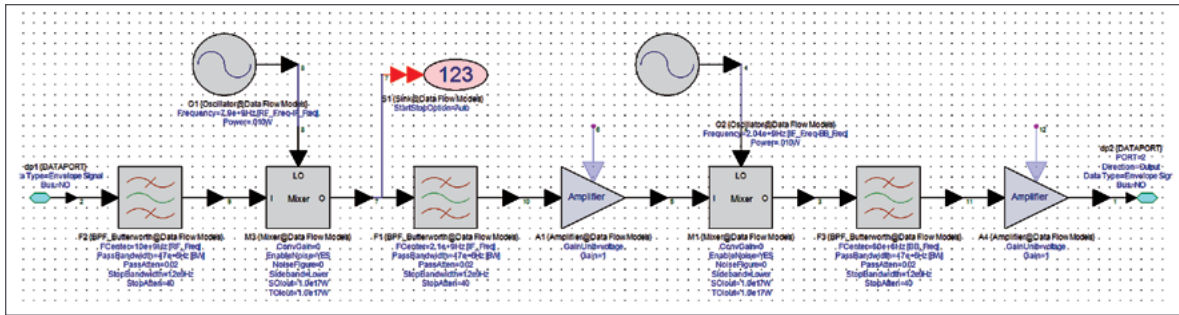

Figure 4.9. RF receiver

Digital up/down converter (DUC/DDC) for digital IF

The two models depicted in Figure 4.10 are very useful for creating new DSP models with certain algorithms.

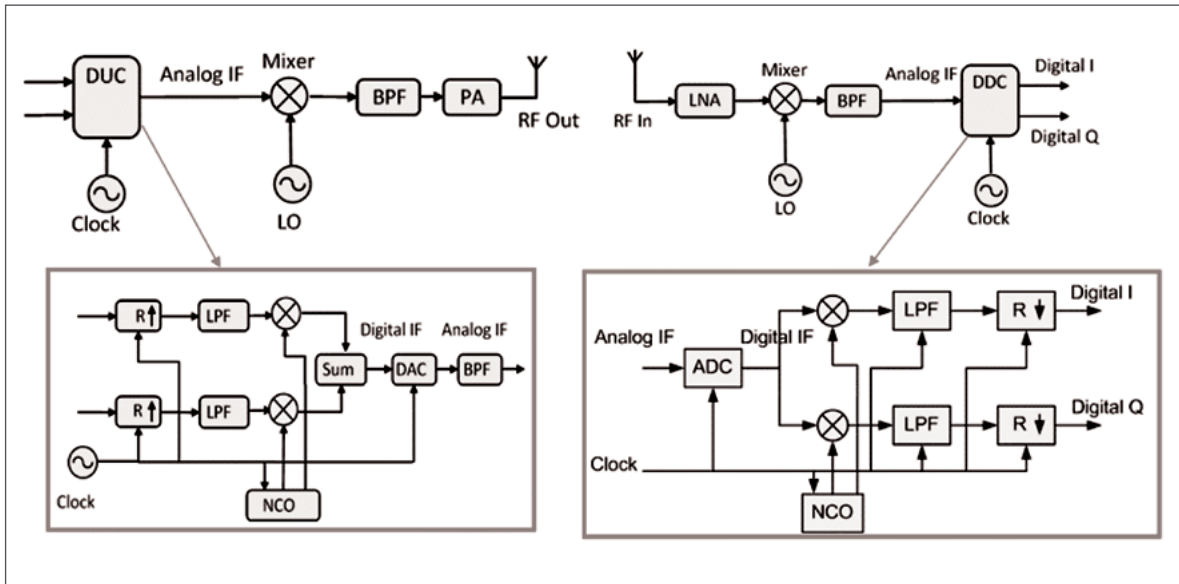

Figure 4.10. Digital up/down converters

Antenna models

The antenna model structure shown in Figure 4.11 was created using a SystemVue SData model. If the user knows the antenna's Gain as a function of Deflection Angle, Modeled with S-parameters, the simulation model can be easily structured. Figure 4.11 also shows the antenna measurements.

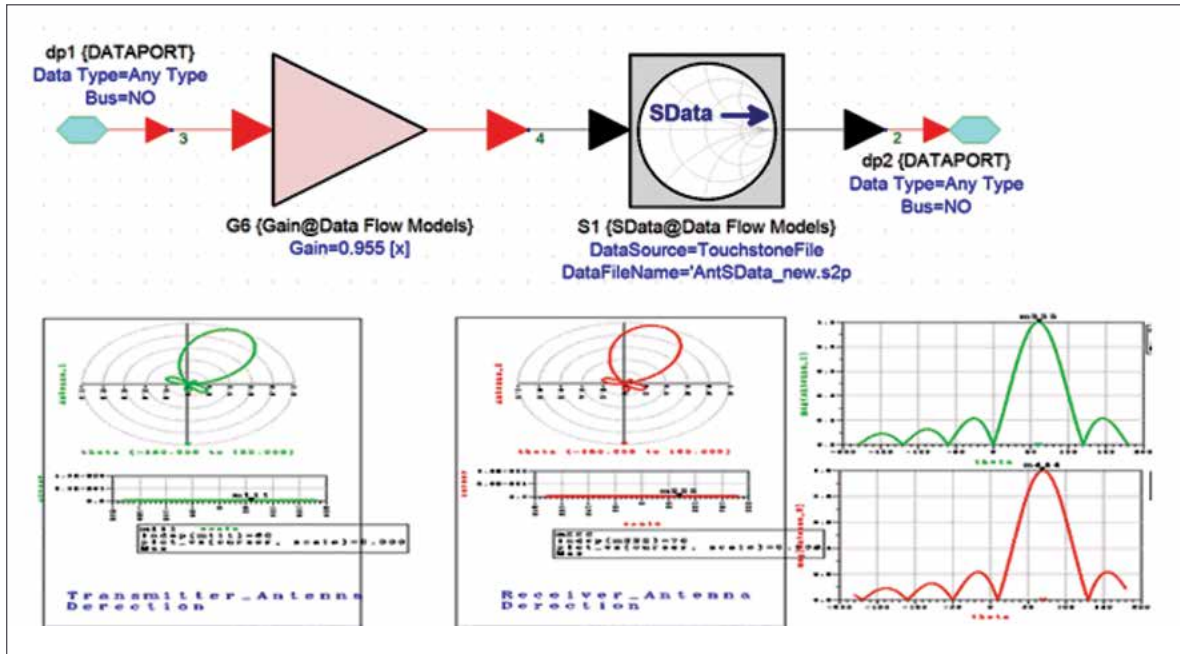

Figure 4.11. Antenna structure

Pulse compression

Figure 4.12 depicts the PD processing pulse compression.

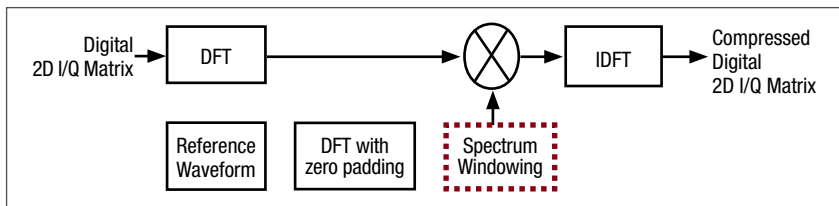

Figure 4.12. Pulse compression in frequency domain for PD processing

Moving target indicator

The basic idea behind the MTI is to filter the clutter at or very near DC, while keeping the other spectrum region flat. As shown in Figure 4.13, a three-pulse (double, second-order) canceller can be formed by cascading two first-order sections using a transfer function.

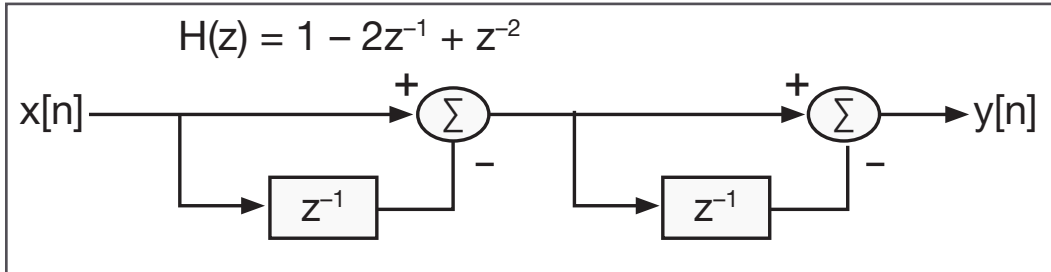

Figure 4.13. Moving target indicator

Moving target detector

The MTD is a key processor for PD radar [2]. A bank of Doppler filters or FFT operators cover all possible expected target Doppler shifts (Figure 4.14). The input data is collected in a repetition period by using a data bank. Data points within the same range are then correlated and processed until all data in the data bank is processed. There are two ways to administer the 2D signal processing, either using a filter bank or a group of FFT. In the example, a group of FFTs is used to operate on each row in the data bank to detect fd. Delay is then detected by looking at the detected data point location for range bins.

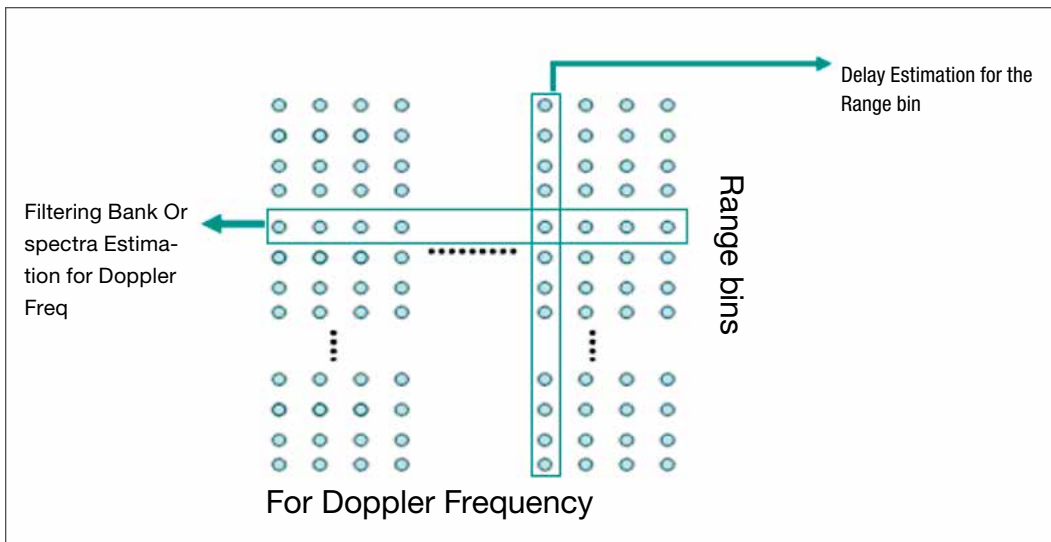

Figure 4.14. Signal processing in MTD

Once the algorithm is understood, the code can be derived using C++ or MATLAB Script. During its development, the code can be easily debugged for either C++ or users can modify the code or insert their own in the code window to implement their own MTD algorithm.

CFAR Processor

Since modern radar requires auto-detection, PD radar must use CFAR to control the false alarm rate. Otherwise, the radar won't work. The CFAR can be done in time, frequency domains, or both. Instead of the fixed detection threshold, the averaging amplitude value of reference cells is used as the threshold to prevent false alarms from happening too frequently. This CFAR system is called a cell averaging (CA) CFAR system.

In the PD radar example in this chapter, CFAR was done in the frequency domain. Cell averaging CFAR was used.

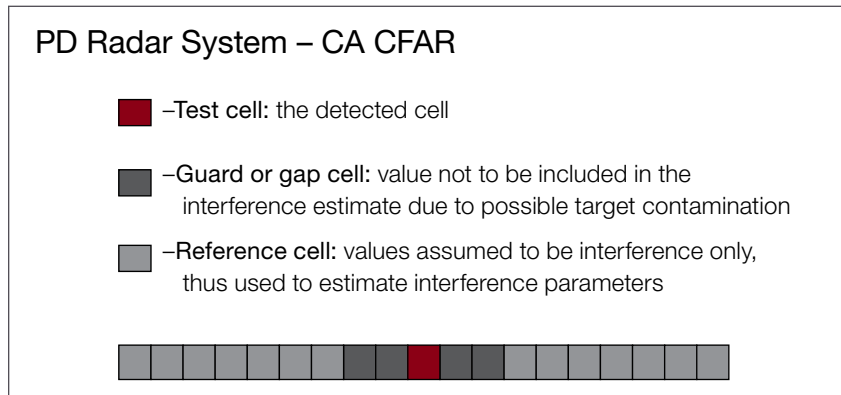

Figure 4.15. CA CFAR processor code implementation

Once the algorithm is understood, the code can be derived using C++ or MATLAB Script. During its development, the code can be easily debugged for either C++ or MATLAB Script as shown in Figure 4.15. Users can modify the code or insert their own in the code window to implement their own CFAR algorithm.

Measurements

Models have been implemented to do the following measurements:

- Basic Measurements
 - Waveform
 - Spectrum
 - Signal noise ratio
- Advanced Measurements
 - Estimation of distances and speeds
 - Detection probability, P_d = number of successful detection/total number of tests
 - False alarm probability, P_f = number of false errors/total number of tests
 - Importance sampling will be implemented to speed up the P_f simulation [3]

If the user wants more, custom measurement models can be created using a combination of existing models.

Simulation of PD Radar System

The PD design shown in Figure 4.7 is simulated. All key parameters can be set at the Parameter table defined for the PD simulation system as shown in Figure 4.16. The user can very easily edit, add or delete any parameter.

Name	Description	Default Value	Units	Tune	Show	Initially Use Default
PulseWidth	Pulse Width	500e-9 s		<input type="checkbox"/>	<input checked="" type="checkbox"/>	<input type="checkbox"/>
PRF	Pulse Repeat Frequency	10000 Hz		<input type="checkbox"/>	<input checked="" type="checkbox"/>	<input type="checkbox"/>
Fd	Doppler Frequency	8125 Hz		<input type="checkbox"/>	<input checked="" type="checkbox"/>	<input type="checkbox"/>
Range	Target Range	12000 M		<input type="checkbox"/>	<input checked="" type="checkbox"/>	<input type="checkbox"/>
RF_Freq	RF Frequency	10e9 Hz		<input type="checkbox"/>	<input checked="" type="checkbox"/>	<input type="checkbox"/>
IF_Freq	IF Frequency	2.9e9 Hz		<input type="checkbox"/>	<input checked="" type="checkbox"/>	<input type="checkbox"/>
BB_Freq	Baseband Frequency	60e6 Hz		<input type="checkbox"/>	<input checked="" type="checkbox"/>	<input type="checkbox"/>
Bandwidth	Band Width	47e6 Hz		<input type="checkbox"/>	<input checked="" type="checkbox"/>	<input type="checkbox"/>
SamplingFreq	Simulation Sampling Frequency	120e6 Hz		<input type="checkbox"/>	<input checked="" type="checkbox"/>	<input type="checkbox"/>
FFTSize	FFT Size	32 ()		<input type="checkbox"/>	<input checked="" type="checkbox"/>	<input type="checkbox"/>
n_M	Detection Cell	400 ()		<input type="checkbox"/>	<input checked="" type="checkbox"/>	<input type="checkbox"/>
Window_Size	CFAR Window Size	32 ()		<input type="checkbox"/>	<input checked="" type="checkbox"/>	<input type="checkbox"/>
Guard_Size	CFAR Guard Size	6 ()		<input type="checkbox"/>	<input checked="" type="checkbox"/>	<input type="checkbox"/>
Sigma	Clutter Standard Diviation	2.5 ()		<input type="checkbox"/>	<input checked="" type="checkbox"/>	<input type="checkbox"/>
C_BW	Clutter Bandwidth	1e6 Hz		<input type="checkbox"/>	<input checked="" type="checkbox"/>	<input type="checkbox"/>
RotationAngle	Antenna Rotation Angle	60 deg		<input type="checkbox"/>	<input checked="" type="checkbox"/>	<input type="checkbox"/>
Theta	Antenna Angle	90 deg		<input type="checkbox"/>	<input checked="" type="checkbox"/>	<input type="checkbox"/>
n_Sigma	Noise Standard Diviation	3 ()		<input type="checkbox"/>	<input checked="" type="checkbox"/>	<input type="checkbox"/>
n_Detection	Number of statistics for the detec	1 ()		<input type="checkbox"/>	<input checked="" type="checkbox"/>	<input type="checkbox"/>

Figure 4.16. Simulation setup table

Simulation results

Before PD processing, at the receiver input, the target signal cannot be recognized, and the target is hidden by a strong clutter environment (Figure 4.17). However, after the 2-D PD processing, the target is detected. After PD and CFAR, clean target detection is achieved.

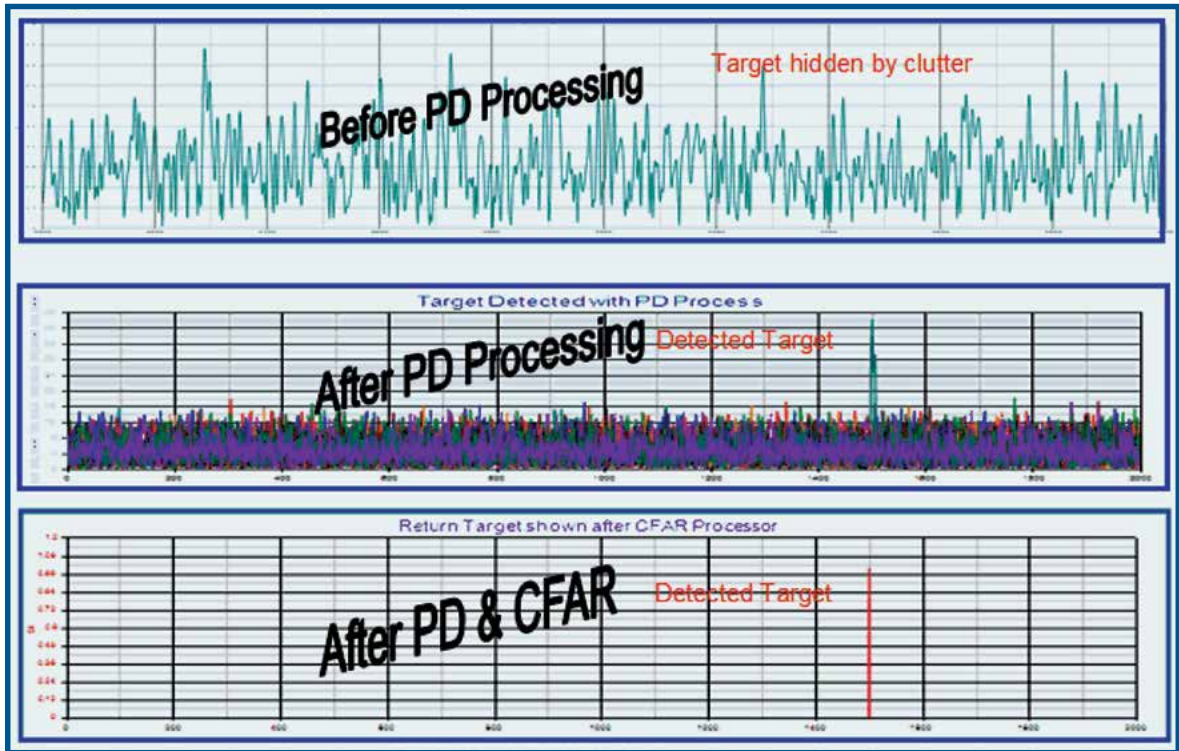

Figure 4.17. PD detection of a moving target

In Figure 4.18, the detection probability of the system is displayed. The detection rate is obtained by running several tests and using the Pd definition to obtain it. The target distance and speed are estimated using the detected Doppler frequency and the detected range bin location.

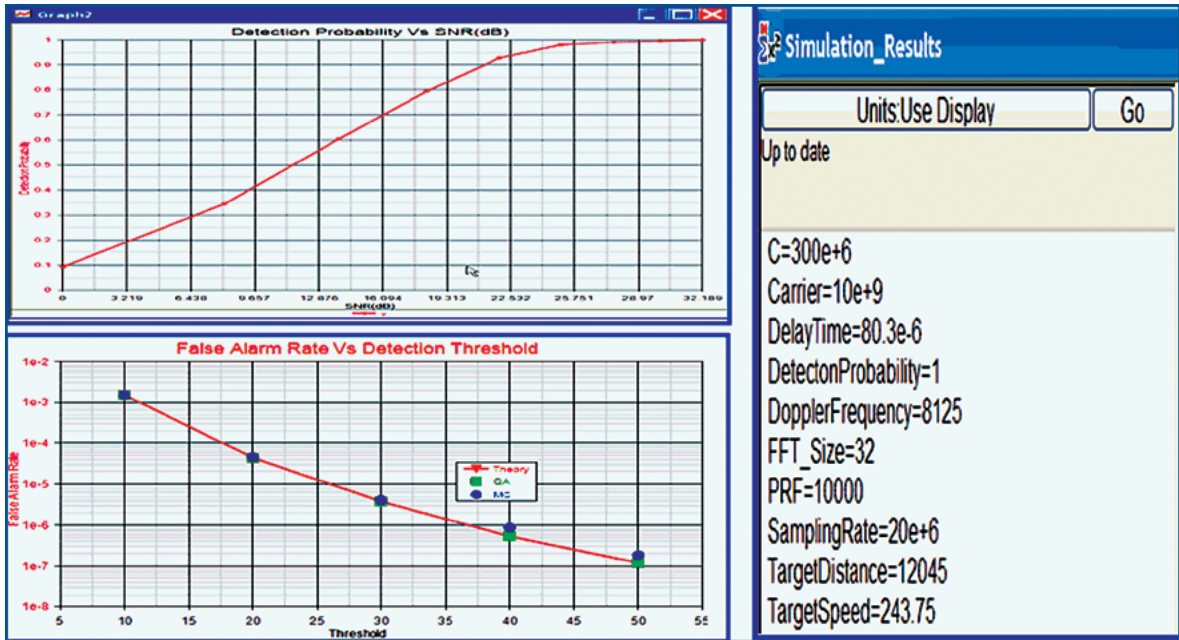

Figure 4.18. System detection rate and estimated target distance and speed

Algorithms are critical for high-performing advanced radar systems. A unified approach to radar system design that relies on SystemVue now offers designers a viable means of creating effective algorithms. It provides a user-friendly environment for algorithm development, while also integrating software and hardware to verify the algorithms. SystemVue can even be used to develop algorithms for digital array radar plus spacetime adaptive processing (STAP) and multiple-input multiple-output (MIMO) radar. Moreover, it allows the system development team to quickly and easily try new and innovative ideas and to evaluate the effects of jamming and interference sources on radar performance.

References

1. I. Skolnik, Radar Handbook, 2nd ed. McGraw-Hill Inc., 1990.
2. D. Curtis Schleher, MTI and Pulse Doppler Radar, Artech House, Inc., 1991.
3. Dingqing Lu and Kong Yao, Importance Sampling Simulation Techniques Applied to Estimating False Alarm Probabilities, Proc. IEEE ISCAS, 1989, pp. 598-601.



Chapter 5 Applying Ultra-Wideband Technology in Radar and EW Systems

Integrating Design with Ultra-Wideband Test for Flexible Radar Verification

Ultra-wideband (UWB) radar has become increasingly popular in both commercial and defense industries. UWB radars (whether impulse, LFM, noise, or OFDM-based) are defined as having a bandwidth of greater than 0.5 GHz, or more than 20% of their center frequency, and are regulated by FCC rules that allow UWB technology to coexist with existing radio services without causing interference. They offer several advantages including high accuracy for target detection, good precision for penetrating radars, and low cost for combining radar and communication systems. UWB radars can pass through walls and other obstacles for geolocation/positioning and can support multipath immunity and frequency diversity with minimal hardware modifications.

Modern UWB radar systems often operate in unpredictable environments, with interference, jamming, and other “real world” performance limitations. Therefore, during system development, it is critical for engineers to understand how their actual hardware will perform in these environments.

Problem

Effective radar system design requires comprehensive system validation, a time-consuming and expensive process often necessitating costly facilities and complex measurement systems. Radar algorithms, such as target recognition and countermeasures, need to be validated early enough to change the signal processing hardware design. Hardware receivers must also be tested with realistic threats and jamming scenarios. Together, these often require outdoor ranges, chambers, and real-time hardware simulators costing tens of thousands of dollars per hour.

Unlike communication system designers, UWB radar system designers face several unique challenges, beyond sheer bandwidth. Impulse radar signals, for example, can change shape during propagation (e.g., non-sinusoidal waveforms), while for noise-like radars, figuring out how to model the noise in the waveform can be challenging. With Linear FM systems, generating UWB signals with Doppler frequency offsets, target echoes, and clutter to perform receiver verification can be challenging. As a result, designing and testing UWB radar systems requires a variety of signal sources, target environment setups, and measurements. Carefully designed and optimized waveforms are essential to ensure excellent real-world performance.

Solution

To successfully develop UWB radar systems, today's system engineers require a more flexible, lower-cost means of validation with stimulus/response equipment that is specifically geared toward UWB. That R&D test bed starts with Electronic Design Automation (EDA) software to model a working reference design. The reference design is used to generate test vectors, as well as process received signals that are captured from live measurements and organize a "model-based design flow." The test bed also includes a UWB signal generator with a wideband arbitrary waveform generator (AWG) to render simulated signals, including realistic threats and jamming scenarios, for testing UWB hardware receivers. Finally, the UWB test bed should include a wide-bandwidth oscilloscope for waveform capture.

An additional role of the EDA software is to surround the raw radar design and test equipment with the environmental, baseband, and RF modeling required to close a round-trip signal processing loop to perform early simulation-based verification. As hardware becomes available, the software continues to connect directly into the physical hardware measurement. By leveraging the design tools into verification, a consistent approach is maintained throughout the research and development process saving time, promoting re-use, and making optimum use of the capital equipment assets.

Keysight provides an example of just such a test system. As shown in Figure 5.1, the system starts with the SystemVue simulation and modeling environment, which is used with a wideband AWG (upper left), the vector signal generator (lower right) and the 32 GHz oscilloscope (lower left). Together, these components allow engineers to carefully design and optimize the UWB signals that are so critical to the design, verification, and test of UWB radar systems.

The test bed shown in Figure 5.1 supports investigations of UWB architectures, as well as a direct connection to test equipment for verification. It can be used to model, encode, and download UWB test signals and also post-process received signals. The wide-bandwidth 90000 X-Series oscilloscope allows RF engineers to measure and analyze UWB radar transmitter outputs using up to 32 GHz of true analog bandwidth, without the need for external down-conversion. This direct approach reduces hardware calibration, system impairments, and measurement system complexity and uncertainty.

Keysight's E8267D PSG microwave vector signal generator features wideband baseband IQ inputs. When combined with a wideband AWG, such as the 81180A, M9330A, or the new M8190A, the PSG provides the flexibility necessary to create microwave and millimeter-wave signals for UWB radar scenarios, as well as component validation.

With this test system, SystemVue generates and downloads different UWB radar test vectors to the wideband AWG to create the necessary baseband signals. The output differential IQ signals of the AWG are then modulated by the PSG to create an X, Ku, or Ka band test signal, to be used directly as an input to a device under test (DUT) for the radar component test. Next, the output of the DUT is captured using the Infiniium 90000 X-Series oscilloscope where radar measurements can be made (Figure 5.2). Signals can be analyzed inside the Infiniium oscilloscope using the Oscilloscope Signal Analyzer (OSA) or Vector Signal Analysis (VSA) software. For further analysis and signal processing, measured signals up to 32 GHz

wide can be brought back to SystemVue with the help of the 89600B VSA software, to close a unique “round trip” signal processing loop (Figure 5.2).

Because of the versatility of this UWB test bed, it can be used for both validation and troubleshooting of UWB transmitters and UWB receivers.



Figure 5.1. With SystemVue integrating this UWB test platform with a working radar reference design, engineers can precisely generate and measure UWB waveforms for any point in a UWB system architecture, and perform closed-loop stimulus/response measurements that reduce the need for expensive ranges, chambers, and hardware simulators in early R&D.



Figure 5.2. SystemVue, in combination with best-in-class AWG and oscilloscope test families, provides a closed-loop, stimulus/response modeling, and verification platform up to 32 GHz wide. It enables a versatile and cost-effective UWB system-level approach in R&D.

UWB Waveform Creation

Carefully designed and optimized waveforms can be created using SystemVue running within the Infiniium 90000 X-Series oscilloscope, or on an external PC. SystemVue plays a critical role in UWB waveform creation by providing a workspace with open, parameterized signal processing diagrams for LFM, pulse, and noise UWB radar signal generation. Transmitter signals can be generated for Linear and Nonlinear FM pulses and coded signals; sort pulse signals with Gaussian windowing; and noise UWB radar. Radar target return signals with radar cross-section (RCS), clutter, jamming, and interferers can also be generated.

Before downloading to test equipment, the simulated waveforms can be verified in SystemVue for conformance to both frequency- and time-domain specifications. SystemVue also enables engineers to incorporate custom signal processing intellectual property (IP) and create custom signals that integrate C++ dynamic link libraries, MATLAB models, VHDL, and test vector data files.

Example: LFM UWB Transmitter/ Receiver Signals

To better understand how easily UWB radar transmitter and receiver signals can be generated and measured, consider the example of LFM UWB transmitter/receiver signals. Using the test platform shown in Figure 5.2, an LFM UWB transmitter signal is created with 1 GHz bandwidth, 1 microsecond of pulse-width, and a 10-microsecond repetition interval. It is generated using SystemVue with the 81180 AWG, the PSG, and the 90000 X-Series oscilloscope (Figure 5.3).

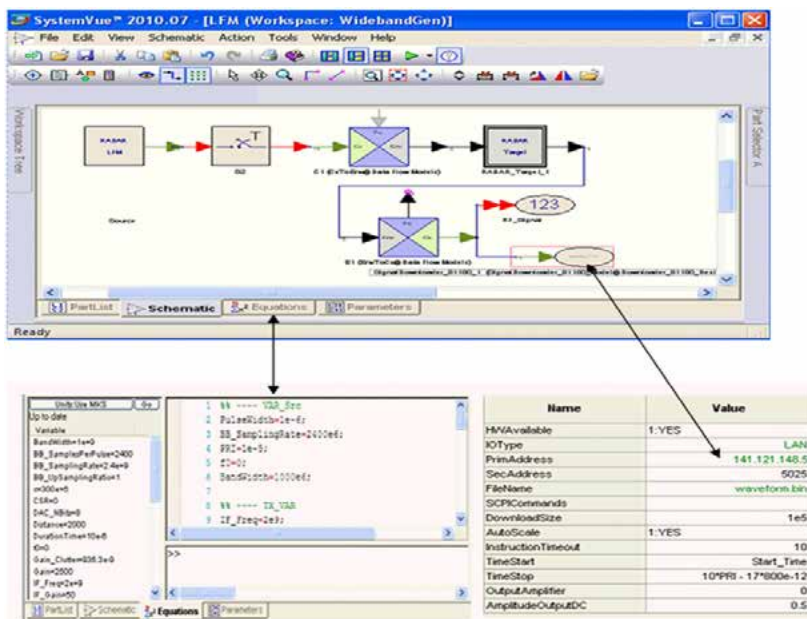

Figure 5.3. An LFM design in SystemVue (upper image) is used to generate a UWB signal. The final block in the system-level schematic captures the simulation result and downloads the waveform data into the 81180A AWG using the parameters shown (lower right). Then, the 81180 (not shown) repeats the generated signal for hardware testing

The LFM UWB transmitter signal is then measured using VSA software with a pre-stored configuration file. The results are shown in Figure 5.4.

For receiver component test, the same equipment is used to create an LFM UWB receiver signal for a target with a 100 meter range and a 20 m/s velocity. The 89600B VSA software is used to capture the LFM UWB receiver signal. The VSA measurement is configured using a stored “setup” file which is quickly recalled at the simulation runtime.

Note that for either OFDM type transmitter signals, the impulse or OFDM UWB source objects must first be activated in the SystemVue simulation to generate the respective UWB signals. Like the LFM UWB signals, these alternate types of UWB signals can be measured using the VSA software.

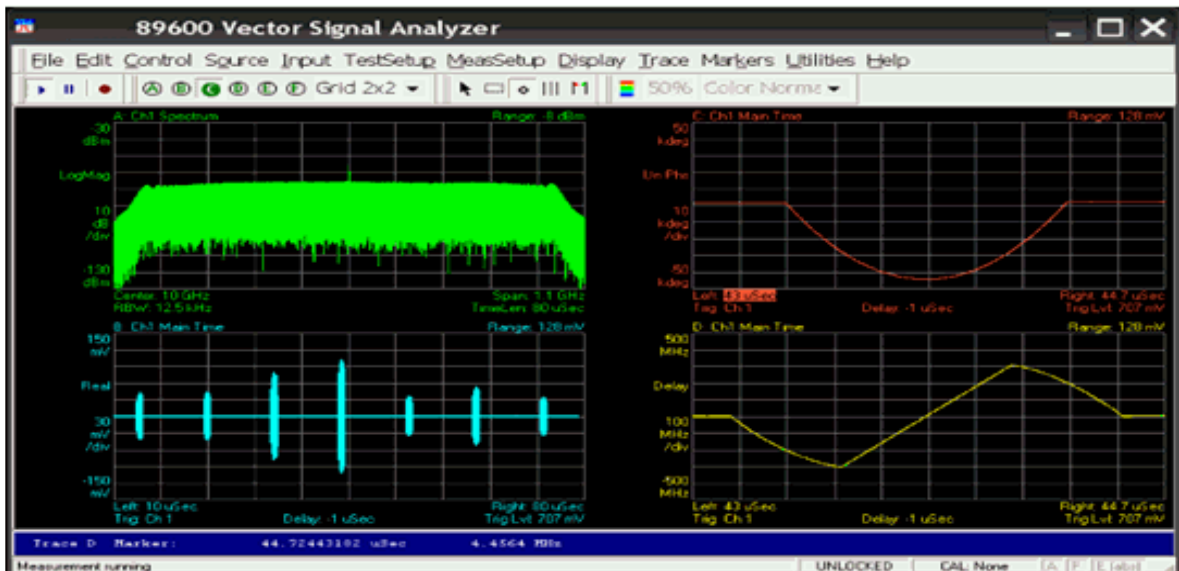

Figure 5.4. Shown here is a 1-GHz LFM UWB signal. The upper left image shows the 1-GHz wide radar spectrum centered at 10 GHz, while the log magnitude envelope versus time is shown just below it. The signal phase is shown on the upper right graph. The 1 GHz-wide LFM chirp is displayed on the lower right graph.

Summary of Results

Designing, verifying, and testing UWB radar systems requires precisely controllable UWB signals. Unfortunately, generating and measuring the required UWB radar signals is no easy task. Keysight's SystemVue with a wideband AWG and the PSG signal generator provides a "simulatable" UWB radar reference design and working waveforms that engineers can use to test and troubleshoot UWB radar transmitter and receivers, thus reducing development effort. When Keysight's 90000 X-Series oscilloscope is added, radar transmitter and receiver measurements can also be performed, completing a full "roundtrip" signal processing path for radar architecture validation up to 32 GHz wide. Together these instruments create an interactive UWB test system that can be used to optimize UWB system architectures conveniently and cost-effectively, as well as to verify individual RF and baseband components over challenging bandwidths and signal conditions.



<https://www.keysight.com/see/radar-ew-system-design>

Chapter 6

Dealing with the Complexity of Phased-Array Systems

Phased array is widely used in modern radar systems for rapid multi-target search and track operations, as well as to achieve higher resolution, and better detection performance. Despite these enviable benefits, when developing phased array radar, many issues may be encountered. For modern engineers, that often means a myriad of test challenges, such as finding a way to improve performance while also reducing the high cost of Transmit/Receive (T/R) modules with Direct Digital Synthesizers (DDSs), digital-to-analog converters (DACs), and Analog-to-Digital Converters (ADCs). Also of concern to the engineer is finding a way to work effectively with the entire development team—the system architect, the RF team, and the signal processing team. Additionally, calibration of the T/R module can be difficult, not to mention time-consuming and expensive. Addressing these challenges demands an appropriate method of designing and testing phased-array radar systems; one that streamlines the R&D lifecycle so that faster, cheaper, and better phased-array radar systems can be achieved.



Phased-Array Radar Design: The Basics

There are two types of phased-array radar systems: passive and active (Figure 6.1). In a passive system, a baseband source is connected to a single large Transmitter (Tx) with a High-Power Amplifier (HPA). The Tx is connected to a beamformer followed by the antenna unit, the return signals of which are connected to a single receiver (Rx) and subsequently, to the baseband receiver. In passive systems, the signal loss between radiating elements and the T/R can be quite large. However, because passive antenna systems have a central Radio Frequency (RF) source, developing a radar system based on a Passive Electronically Scanned Array (PESA) is a straightforward process. The same cannot be said of radars based on an Active Electronically Scanned Array (AESA). In contrast to a PESA radar, AESA devices have T/R modules containing small Tx and Rx designs located behind each radiating element, and the baseband source is connected to the beamformer. Transmitter power is distributed through many small PAs to the antennas, while the baseband receiver receives signals through antennas in many small Low Noise Amplifiers (LNAs). In an active system, the signal loss between the PA/LNA and the radiating element is much smaller than in a passive system. Electronic scanning is therefore used, which enables faster, more flexible searching. However, because each module contains its own RF source, development of AESA radars is substantially more complex.

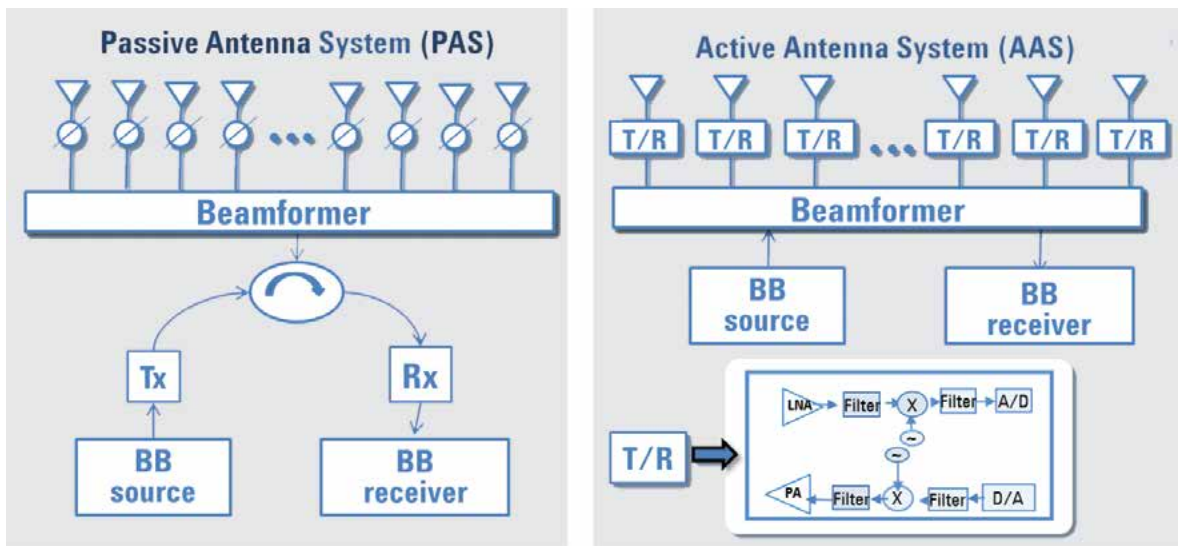

Figure 6.1. Two types of phased-array radar, passive-array and active-array antenna systems, are shown here.

The Platform Solution

Dealing with the complexity of AESA radar development, while also addressing the traditional problems and challenges associated with developing a phased-array radar requires a platform solution that enables effective design and tests at every stage of the development process (Figure 6.2). The ideal platform solution relies on simulation as its foundation and features several key characteristics, including cross-domain simulation with RF and Electromagnetic (EM), as well as the ability to measure both 3D and 2D antenna patterns. The measured antenna patterns, coupled with Tx measurements (e.g., waveform, spectrum, and time-side-lobes) and Rx measurements (e.g., detection rate and false alarm rate) can be used for performance validation.

The platform solution also offers trade-off analysis, T/R module and antenna unit failure analysis, and adaptive algorithm creation support. It features links to test equipment (e.g., a signal generator, arbitrary waveform generator (AWG), and signal analyzer) for hardware testing, along with support for integrated testing. The links allow data to be downloaded to an AWG for testing RF signals and hardware signals to be acquired and sent back to simulation for post-analysis. A prime example of this platform solution is PathWave System Design, (SystemVue).

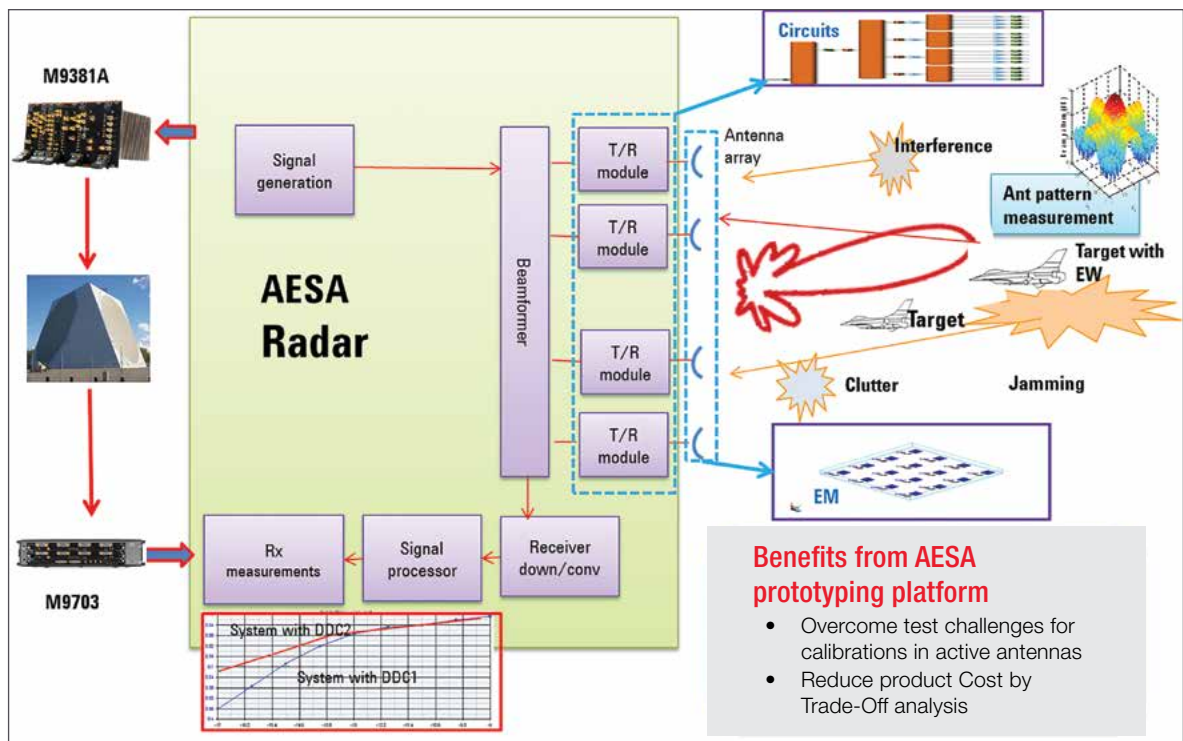

Figure 6.2. This platform solution for AESA radar relies on simulation at its core, in this case, the SystemVue simulation software from Keysight Technologies, Inc.

Key Models in the Platform

- **Direct Digital Synthesis (DDS)**

DDS is a key model for any digital radar and is frequently used in AESA radar for T/R module design (Figure 6.3). It is a digital radar source for generating digital waveforms, such as Continuous Wave (CW), pulse, Linear Frequency Modulation (LFM) pulse, stepped pulse, and stepped LFM as seen from the downloaded I, Q waveforms, LFM, CW, pulse, and LFM pulse.

- **Target model**

When evaluating receiver performance, the radar environment has to be considered, which makes creating a practical target model very important (Figure 6.4). While other commercial radar simulation products rely on an ideal radar equation for this model, SystemVue offers a much more practical target model.

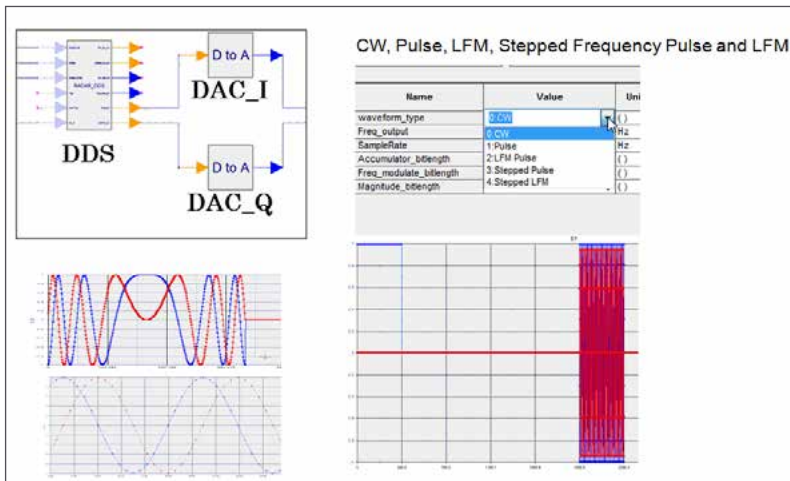

Figure 6.3. A DDS model is shown here.

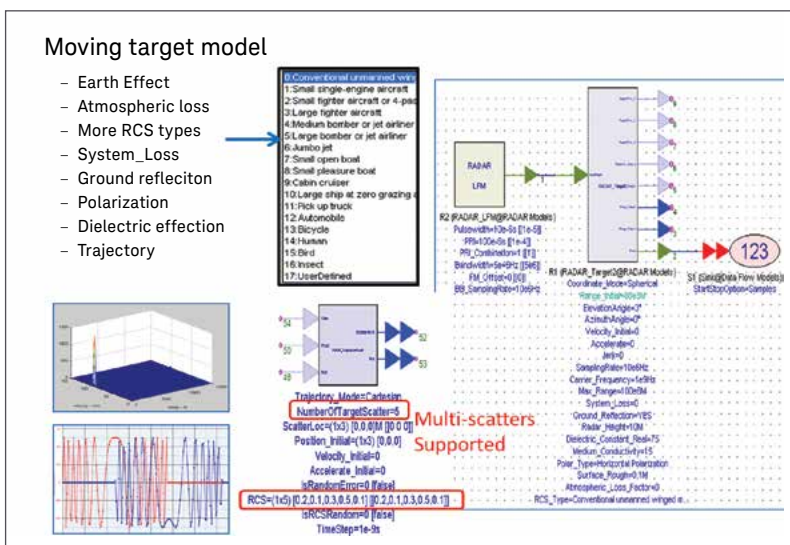

Figure 6.4. Illustrated here is a target model.

The radar environment includes terrain and sea surfaces, the atmosphere (including precipitation), and the ionosphere. These conditions may degrade radar observations and performance by producing clutter and other spurious returns, signal attenuation, and bending of the radar-signal path, including radar cross section (RCS), Doppler, delay, attenuation, and propagation effects.

Even though “free space analysis” may be adequate to provide a general understanding of a radar system, it is only an approximation. To accurately predict radar performance, the free space analysis must be modified to include the effects of the earth and its atmosphere. Note that radar clutter is not considered as part of this analysis because it almost always is assumed to be a distributed target that can be dealt with separately by the radar signal processor.

- **Clutter model**

A clutter model is used to model the unwanted echoes in a radar system (Figure 6.5). The echoes are typically returned from ground, sea, rain, animals/insects, chaff, and atmospheric turbulence, and can cause serious performance issues with radar systems. Clutter can be best modeled using a statistical approach that combines the probability density function (PDF) for clutter amplitude and clutter power spectrum density (PSD). The PDF is used for the time-domain statistical property description, while the PSD is used for the frequency-domain description. Both are suitable for describing the effects of the radar environment. The K-clutter model is another important statistical model and is used for sea and ground clutters.

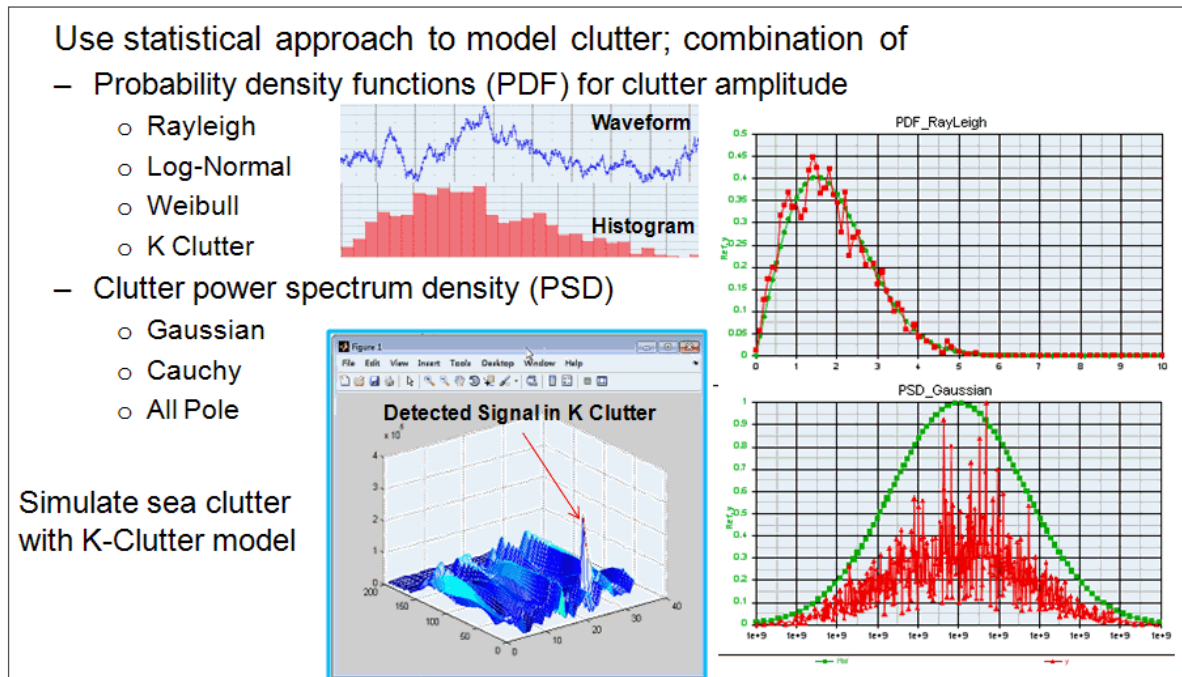

Figure 6.5. Shown here is a clutter model.

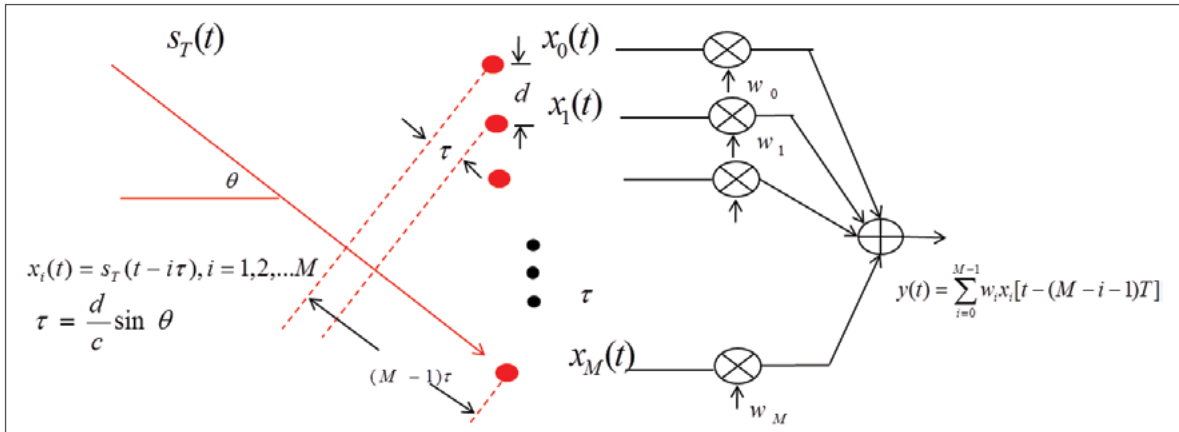

Figure 6.7. A beamformer model is shown here.

Antenna Pattern Measurements

Both 3D and 2D antenna pattern measurements can be implemented for array systems.

In the design in Figure 6.7, a signal source is followed by a Tx beamformer to specify a 16-x-16 rectangular array with beam direction at Phi=0 and Theta=0. Through a T/R module, a Tx array antenna model is used to send out the defined signals. Then, an ideal transmitter is used, followed by a sink to collect the transmission data. Next, post processing is used in an equation block and MATLAB 3D plots are used in 3D and 2D (Figure 6.8).

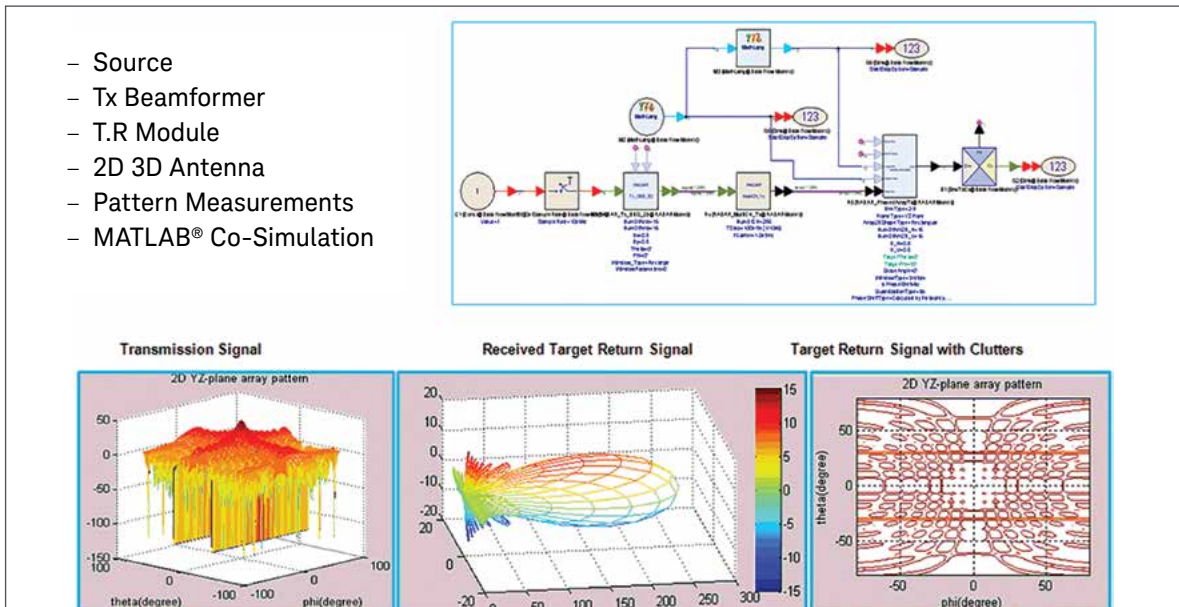

Figure 6.8. An example of array antenna pattern measurements.

RF Co-Simulation

A radar cross-domain simulation example for the Tx design and verification is shown in Figure 6.9. The source and measurement are in the system-level data flow. The Tx is linked to the circuits with X-parameters using SystemVue's Co-Sim capability. Waveform Composer is used for a Tx source in which a frequency hopping radar source with different frequencies at 1.3, 1.5 and 1.7GHz is created. Using this setup, the engineer can design and verify a complex RF transmitter with frequency hopping signals.

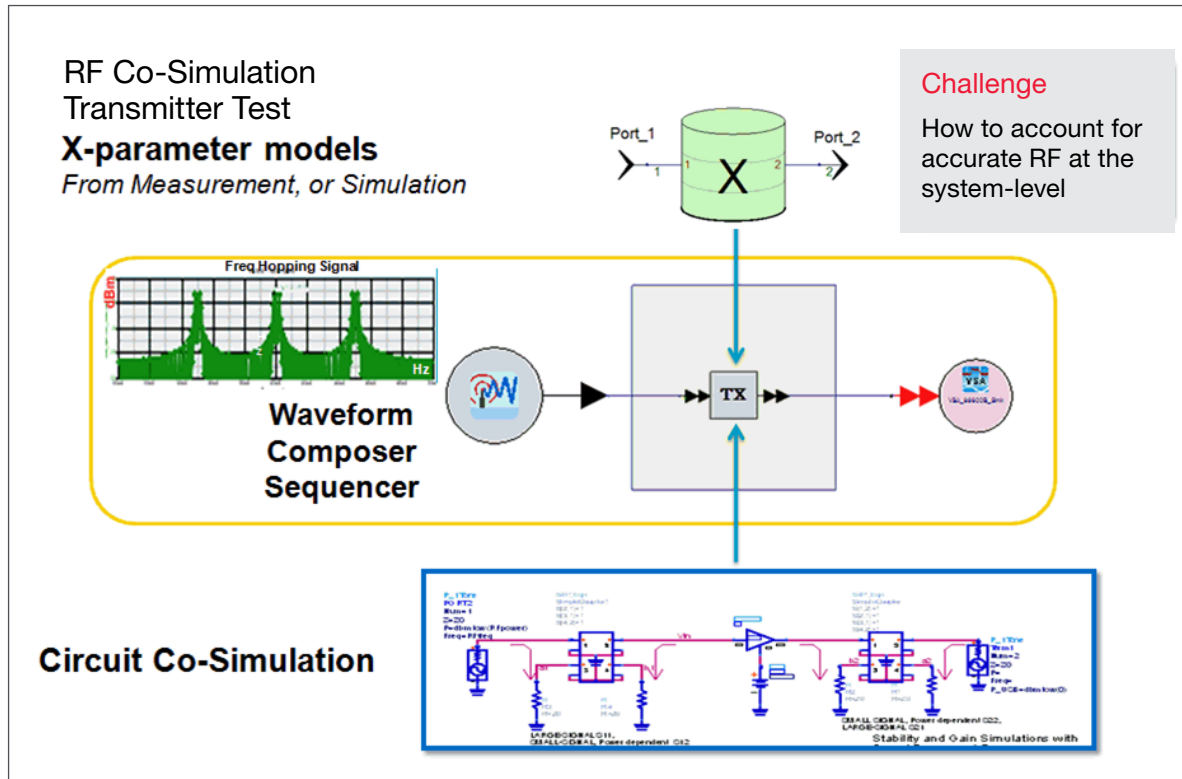

Figure 6.9. An example of a RF co-simulation transmitter test.

System Simulation Example Using SystemVue

As an example, a phased-array radar designed in SystemVue is shown in Figure 6.10. The design includes an LFM source, Tx beamformer with T/R modules, array antenna with 16 sub-arrays, radar moving target RCS, radar environments (e.g., clutter and jamming/Interference), Rx receiver, Rx beamformer with T/R modules, and receiver signal processor for pulse compression, MTI, and MTD measurements.

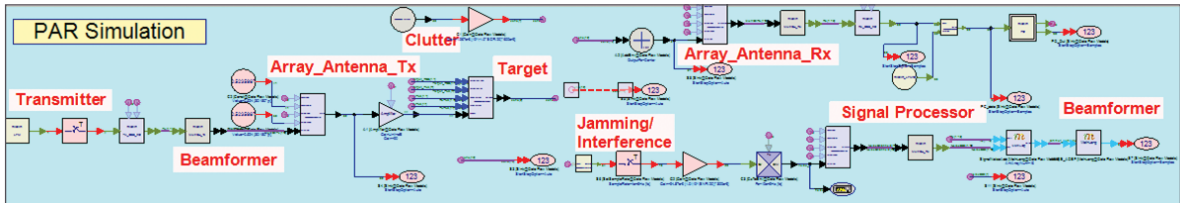

Figure 6.10. A phased-array radar simulation example.

After running the simulation, the following waveforms can be observed, as shown in Figure 6.11: figure A is an LFM transmission signal, figure B is the received signal (return target plus clutter) hidden in strong clutter and noise, and figure C is the return target with pulse compression hidden; MTI and MTD are recovered and detected. In figure D, the return target through the signal processor (MTI and MTD) is recovered.

In Figure 6.12, two 3D displays are plotted to show the detected signal in the Range-Doppler plane. The first one shows the detected signal without any signal processing, while the second shows the signal with signal processing.

Using the template in Figure 6.10, the user can quickly put together a phased-array radar system for algorithm design, with a phased-array antenna and advanced signal processing. A cross-domain architecture is also supported, and complex environments and advanced measurements are considered.

This allows the user to insert a custom algorithm and re-use their Intellectual Property (IP) for design and validation.

The template is easy to use because the design schematic, measurement results, and estimated parameters are all shown at the top level of the screen, eliminating the need for the engineer to have to track down results from various places. Key specified parameters can be easily modified using sliders at the same top level. The engineer simply makes one click and the results populate the screen, including a 3D plot, measurements, and parameter estimations.

To create a custom design, engineers need not start from scratch. Instead, the example design in Figure 6.10 can be used as a template. The user simply modifies the template by changing parameters and replacing models with existing models in the radar library or by importing custom models into the design.

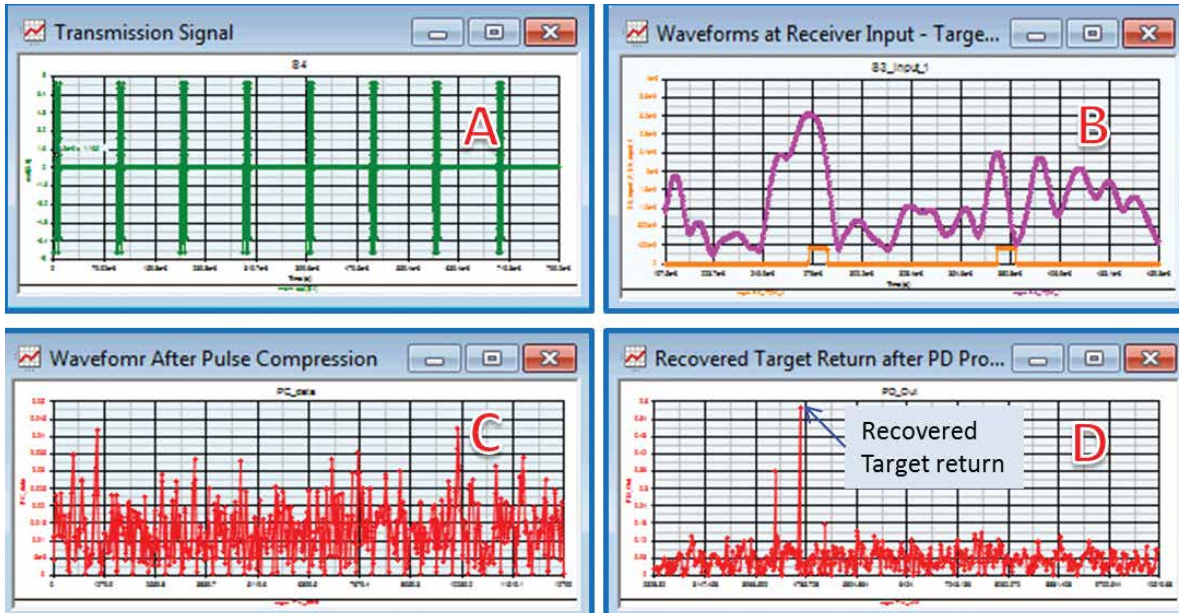

Figure 6.11. The phased-array radar simulation results.

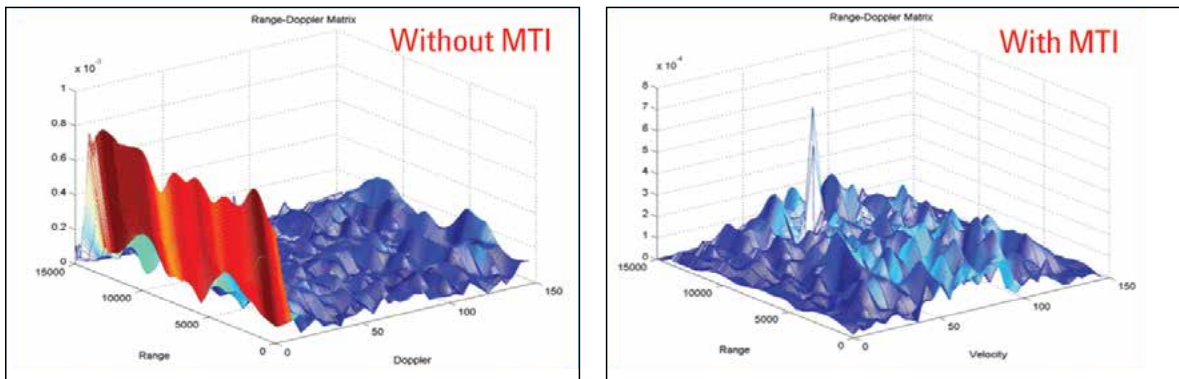

Figure 6.12. The phased-array radar simulation results in a 3D plot.

Regardless of the radar system-level test solution utilized, core software is needed to integrate all test software and hardware and to automate the test.

SystemVue integrates all test instruments together as a test system that provides complex radar test signals with environment scenarios to the Device-Under-Test (DUT), to capture DUT outputs and then synchronize signals, post-processing the result to extract more information and obtain more advanced measurements, such as detection rate, false alarm rate, and imaging analysis. Without integration and synchronization, each instrument would function on its own, making it impossible to perform complex tests.

Besides the single-channel test, multi-channel test for phased array and MIMO radar is possible using SystemVue's signal downloader to a Vector Signal Generator (VSG) or multichannel VSG like the M9381A for a MIMO source. A VSA link to signal analyzers/scopes like the M9703 can be used for the MIMO receiver test. The basic test system structure is shown in Figure 6.13.

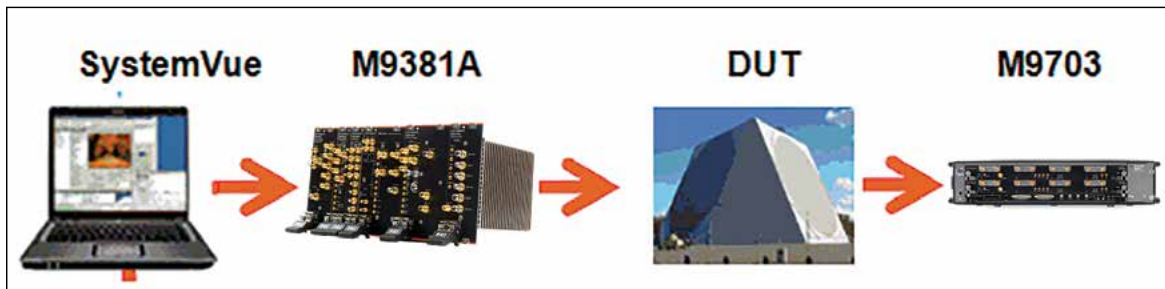
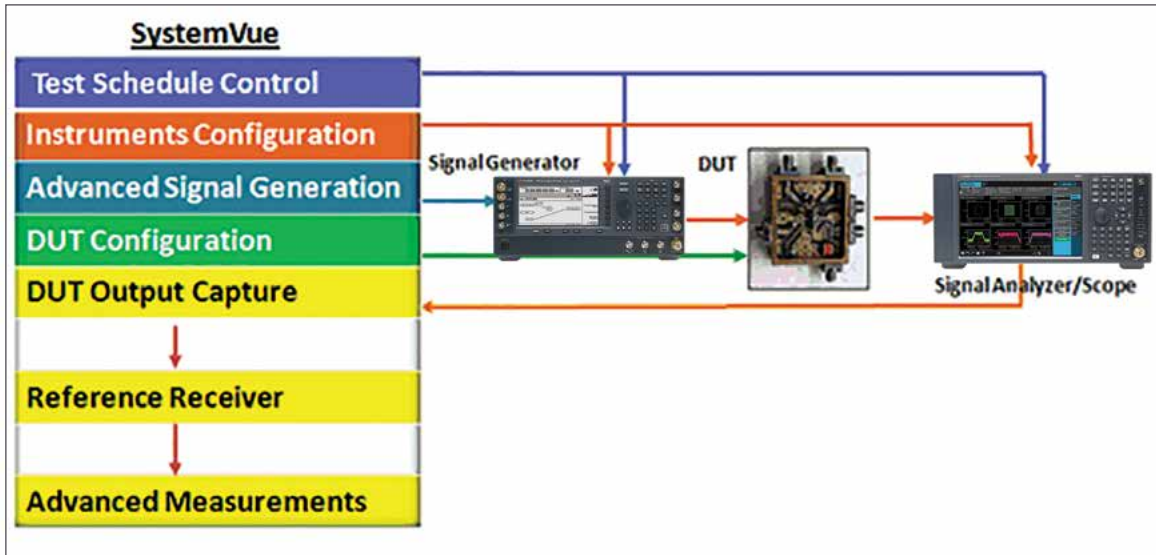

Figure 6.13. Shown here is an integrated test system using SystemVue.

Developing a phased-array radar system is challenging, especially when it involves an AESA device. In this case, the engineer requires a much more integrated solution with a wide breadth of functionality. Use of a platform solution that relies on simulation as its foundation now offers engineers an effective strategy for attacking the challenges they face when designing, verifying, and testing phased-array systems. This approach not only reduces design cycles but also significantly reduces cost.

SystemVue is a prime example of a platform solution. There are several key benefits to using it to design and test phased-array systems. For example, trade-off analysis can be used to significantly reduce cost. Adaptive algorithms can be used to fix amplitude/phase errors for calibration purposes. SystemVue also provides emulation environments that account for clutter and Interference. Lastly, validation can be performed based on measured antenna patterns, Tx measurements such as waveform, spectrum, time-side-lobes; and Rx measurements such as detection rate and false alarm rate, which helps reduce the design cycle.

Using the design templates provided in the model based SystemVue platform users can:

- Quickly put together a new system-level proposal by creating, with a higher level of confidence, an integrated RF and DSP architecture design.
- Easily integrate IP written in different languages (e.g., C++, MATLAB, ADS, and HDL) at the system level for a radar/Electronic Warfare (EW) system.
- Easily create complex radar/EW scenarios and verify systems with environment scenarios (e.g., clutter, jamming/deception, interference, and RCS) to meet complex system specifications and perform virtual flight testing to reduce the high cost of the field test.
- Utilize an integrated test system.

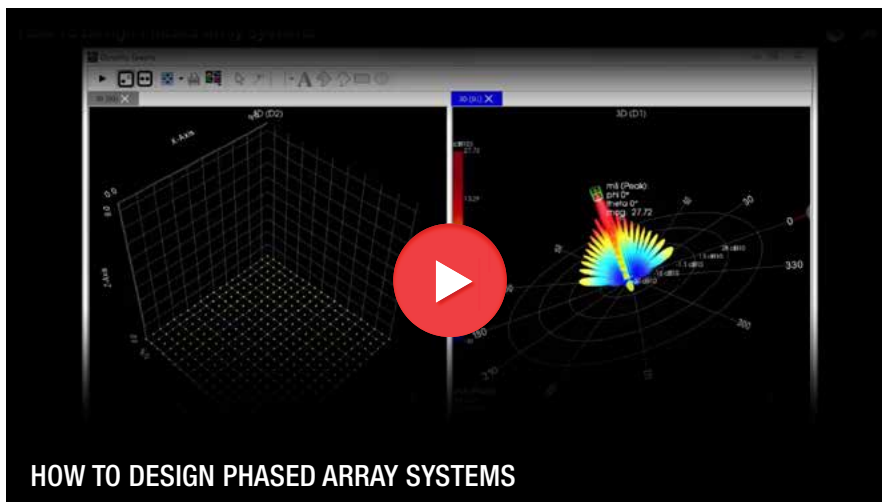

<https://www.keysight.com/see/radar-ew-system-design>



Chapter 7 Generating Signals for Radar and EW Design and Verification

Modern radar systems use more complex signal formats working in wide or ultra-wide bandwidths, and operating in different frequencies (e.g., X, Ku, and Ka bands). As we have seen in the previous chapters, they also use advanced digital signal processing techniques to disguise their operation and overcome strong clutter and jamming in their environment. Addressing this complexity requires a generation of realistic test signals and system-level scenarios that can be used to create and verify the radar signal processing algorithms. While dedicated hardware simulators and field testing are typically used to generate these test signals, both are costly, time-consuming, and apply later in the design process. This chapter presents a less expensive option for generating test signals early in system development. This approach to system-level design and verification uses the Keysight's PathWave System Design (SystemVue) environment, a Radar Model Library, and commercial off-the-shelf test equipment for the generation of continual and pulse radar waveforms, for both algorithm and hardware verification.

Design Problem

Radar signal processing algorithms play a critical role in advanced radar, especially high-performance multi-mode systems. Radar designers require custom reference waveforms with precise amounts of impairment and field conditions when testing or verifying components (both baseband and RF). The signal scenarios are used both for troubleshooting and block-level diagnostics, as well as for initial platform integration and validation.

Unfortunately, signal processing algorithm creation is complicated, with all resulting algorithms needing to be verified in the complex external environment. Greater interaction between algorithms and signal sources provides a realistic radar environment that allows early maturity and confidence in the radar system. Creating the advanced algorithms, therefore, requires the availability of a sufficient set of models for the various radar elements and functions, including signal generation, transmission, antenna, T/R switching, clutter, noise, jamming, receiving, signal processing, and measurements.

Common Approaches to Radar System Design

The two methods commonly employed by radar designers to generate the required signals for algorithm creation are accelerated, dedicated hardware simulation, and direct field testing.

Hardware simulation

Scenario-based verification is typically performed using expensive, high-end hardware simulators that create real-time scenarios of realistic fidelity. Unfortunately, such simulators are not available early enough in the design process (during the algorithm stage before hardware implementation), to provide meaningful insight for the algorithm developer. They also don't integrate well with model-based design practices or provide the level of scripting needed in early development for low-level, block-level verification. Because simulation takes place later in the design cycle, making design changes at this stage can be both costly and time-consuming. Design engineers can benefit from earlier algorithmic validation of their key ideas.

Field testing

Another way to generate the required signals is to physically go into the field to make environmental measurements of the radar hardware operating under realistic conditions. While there are many reasons for utilizing this approach, because it comes late in the design process it rarely connects to the original algorithmic development environment. In addition, this method is costly, sometimes inconvenient, and cumbersome.

A More Practical, Less Expensive Option

For early development, a robust and inexpensive alternative uses a convenient software simulation-based radar library to generate the reference waveforms needed for radar signal processing algorithm development. Early access to these signals enables the design of superior system architectures and facilitates early hardware verification at different layers of abstraction, as the model-based design matures.

The Keysight radar library application

As can be seen from Table 7.1, the Keysight W4521 Aerospace / Defense Library is an advanced simulation block set of over 35 highly parameterized primitive blocks and higher-level reference designs. It can be used for modeling different types of radar systems, creating radar signal processing algorithms, evaluating the system's performance, and providing proof-of-concept designs. The block set and its example workspaces serve as algorithmic and architectural reference designs to verify radar performance under different conditions. These include target and radar cross section (RCS) scenarios, clutter conditions, jamming (intentional), and environmental interference, and the effect of various receiver algorithms. It is ideal for radar designers who need to generate precise signals for algorithm and hardware verification or study the performance of their radar systems under various conditions.

Signal sources	LFM – Linear FM wave generator NLFM – Nonlinear FM wave generator BarkerCode – Poly-phase code wave generator FrankCode – Frank code wave generator ZCCode – Zadoff–Chu code wave generator MatchedSrc – Generates the matched source signal for pulse compression
Signal processing	Detector – Video signal detector FFT – Complex fast Fourier transform PC – Pulse compression processing PD – Pulse Doppler processing MTI – Moving target indication MTD – Moving target detection CFAR – Constant false-alarm rate process Window – Windowing for sidelobe control
Transmitter	CICInterp – Interpolation with cascaded CIC filters DUC – Digital up-converter, baseband to intermediate frequency UpSample – Up sampler with poly-phase filter Tx – Transmitter front end
Receiver	CICDecimate – decimation with cascaded CIC filters DDC – Digital down-converter, intermediate frequency to baseband DownSample – Down sampler with poly-phase filter Rx – Receiver front end
Environment	RCS – Radar cross-section modeling Target – Target modeling, including RCS, Doppler effect, delay, attenuation Clutter – Clutter modeling AntennaTx Ant – Transmitter antenna Rx Ant – Receiver antenna
Measurement	Pd Measurement – Detection probability estimation Pf Measurement – False-alarm rate estimation

Table 7.1. The W4521 radar model library block list

The W4521 works within the SystemVue system-level design environment. This is an open modeling environment focused on physical-layer baseband/RF architectures that replace general-purpose digital, analog, and math environments, and co-simulates with HDL for embedded hardware design flows. Together SystemVue and the W4521 create a system-level platform for design and verification that meets the requirements for signal processing algorithm creation (Figure 7.2).

Generate waveforms - Return signals with clutters + jamming

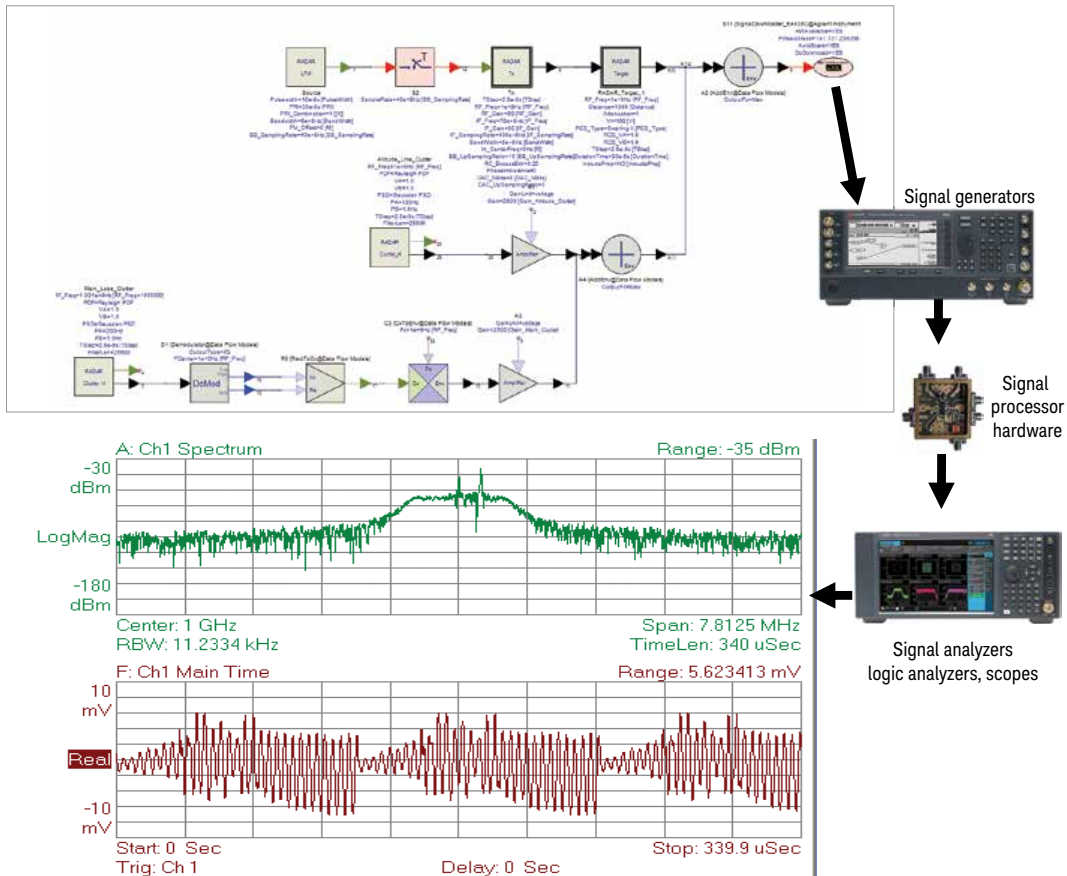
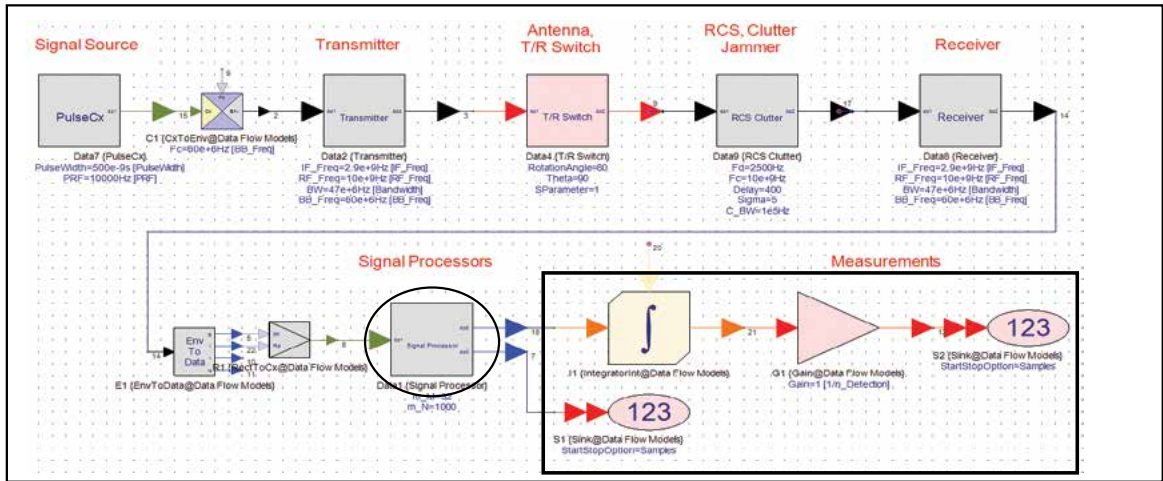

Figure 7.2. The W4521 Aerospace/Defense Library and SystemVue system platform.

The platform provides a user-friendly algorithm modeling and debug environment that supports a variety of languages (e.g., C++ and math language), as well as an algorithm design and verification environment for signal generation and performance measurements (Figures 7.3 and 7.4). From the block diagram in Figure 7.3, the main models include signal source, transmitter, antenna, T/R switch, RCS, clutter, jammer, receiver, signal processors, and measurements. SystemVue enables the creation of new and customized algorithms for the specific applications of the radar system under design. Many of the available sub-libraries are listed.



Tx waveform library	T/R component	Antenna library	Radar environment	Radar signal processing
<ul style="list-style-type: none"> - Radar pulse generator - Coherent signal generator for single or multiple channel 	<ul style="list-style-type: none"> - DAC - PA - Up converter - Filter - DDS - LNA - Down converter - ADC 	<ul style="list-style-type: none"> - Antenna models - T/R antenna array - Antenna propagation 	<ul style="list-style-type: none"> - Target - Clutter - Jammer - Interference 	<ul style="list-style-type: none"> - Digital pulse compression - Moving Target Indication (MTI) - Moving Target Detection (MTD) - Constant False Alarm Rate (CFAR) - Digital beamformer - Space-Time Adaptive Processing (STAP)

Figure 7.3. SystemVue combined with the optional W4521 Aerospace/Defense Library is a platform for radar system design.

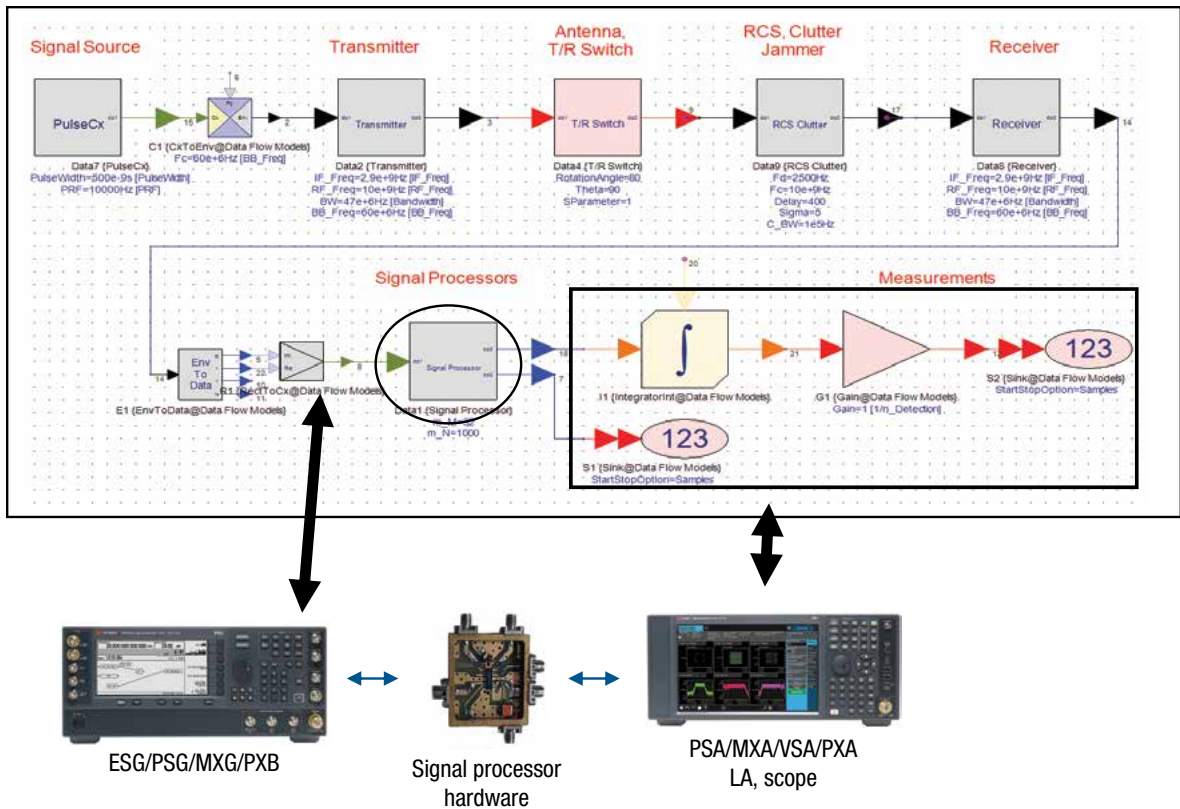

Figure 7.4. A platform for radar verification.

As shown in Figure 7.4, radar components can be connected to instruments and test hardware based on the created algorithm.

To better understand how the W4521 Aerospace/Defense Library and SystemVue platform generate radar test signals, consider the test setup in Figure 7.5. Here, an interface model (Sink) in SystemVue connects to one of the Keysight ESG/PSG/MXG families of vector signal generators. SystemVue generates radar waveforms in simulation that are automatically downloaded at run-time into the instruments for use as RF/IF test signals during hardware testing. Waveforms captured by the vector signal analyzer can then be automatically returned to SystemVue. Acquired waveforms can be further processed in SystemVue.

Effectively, a smart simulation platform (SystemVue with the Aerospace/Defense Library) surrounded by wideband stimulus/response equipment can be used to manually imitate missing hardware blocks, to complete a working radar system. This allows system-level validation to continue at an earlier date, based on partially implemented hardware. As real hardware becomes available, the simulation platform withdraws to function more effectively with the test equipment to provide targeted radar signals for testing. By working early within the radar block diagram, SystemVue serves a variety of R&D needs such as design transitions from concept to working prototype, eventually assisting with hardware testing. This serves an expanded function relative to the Keysight Signal Studio for pulse building software, which is focused specifically on test signal creation using Keysight signal generators, for final hardware validation.

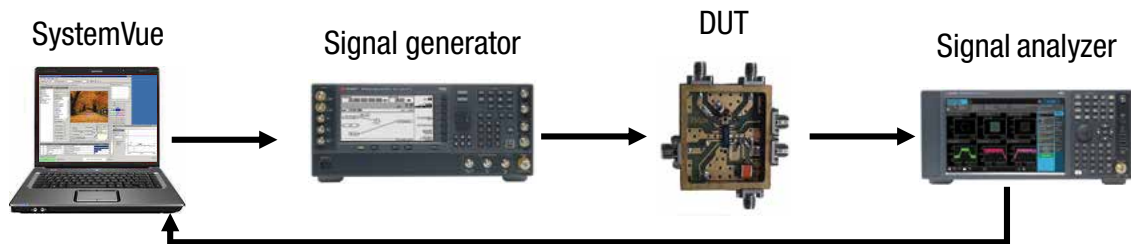

Figure 7.5. Platform for radar test signal generation.

The SystemVue platform provides an interface to a range of test equipment to help verify the implemented hardware (compared to the original pure algorithm). Supported algorithmic reference sources include radar signal generation with RCS, clutter, jamming, and Doppler frequency offset. Supported measurements include waveforms, spectra, detection rate, and false alarm rate (FAR).

Some of the test equipment that can be connected to SystemVue includes signal analyzers, logic analyzers, and scopes (e.g., Keysight's Infiniium 90000 X-Series high-performance oscilloscope).

Radar Component Test Examples

To test radar components in a transmitter and receiver, the W4521 can be used to generate various types of test signals including radar transmission signals such as LFM, NFM, Coded FM, return (RCS) signals, and return signals with clutter. An example of return signals with clutter is shown in Figures 7.6 to 7.9.

Generate waveforms - Radar transmission (LFM) signals

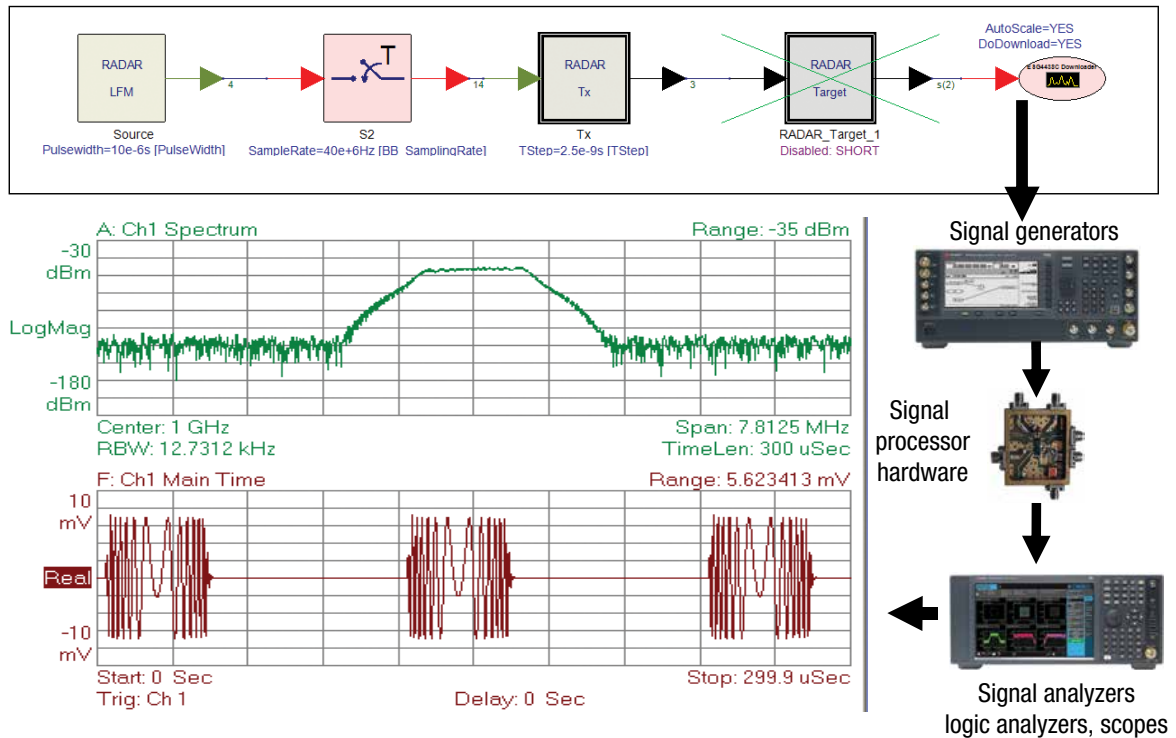

Figure 7.6. This diagram shows how a LFM radar transmission signal can be generated in SystemVue and then downloaded to Keysight's ESG/MSG/PSG vector signal generator. The LFM transmission signal can be used for radar component testing.

Generate waveforms - Return (RCS) signals

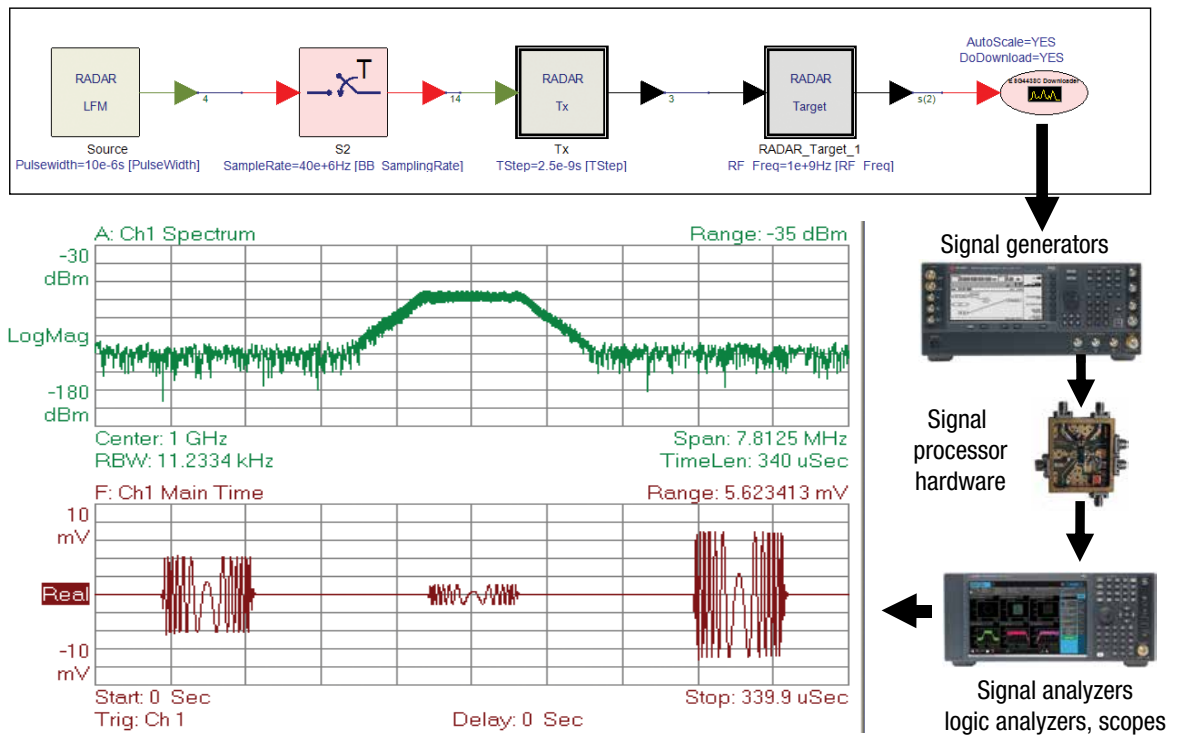

Figure 7.7. This diagram depicts how to generate the radar receiver test signal. Users can use the SystemVue radar Target model to specify target range, velocity, and radar cross-section models. The receiver signal can be used to test radar receiver detection algorithms.

Generate waveforms - Return signals with clutters

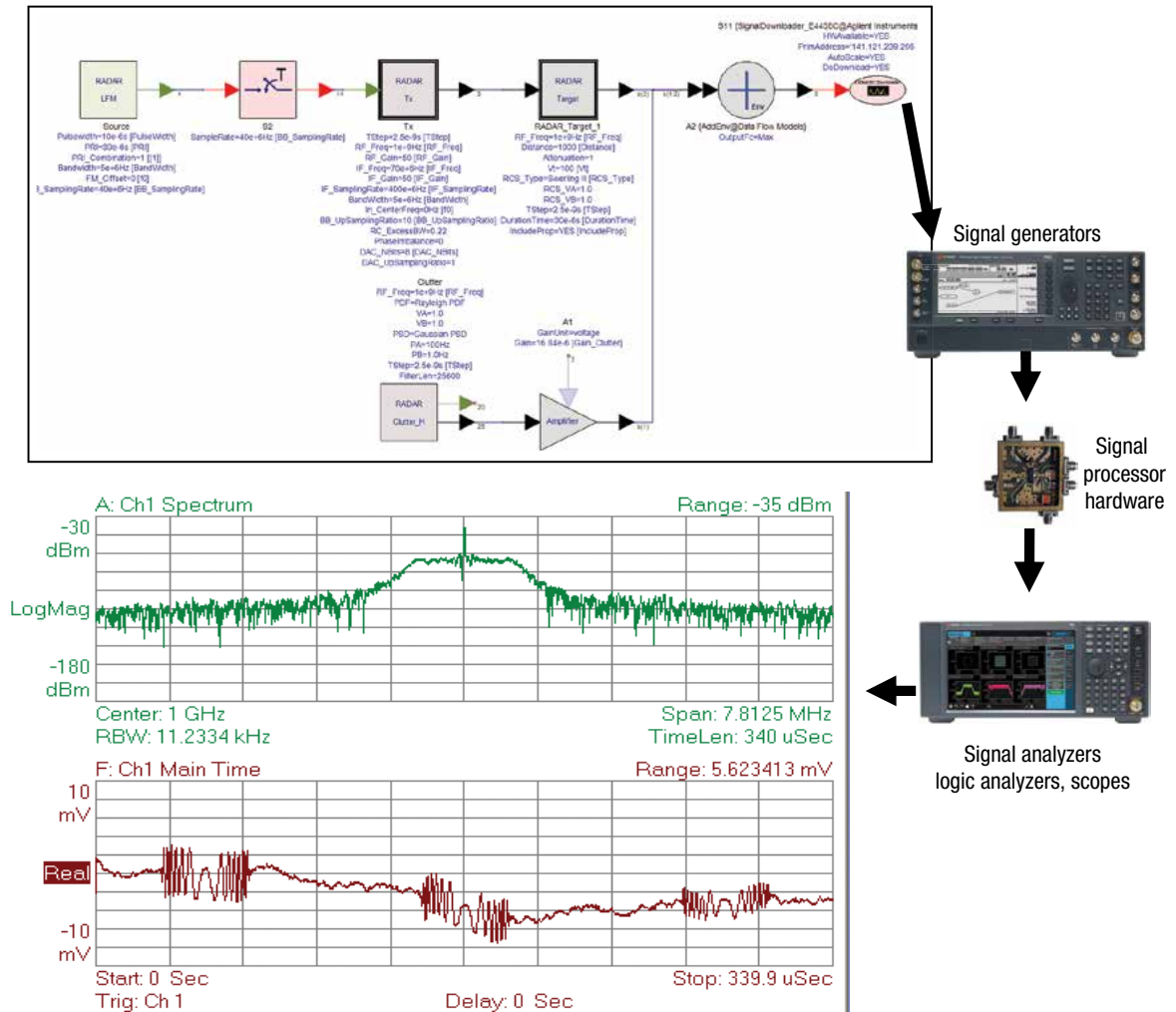

Figure 7.8. The resulting radar received signal with RCS and clutter describes the radar environment details.

Generate waveforms - Return signals with clutters + jamming

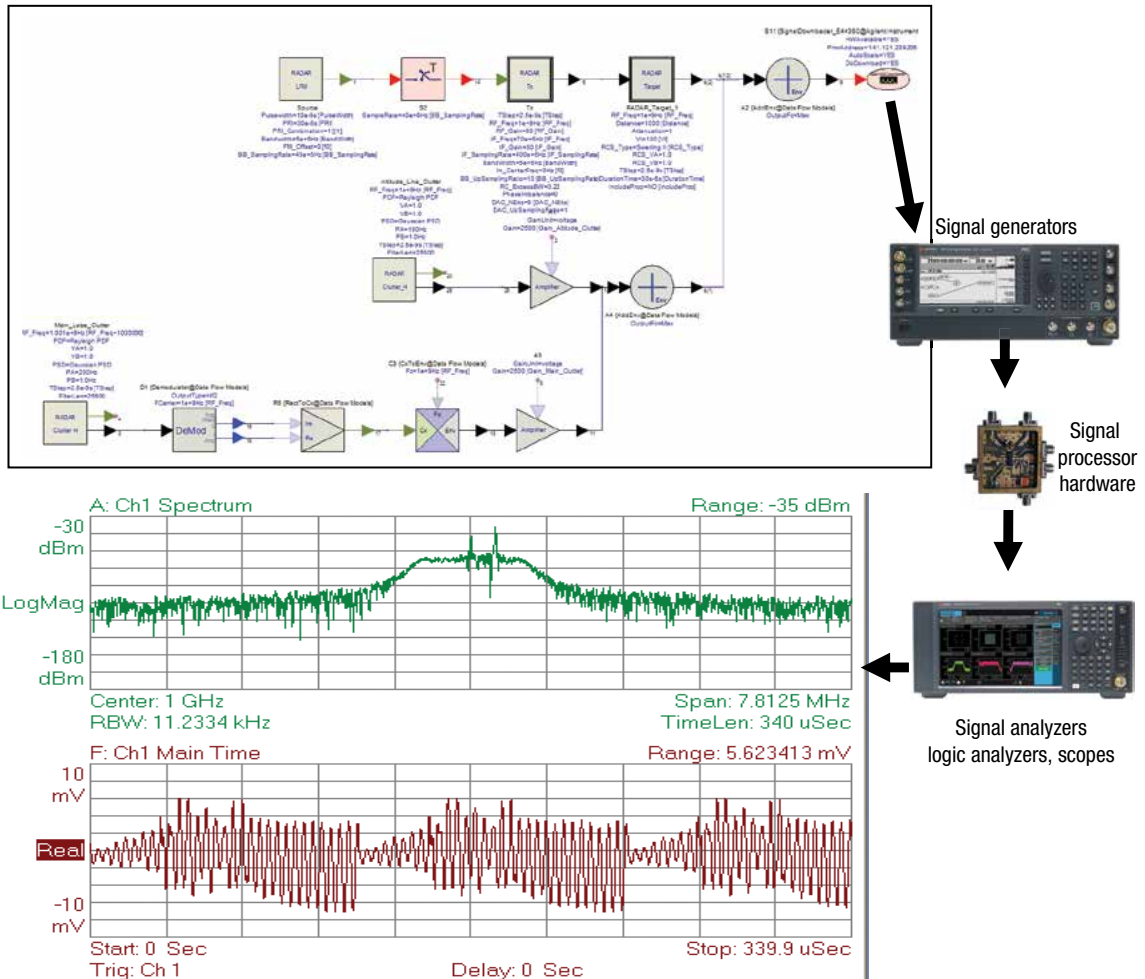

Figure 7.9. Here, the radar received signal has not only RCS and clutter but jamming as well for describing the radar’s complex environment details.

The W4521 can also be used to generate wideband and ultra-wideband signals using the setup shown in Figure 7.10. In this case, SystemVue generates radar baseband I/Q data that is downloaded to the N6030 or N81180 arbitrary waveform generator—a 4.2 GSa/s arbitrary waveform generator with a 12-bit vertical resolution for complex real-world signals. The wideband radar signals formed in the N6030 or N81180 are then sent to the wideband PSG I/Q modulator inputs, which in turn sends RF wideband signals to the DUT to test the RF radar components. Next, the output DUT is captured using the Infiniium 90000 X-Series scope and sent back to the PC for either direct analysis using the VSA software or for further analysis using SystemVue. A generated radar received LFM signal with RCS is shown in Figure 7.11.



Figure 7.10. Test setup for wideband signal generation.

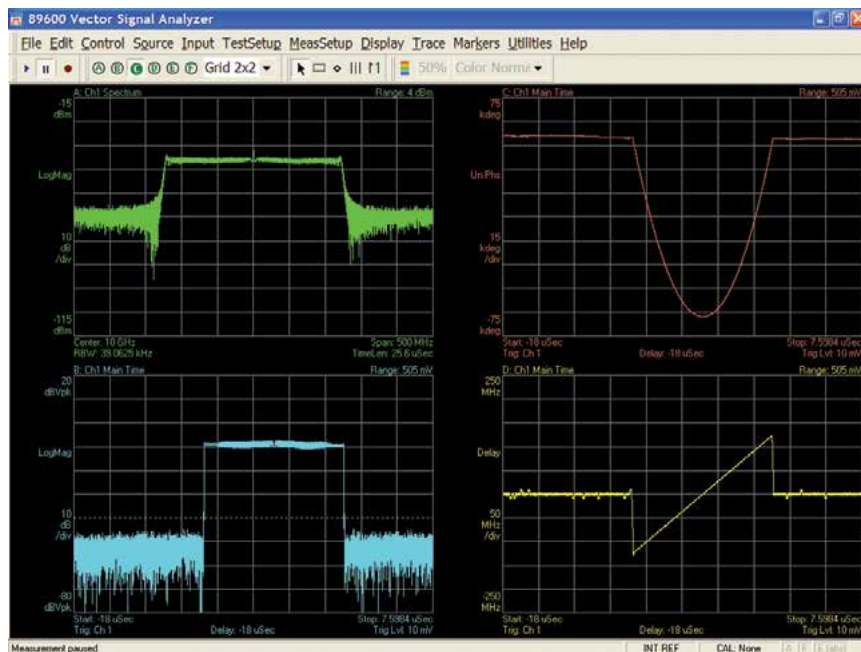
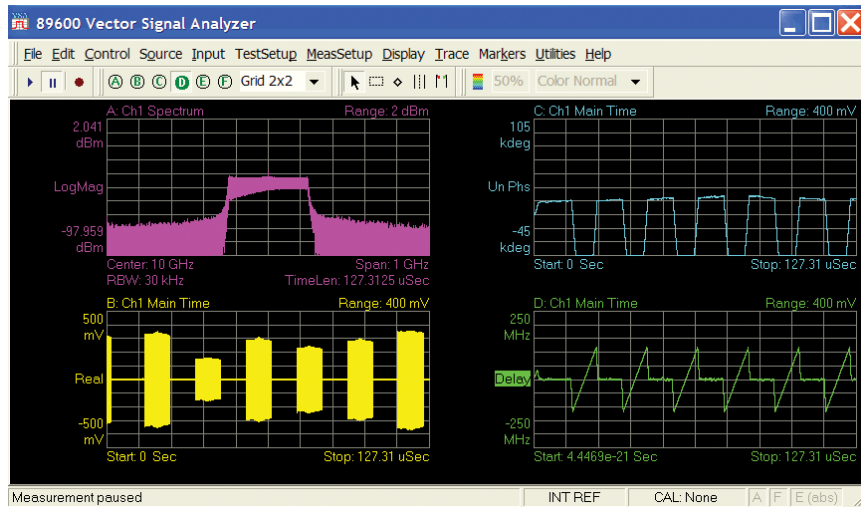

Figure 7.11. This wideband signal (radar received LFM signal with RCS) was generated using SystemVue, the N6030, and PSG. The signal was measured using VSA software.

The complexity of advanced radar systems puts added focus on the radar signal processing algorithms which are critical to their development. Creating these algorithms requires a generation of test signals. While this is typically done using high-performance hardware simulators or range testing, Keysight's W4521 Aerospace/Defense Library offers a more practical, timely, and drastically less expensive alternative. When used with the SystemVue environment, this application provides the basic information needed to create the required test signals earlier in the design cycle, enabling superior system architecture design and facilitating early hardware verification at several layers of abstraction as a design matures. Examples of generated test signals (return signals with clutter and radar received FM signal with RCS) demonstrate the validity of this solution.



Chapter 8 Virtual Flight Testing of Radar System Performance

Taking a system-level approach to a complex design often requires upfront integration and analysis, however, it pays in the long run by focusing time and engineering effort on “winning” design strategies. In this chapter, PathWave System Design (SystemVue) is integrated with the STK software from Analytical Graphics Inc. (AGI, an Ansys company) to take advantage of their respective domain strengths in order to address difficult radar modeling and verification issues.

In addition, the SystemVue Aerospace/Defense library provides radar signal processing/domain IP to render the final details of this particular system and a friendly interface for modeling and test equipment.

Problem Statement: Reducing Dependency on Flight Testing

Flight testing is the ultimate way to evaluate the performance of a radar and EW system. During the actual aircraft flight, data such as Probability of Detection, Signal Strength, and clutter might be gathered. While effective, this approach does pose several challenges. The operational cost of flight testing a radar system using real aircraft can be over \$100,000 per hour (Figure 8.1). Additionally, the results from one flight to the next are not repeatable. Each flight is slightly different and getting enough flights in to be statistically significant is simply too costly.

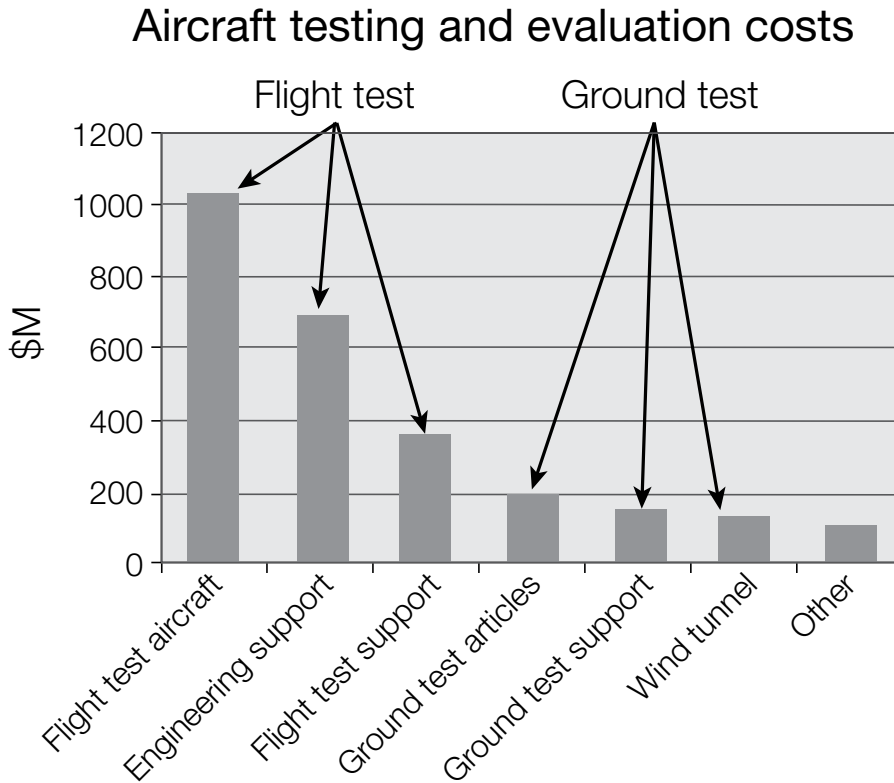

Opportunities for lean thinking in aircraft flight testing and evaluation
Carmen F Carreras-Massachusetts Institute of Technology, June 2012

Figure 8.1. The high cost and time associated with flight testing is an incentive to explore alternative solutions.

While final operational verification may still be necessary for contractual or legal reasons, “virtual flight testing” is a faster, more cost-effective alternative for earlier stages of R&D, such as algorithm and countermeasures development. In a simulation, complex radar systems can be evaluated hundreds of times in an hour, using the same or varied scenarios for each run (flight), and at significantly less cost than a single hour on a flight range. By evaluating realistic flight-testing scenarios before or in place of physical flight testing, engineers can validate electronic warfare algorithms earlier, saving both time and money.

A Virtual Solution

A virtual flight test solution can be created by marrying the capabilities of Keysight's PathWave System Design (SystemVue). SystemVue is electronic-system-level design software that integrates modeling, simulation, reference IP, hardware generation, and measurement links into a single, versatile platform (Figure 8.2). It enables system architects and algorithm developers to innovate the physical layer (PHY) of wireless and aerospace/defense radar and communications systems and provides unique value to RF, DSP, and FPGA/ASIC implementers. The W4521 Aerospace/Defense library provides baseband signal processing reference models for a variety of radar architectures. STK is a physics-based software geometry engine that accurately displays and analyzes land, sea, air, and space assets in real or simulated time. It can include the aircraft flight dynamics, terrain effects, and the aircraft's 3D radar cross section (RCS).

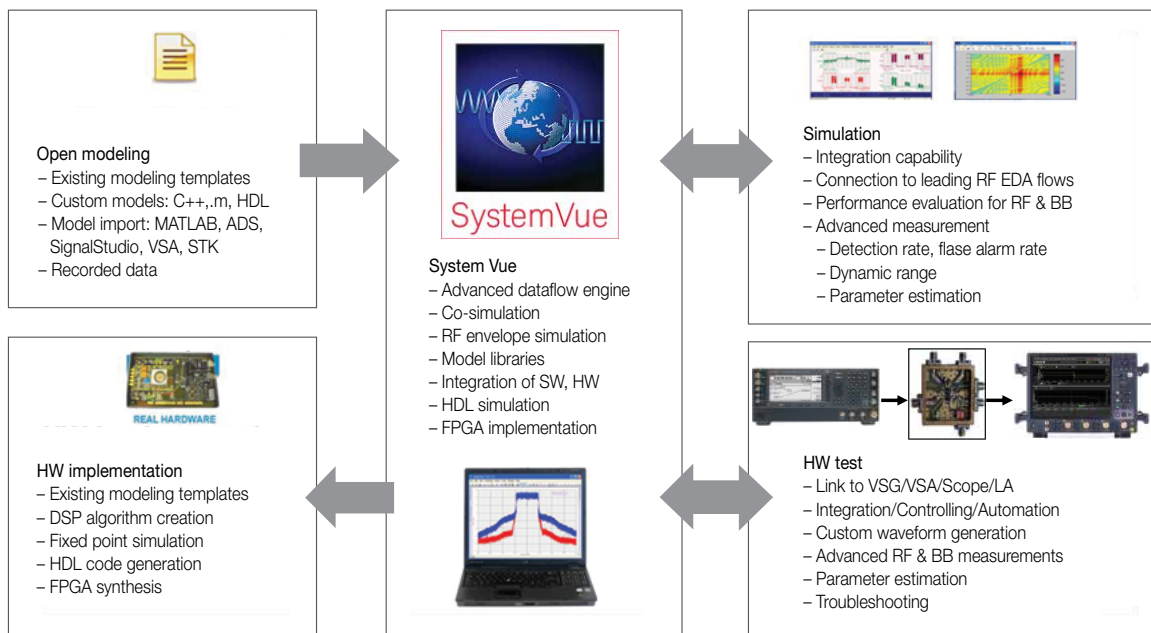

Figure 8.2. With SystemVue, PHY development is enabled across RF and baseband domains and that development can easily transition from algorithms into hardware verification.

The basic STK process is to define a system link scenario with moving transmitter (Tx), receiver (Rx), and interferer objects. The scenario is then analyzed to obtain system metrics as a function of time (e.g., range, propagation loss, RCS, noise bandwidth, and Rx signal strength). Almost everything in STK can be controlled by third-party tools. However, the software has no inherent ability to process signals from radar/communications applications through the dynamic environment link. Linking STK with SystemVue allows arbitrary Tx/Rx radar/communications systems to be modeled with the STK dynamic environment link characteristics. During virtual flight testing, SystemVue models the radar system including waveform

generation, Tx and Rx non-ideal behavior, DSP and RF processing, and radar post-processing, while STK models the flight scenario and signal path characteristics (e.g., path loss, Doppler, aircraft aspect RCS, and atmospheric losses).

Virtual Flight Testing Example

To gain a clearer understanding of the interface between SystemVue and STK, and its application to virtual flight testing, consider the 3D STK simulation scenario of a fighter sortie (Figure 8.3). In this example, assume the sortie starts at 10,000 feet and is detected by radar. To try to get below the radar, it dives down to do low-level terrain-following, sometimes successfully, sometimes not. The same run can be repeated hundreds of times, with different radar or electronic countermeasure assets in place as modeled by SystemVue, along with the terrain, aircraft (including 3D RCS), and the radar site characteristics as modeled in STK.

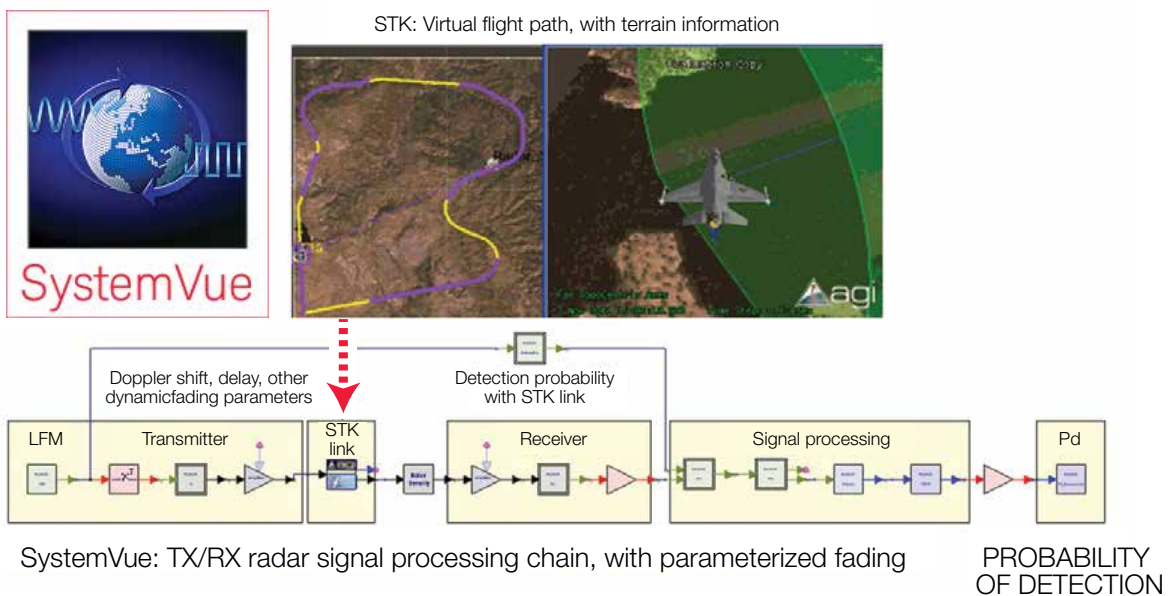

Figure 8.3. One application of the interface between SystemVue and STK is the ability to do virtual flight testing of radar systems, including DSP, RF impairments, jamming, and interference as an aircraft encounters targets and clutter along a virtual flight plan.

As shown in Figure 8.4, a custom user interface can be easily implemented within SystemVue to make repetitive tasks and complex measurements much easier to manage. Here, SystemVue creates a radar waveform and passes it through a transmit chain to multiple target models (including jamming and added clutter). The resultant RF waveform can then be input into an arbitrary waveform generator and introduced into a receiver for performance validation. SystemVue also has tight integration with MATLAB, C++, and HDL simulators so existing radar algorithms can also be integrated into the scenario. Measurement-based data, such as a jammer profile or measured interference, could also be added into the simulation directly through Keysight test equipment links.

Virtual Flight Testing Example

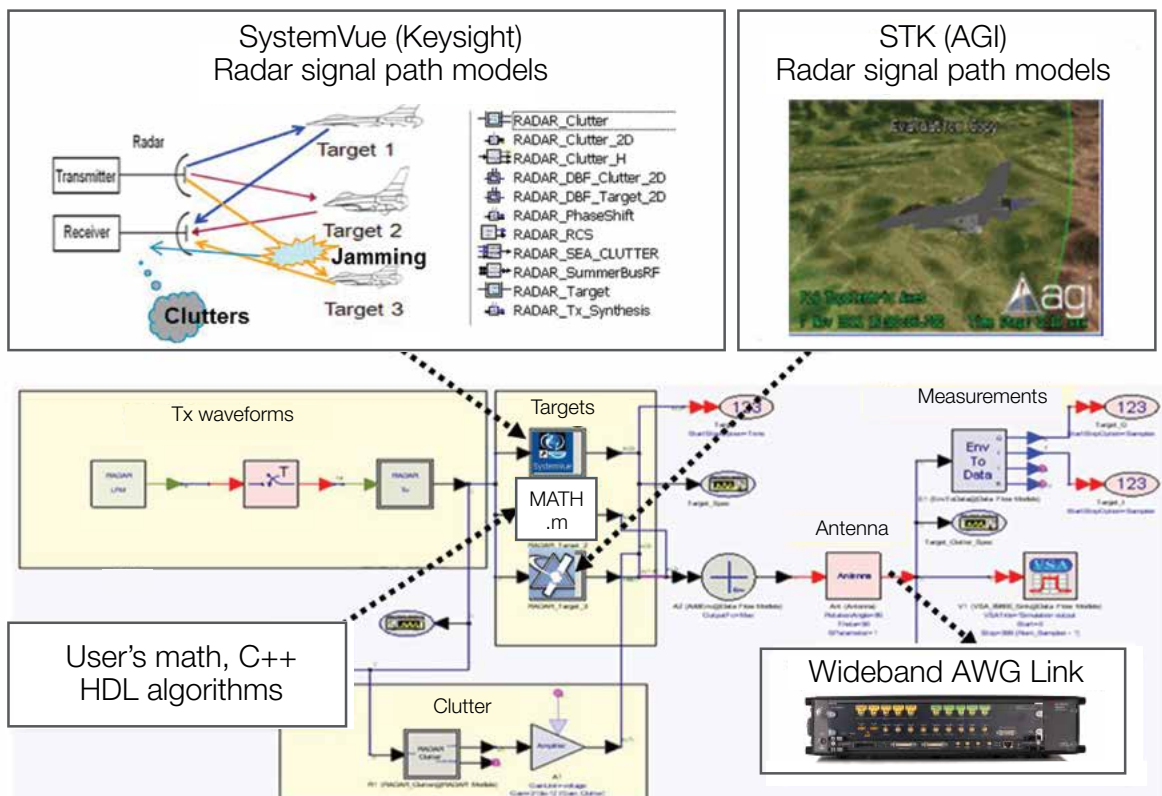

Figure 8.4. In this multiple target signal emulation example, test entry comes from a custom user interface with hardware text flavor. The user does not have to open a simulation schematic. This approach integrates both signal generation and signal analysis.

Flexible API Enables Custom Applications and Measurements

Linking the SystemVue and STK solutions allows for quick and repeatable validation of multiple realistic radar system scenarios. These scenarios can be evaluated in place of physical flight testing or, in cases where operational flight testing is unavoidable, they can be evaluated beforehand to ensure they make the most effective use of resources.

Some applications of virtual testing:

- Evaluate new jamming techniques or threats
- Inject multiple dynamic emitters and targets into your scenarios
- Allow various types of jamming based on a defined set of criteria for dynamic operation
- Modeling and evaluation of cross-domain effects, such as automatic gain control
- Include unintended interference from commercial wireless networks

The interface presented in this chapter started with the commercially available SystemVue and STK environments and then used their application programming interfaces (APIs) to link them together.

When it comes to testing radar system performance, extensive flight testing using physical aircraft is a prohibitively expensive and time-consuming proposition. Virtual flight testing, made possible by the flexible interfaces between the SystemVue and STK software tools, now offers an economical alternative for R&D validation. This allows measurement hardened algorithms to be deployed quickly, and a minimum of true operational testing to be done with greater confidence, to save costs. By closing the loop between lab-based virtual testing (simulation and test equipment) and operational testing, virtual testing can be made even more effective.

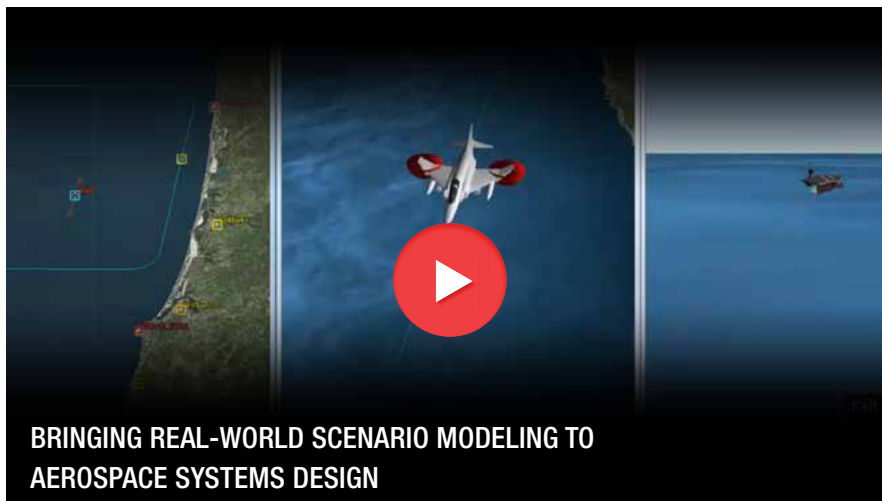

<https://www.keysight.com/see/radar-ew-system-design>

Section 3

RF Component Test and Verification



Introduction

As radar and EW systems become ever more sophisticated, their demanding performance requirements flow downstream to produce challenging specifications at the component level, with a need to characterize at higher frequencies, wider bandwidths, lower noise levels, and with complex signals.

This section addresses the measurement fundamentals of Distortion, Noise, Phase Noise, and S-parameters. We also cover the “Active-Hot” characterization of nonlinear devices such as amplifiers, introducing the concept of X-parameters and the benefits. Finally, we look at characterizing materials that may plan to be used in radomes or for RF absorption, in and around your radar and EW system.



<https://www.keysight.com/see/radar-ew-component-test>



Chapter 9 Figures of Merit Aid Amplifier Distortion Assessment

Distortion not only degrades transmitter performance but also interferes with other receivers. There are two major types of nonlinear distortion measurements — harmonic and intermodulation distortion. Furthermore, no system offers unlimited gain and it is important to understand the compression characteristics of amplifiers in particular, where the saturation point of the output is an important figure of merit.

Harmonic Distortion

The amplitude transfer characteristics of a circuit or device cannot precisely track the input signal. The amplitude shifts generate higher frequency components at integer multiples of the input signal.

Using a continuous wave (CW) tone as an input signal and measuring the output signal with a signal analyzer is the most straightforward method for measuring harmonic distortion; see Figure 9.1. A DUT might be an RF amplifier or mixer.

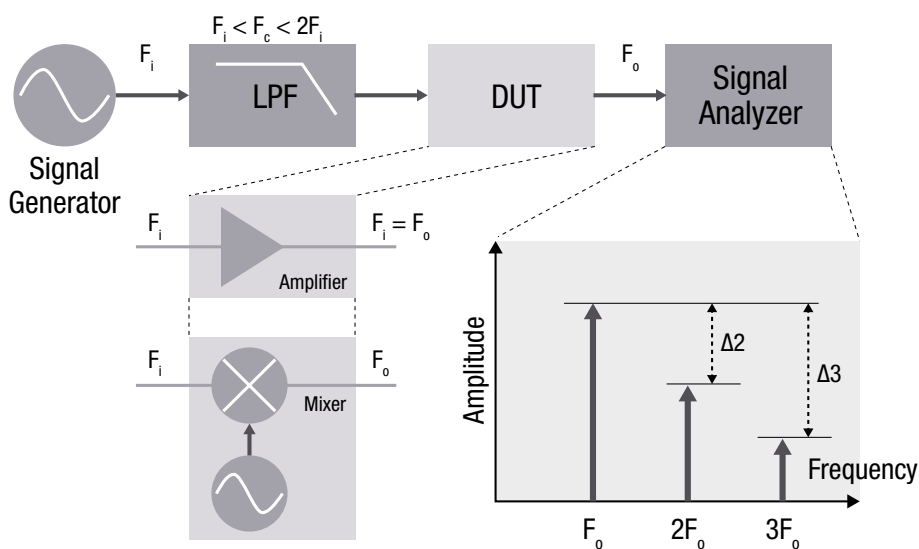

Figure 9.1. Harmonic distortion measurement setup

The signal analyzer sets to zero-span, which enables a time-domain power measurement to measure the power level at the fundamental and harmonic frequencies as shown to the right of Figure 9.2. For a higher-order harmonics measurement, you can choose a higher dynamic range signal analyzer.



Figure 9.2. Harmonics measurement with Keysight signal analyzer

Third-Order Intermodulation

Two-tone, third-order intermodulation (TOI) distortion is a common test for RF distortion measurements. When two or more signals are present in a nonlinear system, they can interact and create additional components at the sum and difference frequencies of the original frequencies and at sums and differences of multiples of those frequencies. Figure 9.3 below shows the two-tone third-order Intermodulation measurement setup. The device under test could be an amplifier or a mixer.

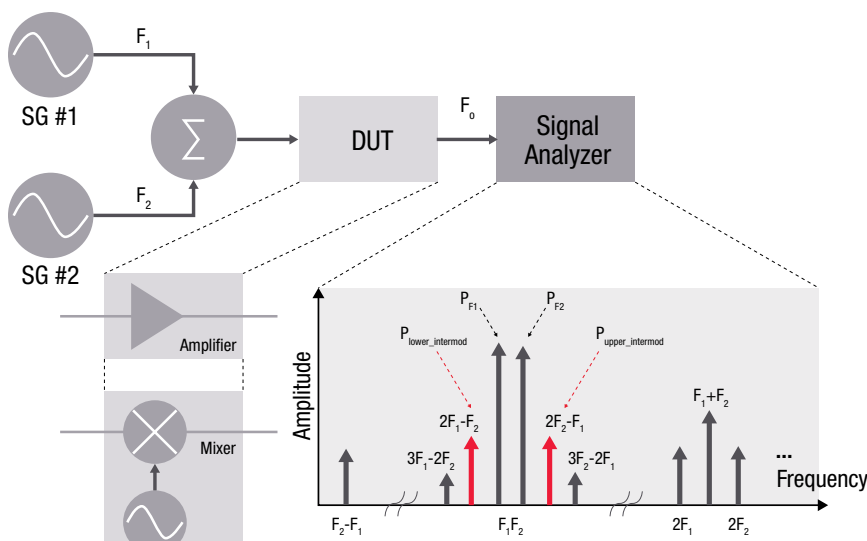

Figure 9.3. Two-tone intermodulation distortion measurement setup

F_1 (lower tone) and F_2 (upper tone) are frequencies of the two test tones from two signal generators. The two tones injected into the system must be free from any third-order products. The third-order distortion products occur at frequencies $2F_1 - F_2$ and $2F_2 - F_1$ (red notations), which are the closest distortion products to the original two test tones. Removing the closest distortion products with filtering is difficult. In a communication system, the distortion products can be interfering signals to the adjacent channels.

The definition of TOI level:

$$TOI_{\text{lower}} \text{ (dBm)} = P_{F_2}/2 + P_{F_1} - P_{\text{lower_intermod}}/2$$

$$TOI_{\text{upper}} \text{ (dBm)} = P_{F_1}/2 + P_{F_2} - P_{\text{upper_intermod}}/2$$

For test efficiency, a vector signal generator alone can be used to generate two test tones using the internal baseband generator to save costs. Keysight offers an advanced correction routine that can suppress distortion products generated by the signal generator itself or an external pre-amplifier. Swept IMD measurement of amplifiers and frequency converters can also be performed using a VNA with an internal combiner and two internal signal generators. Wide receiver dynamic range and high-quality signal sources minimize the measurement errors found in traditional setups.

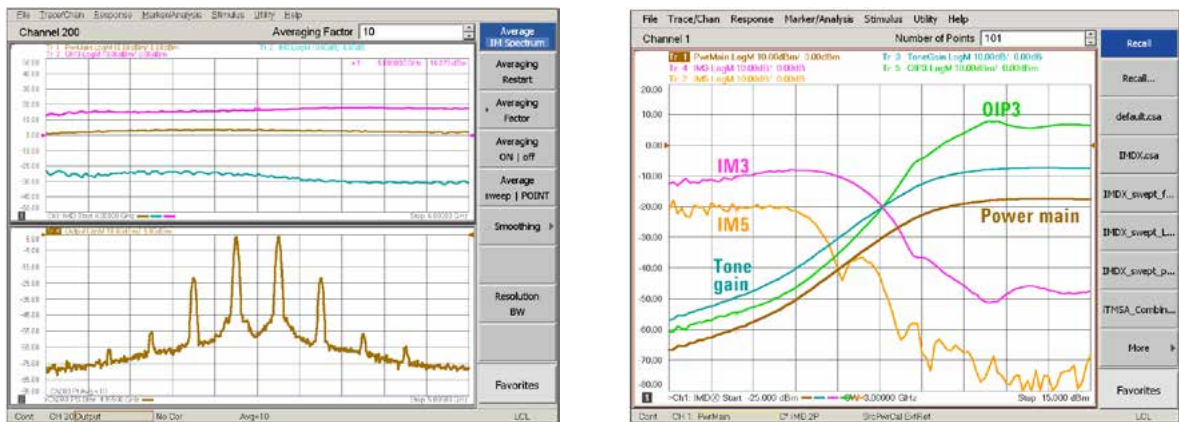

Figure 9.4. PNA-X with S93087B IMD measurement simplifies setup and provides guided calibration.

A third RF source can be added to the 4-port PNA with the same low-phase noise performance as the two internal RF sources. You can use it as the local source of the DUT for two-tone frequency converter measurements or two-stage frequency converter measurements. It eliminates the need for an external signal generator. You can also use it as an independent analog signal generator. For example, it can be used as the reference signal for a DUT that requires the external reference clock signal, and as the reference signal of another measurement instrument.

The 4-port PNA-X can be equipped with extremely low phase noise performance on all internal signal generators making it ideal for IMD measurements where the two-tone stimulus signals must be close to each other.

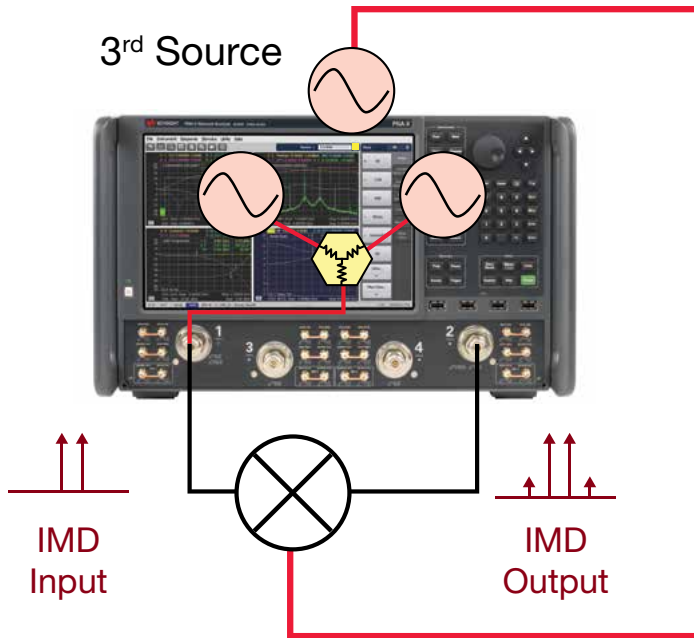

Figure 9.5. Two-tone IMD mixer measurement utilizing three high-performance analog signal generators built into the 4-port PNA-X

Compression

The most common measurement of amplifier compression is the 1-dB compression point. This is defined as the input power (or sometimes the corresponding output power) that results in a 1-dB decrease in amplifier gain referenced to the amplifier's small-signal or linear gain.

The example in Figure 9.3 shows an amplifier's output versus input power measured at a single frequency. The amplifier has a linear region of operation at which gain is constant regardless of power level. The gain in this region is called small-signal gain and is proportional to the slope of the power response.

As the input power continues to increase, the point on the curve at which amplifier gain begins to decrease defines where the compression region begins. The amplifier's output is no longer sinusoidal in this region, and some of the output appears in harmonics rather than only in the fundamental frequency of the signal. As input power is increased, even more, the amplifier becomes saturated, and output power remains constant. At this point, the amplifier's gain drops to zero, and increases in input power will typically not produce increased output power.

To measure an amplifier's saturated output power over a power sweep, the stimulus must provide sufficient output power to drive the amplifier into saturation. A booster amplifier may be needed at the input of high-power amplifiers to achieve saturated conditions.

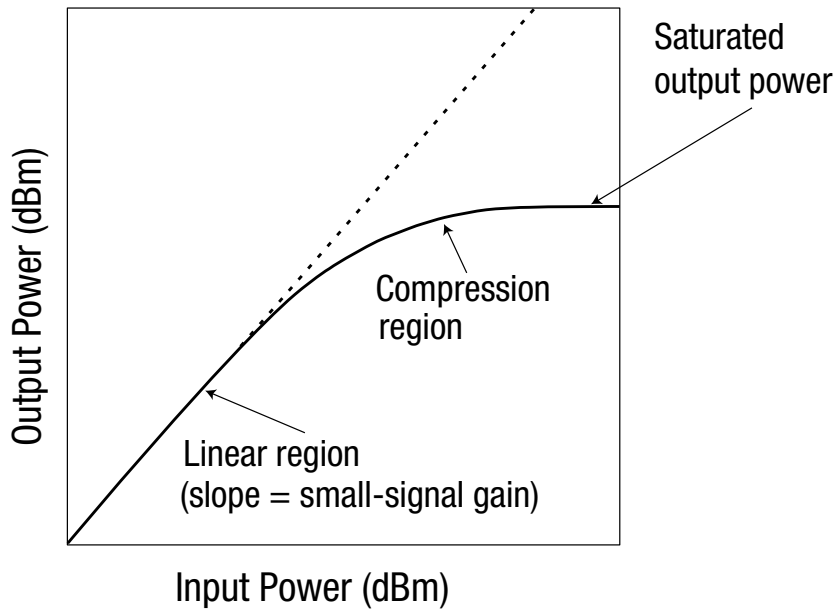
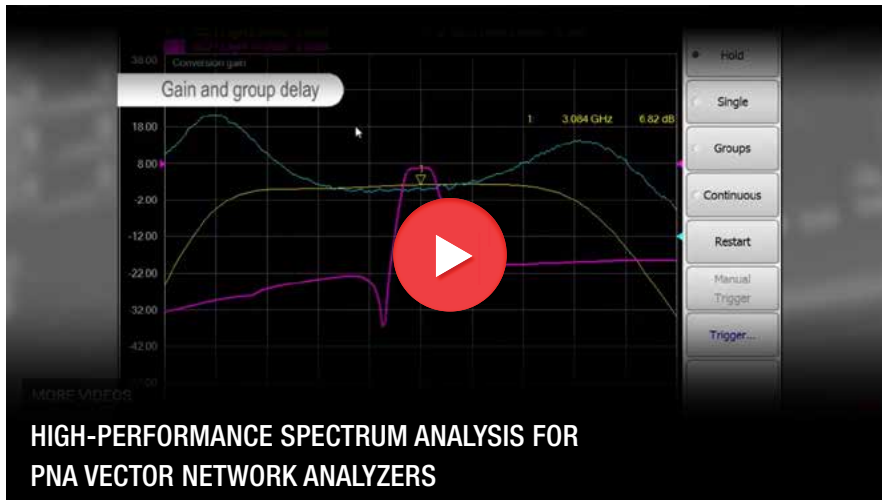

Figure 9.6. Power sweeps characterize the compression region



<https://www.keysight.com/see/radar-ew-component-test>



Chapter 10

Determine Your Optimal Noise Figure Measurement Method

Noise, and specifically signal-to-noise ratio (SNR), is a fundamental issue in wireless receivers. High noise levels will limit system performance. A sensitive receiver means you can detect lower-level signals, therefore a radar can maintain overall performance whilst transmitting at lower power, reducing size, weight, and power requirements. Noise added at an early stage can never be removed, therefore the gain and noise figure at the front-end of a receiver can dominate overall sensitivity.

Definition of Noise Figure

The noise figure F of a network is defined as the ratio of the signal-to-noise power ratio at the input to the signal-to-noise power ratio at the output.

$$F = \frac{S_i / N_i}{S_o / N_o}$$

Thus, the noise figure represents the decrease (or degradation) in the signal-to-noise ratio as the signal goes through a device or network. A perfect amplifier would amplify the noise at its input along with the signal, maintaining the same signal-to-noise ratio at its input and output (the source of input noise is often thermal noise associated with the earth's surface temperature or with losses in the system). A realistic amplifier, however, also adds some extra noise from its components and degrades the signal-to-noise ratio. A low noise figure means that very little noise is added by the network.

Noise figure can be applied to both individual components such as a single transistor amplifier, or a complete system such as a receiver. The overall noise figure of the system can be calculated if the individual noise figures and gains of the system components are known.

Noise Figure Measurement Methods

Two techniques are generally used for measuring noise figures: the Y-factor method and the cold-source method. The Y-factor method is the most common for RF and microwave frequencies (Figure 10.1). To use this technique, connect a switchable, calibrated noise source to the DUT input and connect a noise figure analyzer or signal analyzer to the output to measure the resulting noise, and then calculate the ratio. A separate calibration measurement directly measures the output of the noise source in its on ("hot") and off states, and measures the gain of the DUT.

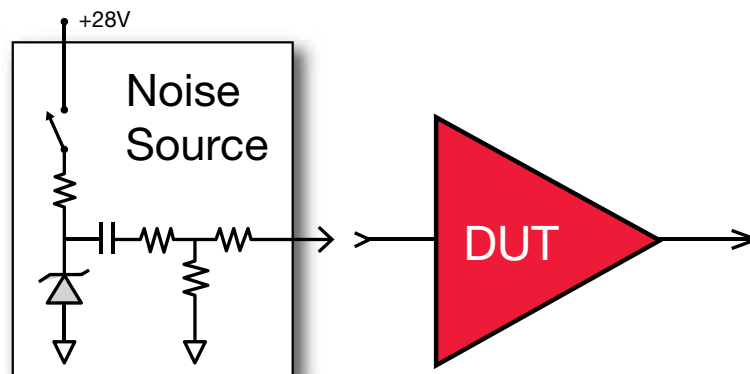

Figure 10.1. In the Y-factor method, the central element of the noise source is a diode, driven to an avalanche condition to produce a known quantity of noise power. The diode is not a dependable 50 Ω impedance, so it is often followed by an attenuator to improve impedance match with the presumed 50 Ω DUT.

The cold-source method uses a vector network analyzer (VNA) with a two-port connection to the DUT. A separate noise source is not required and a single connection to the DUT is sufficient for the entire measurement. Both methods are capable of yielding accurate measurements for receiver design and face challenges in some measurement conditions. Generally speaking, these challenges come in two forms: accurately compensating for sources of error and separating noise in the measuring receiver from noise originating in the DUT. For this chapter, we have limited our discussion to amplifiers as the DUT.

The most accurate measurements, especially those made under unfavorable conditions, are made using the cold source method. This method is especially valuable for millimeter-frequency measurements or when the input and output match of the DUT is poor—that is, substantially different from the 50 ohms assumed for instruments, cables, and accessories.

The vector calibration techniques of a VNA can account for the multiple potential mismatch errors in the measurement configuration. This reduces what is normally the largest single source of error in noise figure measurements. Impedance mismatches result in erroneous power measurements, which directly affect noise figure calculations.

Common sources of mismatch include the use of wafers, probes, or fixtures (or any type of non coaxial connection); mismatch between the DUT and noise source or analyzer; and test system signal switching. Mismatch also generally degrades as frequency increases, so the cold-source method is often the best approach for millimeter-frequency measurements.

In practice, though, most noise figure measurements are made at RF and microwave frequencies, with coaxial connections and a reasonable impedance match between the noise source, analyzer, and DUT. For these measurements, cost and convenience lead many RF engineers to choose the Y-factor method. It takes advantage of the signal analyzer that is more likely to be on their bench. These are usually less expensive than VNAs and can provide a good combination of accuracy and measurement cost.

With these tradeoffs in mind, it important to pay some attention to the unfavorable conditions that can make measurements difficult or substantially increase error:

- DUTs with a combination of low gain and very good noise figure: Such devices will generate very little incremental noise. This may result in a signal at the analyzer input that is difficult to measure accurately because it is very close to the analyzer's noise floor.
- Conducted or radiated interference: Analyzers have no way of separating power that is due to either conducted or radiated interference. If possible, measurements should be made in shielded enclosures, with mobile phones and networks excluded, and on battery power, if practical.
- Complex or lengthy connections or adapters: Cabling and adapters can spoil impedance match and attenuate the noise power that is supplied or measured. Custom cabling, which eliminates the need for adapters or extra length, can be an inexpensive way to improve measurement performance and reduce error.
- Inconsistent connections between calibration and measurement steps: Cable and connector care and connection techniques, including proper torque, are especially important.

- Devices that change temperature and drift during measurements: Noise figure measurements and uncertainty calculations assume static parameters. Any drift (or other changes) after calibration or during the measurement process will have a direct effect on accuracy.
- Finally, external or internal preamplifiers can improve noise figure accuracy by improving the noise floor of the measuring instruments. To be beneficial, these preamplifiers should have extremely low noise figures over the frequencies of interest.

Summary of Measurement Solutions

Keysight offers three types of solution platforms: a dedicated noise figure analyzer, signal/spectrum analyzers, and vector network analyzers. The benefits of each are outlined below.

Noise figure analyzer (NFA)

The NFA Series is made exclusively for accurate noise figure measurements and uses the Y-factor method. The analyzer includes the following standard options; precision frequency reference, internal preamplifier, fine step attenuator, noise floor extension, 25 MHz analysis bandwidth, U7227A, C, or F USB external preamplifier, and a convenient snap-on pouch to hold accessory items. Four model numbers covering frequency ranges 3.6, 7, 26.5, and 40 GHz can be extended to 110 GHz with a block downconverter. The series offers a low instrument noise figure, full-featured signal analyzer, and IQ Analyzer (Basic) modes that extend beyond a dedicated noise figure analyzer.

Signal/spectrum analyzers

Adding an optional noise figure measurement application to a versatile signal or spectrum analyzer is an economical way to add noise figure capabilities. The accuracy and frequency range of this solution depends on which base instrument it is installed. Signal/spectrum analyzers use the Y-factor method to measure noise figure. Preamplification, either external or internal, often improves accuracy.

Network analyzers

If you need noise figure measurements with the highest accuracy, choose Keysight's PNA-X network analyzer with the noise figure option. This solution is based on the cold-source technique, and it allows S-parameter and noise figure measurements with a single connection to the DUT.

When selecting an instrument to meet your needs, it is first important to select one that will cover the frequency range of your DUT.



<https://www.keysight.com/see/radar-ew-component-test>



Chapter 11 Select the Appropriate Phase Noise Test Solution

Phase noise is the random short-term phase fluctuation of a carrier signal which can limit the performance of a Doppler radar system. Doppler radars determine the velocity of a target by measuring the small shifts in frequency that return echoes have undergone. In actual systems, however, the return signal is much more than just the target echo. The return includes a ‘clutter’ signal from the large, stationary earth as shown in Figure 11.1. If this clutter return is decorrelated by the delay time difference, the phase noise from the local oscillator can spread the spectral density of the earth return signals to mask the target signal, partially or completely. Thus, phase noise on the local oscillator or in any component in the transmit or receive signal chains can set the minimum signal level that must be returned by a target to detectable.

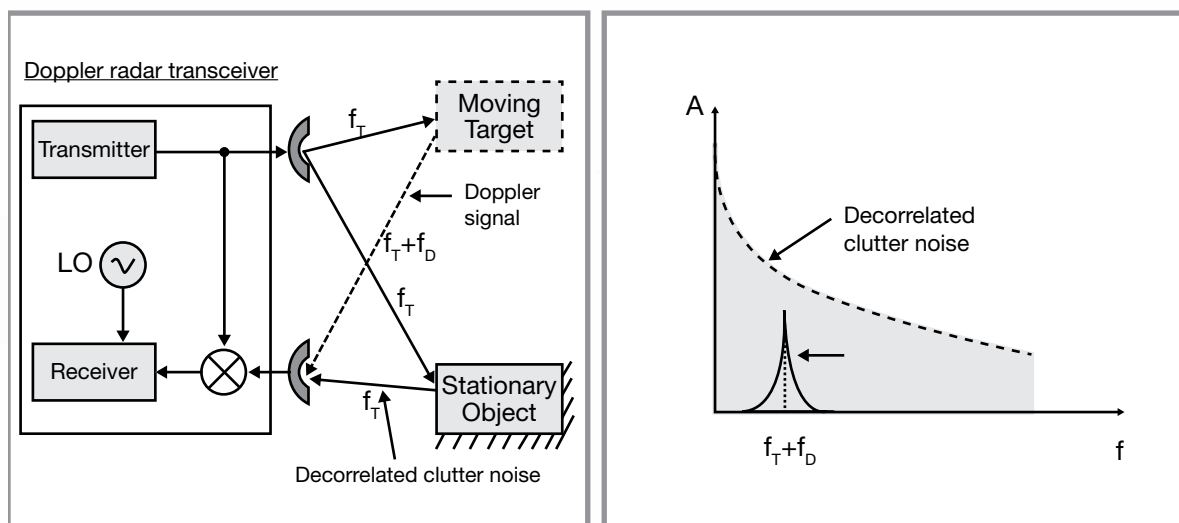
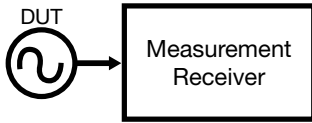

Figure 11.1. Effect of carrier phase noise in a Doppler radar system.

Phase Noise Measurement Modes

There are four primary phase noise measurement modes, tailored to the needs of measuring the phase noise contribution of four corresponding types of Devices Under Test (DUTs) with the following phase noise measurement topologies:

Absolute 1-Port



Absolute phase noise measurements for DUTs with one output port, such as oscillators or signal generators with internal references, require only a phase noise measurement receiver to measure the output of the DUT since the stimulus source is internal.

Residual 2-Port Non-Frequency Translating

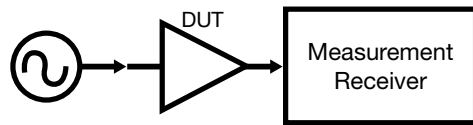

Residual phase noise measurements of two-port non-frequency translating devices, such as amplifiers, require both a phase noise measurement receiver and a stimulus source, the latter to drive the input of the DUT. Both the receiver and the stimulus source operate at the same frequency.

Residual 2-Port Frequency Translating

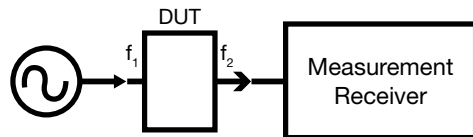

Residual phase noise measurements of two-port frequency translating devices, such as multipliers and dividers, require both a phase noise measurement receiver and a stimulus source that operate at different frequencies.

Residual 3-Port Frequency Translating

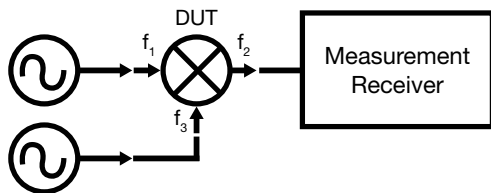

Residual phase noise measurements of three-port frequency translating devices, such as mixers, also require both a phase noise measurement receiver and a stimulus source that operate at different frequencies, but also a second stimulus source for the Local Oscillator (LO) that operates at a third frequency.

Figure 11.2. Phase noise measurement topologies

Note that all three residual two-port measurement modes also apply to devices with multiple outputs, if the outputs can be measured one at a time.

Phase Noise Measurement Methods

There are two primary methods of measuring phase noise:

- a.) Direct spectrum method,
- b.) Carrier removal method.

Direct spectrum method

By sampling the carrier of the DUT, the direct spectrum method as employed by Keysight's vector signal and network analyzers immediately provides amplitude and phase information by performing a complex FFT of the digitized time record. Unlike legacy noise measurement applications found in scalar analyzers that measured the power spectral density of a swept signal trace and presented both the amplitude and phase modulation contributions of noise, modern vector analyzers can suppress the amplitude modulation noise component and present only the phase noise component as shown in Figure 11.3.

The direct spectrum method is the most convenient and lowest cost solution since it is included with signal and network analyzers and does not require extra equipment. But due to the presence of the DUT's carrier signal, the measurement sensitivity is limited by the phase noise of the analyzer, typically set by the dynamic range of the digitizer.

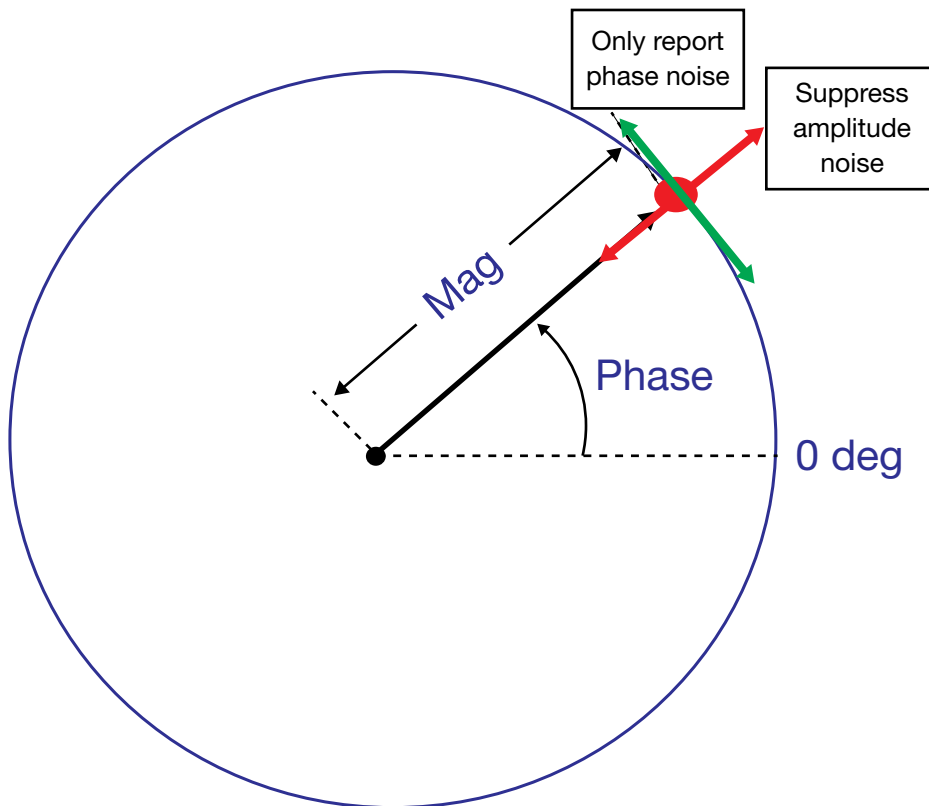

Figure 11.3. Phase noise direct spectrum method by employing vector analyzer removal of amplitude noise.

Carrier removal method

For the most demanding low phase noise measurements, increased sensitivity is obtained by nulling the carrier, using a double-balanced mixer, and combining the DUT signal with a reference signal of the same frequency that is 90 degrees out of phase, in 'quadrature'. Without the carrier, the phase noise measurement receiver's Low Noise Amplifier (LNA) gain can be increased to amplify the noise signal far enough to overcome the noise floor limitation of the digitizer without clipping. The theoretical sensitivity limitation for phase noise measurements then becomes the difference between the power of the DUT and thermal phase noise floor of -177 dBm at 290 degrees K, minus the noise contribution of the stimulus and reference sources and LNAs. The Carrier Removal Method is employed by Keysight's Signal Source Analyzers (SSAs) and Phase Noise Measurement Systems (PNTSs).

Absolute Phase Noise Measurements using the Carrier Removal Method

There are two ways to make absolute measurements using the carrier removal method, Frequency Modulation (FM) discrimination where the quadrature signal is driven by the DUT through a 90-degree delay line, and a Phase-Locked Loop (PLL) reference source locked 90 degrees out of phase to the DUT. The frequency discriminator method is the most cost-effective, using the least equipment and being well suited for measuring free-running oscillators with large excursions from a nominal frequency. But FM Discrimination has sensitivity limitations, radar oscillators are amongst the lowest noise, and typically are not drifting in a free-running mode, so FM discrimination will not be discussed here. We will focus instead on the PLL reference source method that is employed by Keysight's SSAs and PNTSs.

To achieve quadrature for the absolute PLL reference source phase noise measurement, a reference source is locked to the DUT by a PLL that drives the output voltage of the double-balanced mixer to 0V. The absolute PLL phase noise measurement block diagram utilizing the carrier removal method is shown in Figure 11.4.

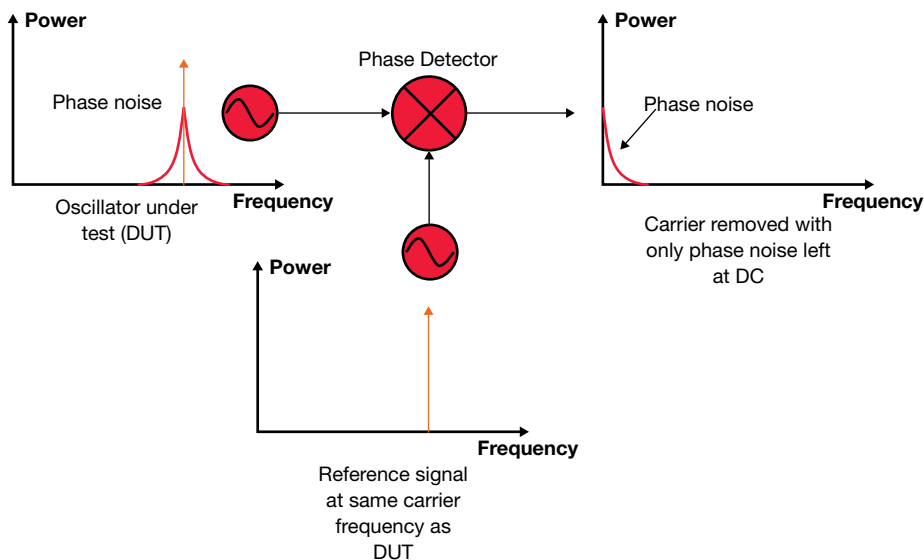

Figure 11.4. PLL reference source is used to remove the carrier for an absolute phase noise measurement utilizing the carrier removal method.

Residual Phase Noise Measurements Using the Carrier Removal Method

To achieve quadrature for the residual measurement case, a stimulus source output power is split into two paths. One path goes straight to the LO input of the double-balanced mixer, and the other path goes through the DUT, then a delay line, then a phase shifter to achieve a total of 90 degree phase shift before being injected in to the RF input of the mixer to obtain quadrature and remove the carrier. The two-port non-frequency translating phase noise measurement block diagram utilizing the carrier removal method is shown in Figure 11.5.

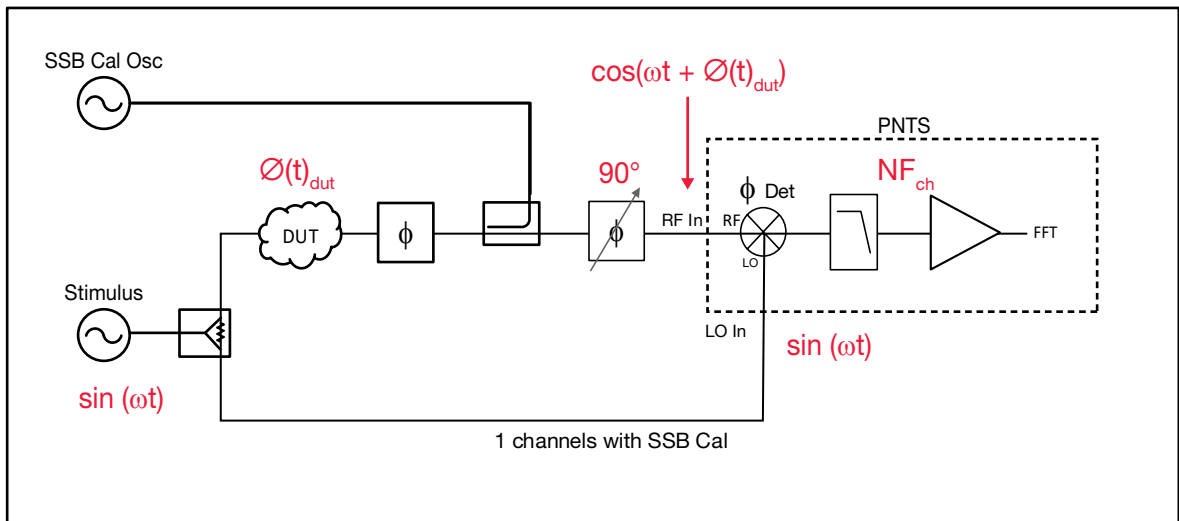

Figure 11.5. Residual phase noise measurement.

Two Channel Cross-Correlation

To eliminate the noise contribution of the reference source, LNA, and receiver, two-channel cross-correlation is employed by Keysight's SSA and PNTS. The FFT of one channel is multiplied by the complex conjugate of the other channel and then averaged over subsequent FFTs which maintains the coherent DUT noise found on both channels but diminishes the non-coherent noise generated independently by the equipment in each channel of the measurement system. 5 dB sensitivity improvement is gained by every order of magnitude more cross-correlations. This adds some complexity and can significantly add to measurement time if the reference sources have significantly higher phase noise than the DUT, but it allows measurements made down to the thermal noise floor given enough time.

Table 11.1 shows system sensitivity vs. DUT input power.

P_{carrier} dBm	Phase Noise $\mathcal{L}(f_m)$, dBc/Hz
+20	-197
+10	-187
0	-177
-10	-167
-20	-157

Table 11.1. Theoretical two-channel cross-correlated sensitivity limits vs. DUT output power.

For faster measurement time of improved sensitivity measurements, Keysight's PNTS provides the additional flexibility to use high performance external references and stimulus sources, including duplicates of one-port DUTs. Table 11.2 shows the improvement of sensitivity with number of cross-correlations.

Number of cross-correlations, M	10	100	1,000	10,000
Noise reduction on $N_1 + N_2$	-5 dB	-10 dB	-15 dB	-20 dB

Table 11.2. Phase noise measurement sensitivity improvement above the thermal noise floor vs. number of cross-correlations.

Keysight Phase Noise Measurement Solutions

Different solutions are available for measuring phase noise. The appropriate solution will depend on cost and performance constraints. Although phase noise measurements on CW signals within the radar, including the Stable Local Oscillator (STALO) and Coherent Oscillator (COHO), are critical, it may also be necessary to measure the phase noise of pulsed signals or understand the phase noise contributed by system components such as the power amplifier (residual or additive phase noise). This is especially true for Doppler radars in which it is critical to understand the phase noise through the transmit path under normal operating conditions.

A signal analyzer-based phase noise measurement solution typically offers the lowest cost option for absolute measurement. Oscilloscopes can measure very wide (multi-GHz) offset on high-frequency carriers. Modern VNAs incorporating high-quality signal sources can make absolute and residual measurements at offsets to 10 MHz. A dedicated signal source analyzer such as the Keysight Signal Source Analyzer (SSA) provides high performance and efficiency for measuring oscillators and phase locked loops (PLLs) at offsets to 30 MHz. A Phase Noise Test System is more complex but offers the greatest flexibility and performance including measurement of pulsed signals.

The choice of measurement solution will depend on DUT characteristics such as operating frequency, measurement offset, and the target specification to be measured. Table 11.3 provides a comparison of four phase noise measurement solution families used for radar and EW, followed by a brief overview for each.

Attribute	Infiniium UXR, MXR Oscilloscopes	N9068A Phase Noise X-Series Signal Analyzers Measurement Application	S930317B PNA and PNA-X Network Analyzers Phase Noise Measurement Application	E5052B Signal Source Analyzer	N5511A Phase Noise Test System using 2 E8257D Option UNY PSGs
Absolute Measurements	Yes	Yes	Yes	Yes	Yes
Residual Measurements	No	Yes, but with external stimulus source and subtraction	Yes	No	Yes
Frequency Range	DC to 110 GHz	3 Hz to 110 GHz; >>110 GHz with external mixer	10 MHz to 125 GHz	10 MHz to 26.5 GHz; >>110 GHz with external mixer	50 kHz to 40 GHz; >> 110 GHz with external mixer
Frequency Offsets	1 KHz to 55 GHz	1 Hz to 10 MHz	0.1 Hz to 10 MHz	1 Hz to 100 MHz	0.01 Hz to 160 MHz
Noise Floor at 10 GHz carrier and 10 kHz offset	-121 dBc/Hz	-134 dBc/Hz	-140 dBc/Hz	-137 dBc/Hz (after 1 cross correlation at 1 Hz offset)	-170 dBc/Hz (after 1 cross correlation at 1 Hz offset)
Cross Correlation	Yes	No	No	Yes	Yes
VCO Measurements	Yes (requires external DC source)	No	No	Yes	Yes (FM Discriminator Method)
Baseband Noise Measurements	Yes	No	No	Yes	Yes
AM Noise Measurement	Combined	Combined	Combined	Combined	Separate Input
Other Measurements	Oscilloscope	Signal Analyzer	Network Analyzer	Signal Analyzer (subset)	None
Measurement System Complexity	Moderate (external splitters)	Low (all internal)	Low (all internal)	Low (all internal)	High (external splitters and signal sources)
Method	Direct Spectrum	Direct Spectrum	Direct Spectrum	Carrier Removal	Carrier Removal

Table 11.3. Keysight phase noise measurement solution portfolio comparison.

Infiniium real-time oscilloscopes

Keysight's Infiniium real-time oscilloscopes now provide FFT phase noise measurements. To overcome lower sensitivity that comes as a tradeoff for wider bandwidth digitization, two channels can now be used to cross-correlate and reduce the noise contribution of the measurement receiver. This requires adding a power splitter or double-probing each signal being measured to route it to two channels. Differential signals can be measured directly with 4-channel oscilloscopes (there is no need for an external balun to transform from balanced to unbalanced signal). Figure 11.6 shows the oscilloscope phase noise interface.



Figure 11.6. Infiniium Real-Time Oscilloscope phase noise interface.

X-series signal analyzer phase noise measurement application

Many spectrum analyzers include automated single-sideband (SSB) phase noise measurement functions for CW signals. The range of offsets and levels of the phase noise that can be measured by a signal analyzer will depend on the available RBW settings and the phase noise of the instrument itself.

The Keysight N9068A phase noise X-series signal analyzers measurement application can make absolute phase noise measurements of one port devices and is available on all X-Series spectrum analyzers. With the addition of a low phase noise stimulus source such as the Keysight E8257D Option UNY Precision Signal Generator (PSG), it can also be used to make residual measurements on two-port devices by first measuring the PSG, measuring the device under test (DUT), and subtracting the results. The N9068A application interface is shown in Figure 11.7.



Figure 11.7. Keysight X-Series signal analyzers phase noise measurement application.

Network analyzer phase noise measurement application

With significant advancements made in the quality of signal sources embedded within network analyzers, it becomes possible to make a phase noise measurement using a VNA. This has the convenience of capturing multiple parametric measurements at a single test station with the DUT connected one time.

Keysight PNA Microwave Network Analyzers are fitted with enhanced low phase noise Direct Digital Synthesis (DDS) stimulus sources. A dedicated phase noise measurement application supports absolute phase noise measurements and residual noise measurements, without the need for external excitation sources. The phase noise measurement sensitivity is -97 dBc/Hz^1 at 100 Hz offset from a 10 GHz carrier.

The offset frequency range is 0.1 Hz to 10 MHz, and the sweep speed (typical) is 34 seconds (1 Hz to 10 MHz offset in normal mode). This application can also make AM noise, spurious and integrated noise measurements.

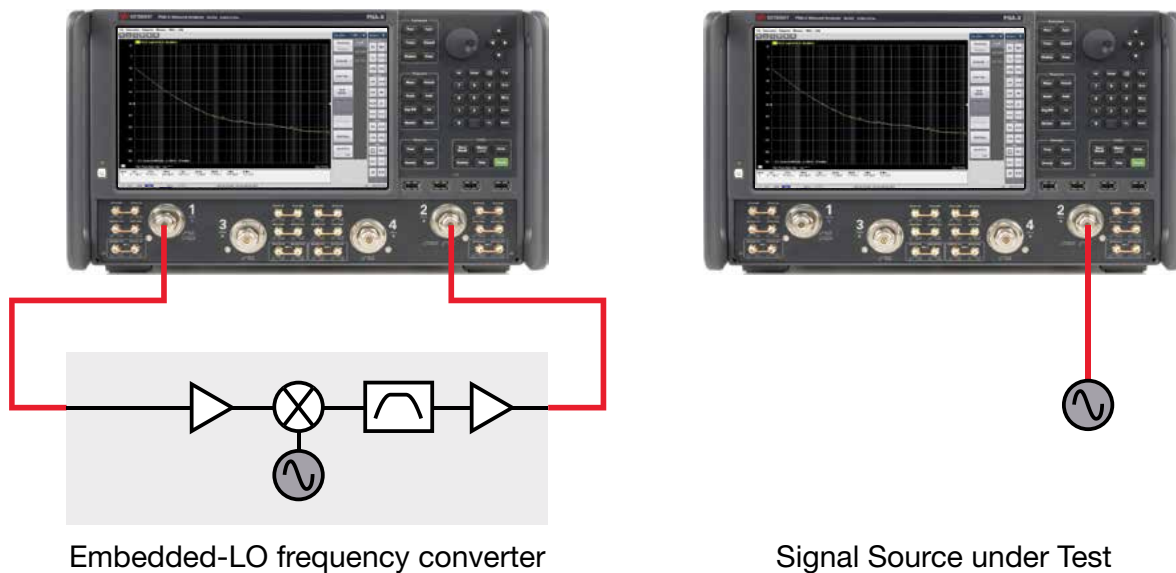

Figure 11.8. Residual and Absolute Phase Noise Measurement on a PNA.

The PNA is architected with multiple internal DDS sources (RF and LO sources) and multiple receivers. The internal sources are all correlated. When you make 2-port or 3-port device measurements, the sources cancel the phase noise and provide better measurement sensitivity, especially at close-in offset frequencies. The sensitivity of frequency converter embedded-LO phase noise measurement is determined by the phase noise of the DDS source at the carrier frequency of the embedded LO. When the PNA provides both IF and LO or RF and LO a mixer under test, the phase noise cancellation is even larger and makes the sensitivity drastically high, -86 dBc/Hz^1 at 1 Hz offset from a 10 GHz carrier.

The N522xB PNA and N524xB PNA-X with S930317B/S930321B phase noise measurement application simplifies your active device measurement configuration by using the same cable connection as other measurements such as S-parameters, noise figure, gain compression, IMD, group delay, and reduces the total test time significantly. Higher frequency models of the PNA like 67 GHz N5247B PNA-X and 125 GHz N5291A allow you to perform the phase noise measurement at millimeter-wave frequencies without using harmonic mixers.

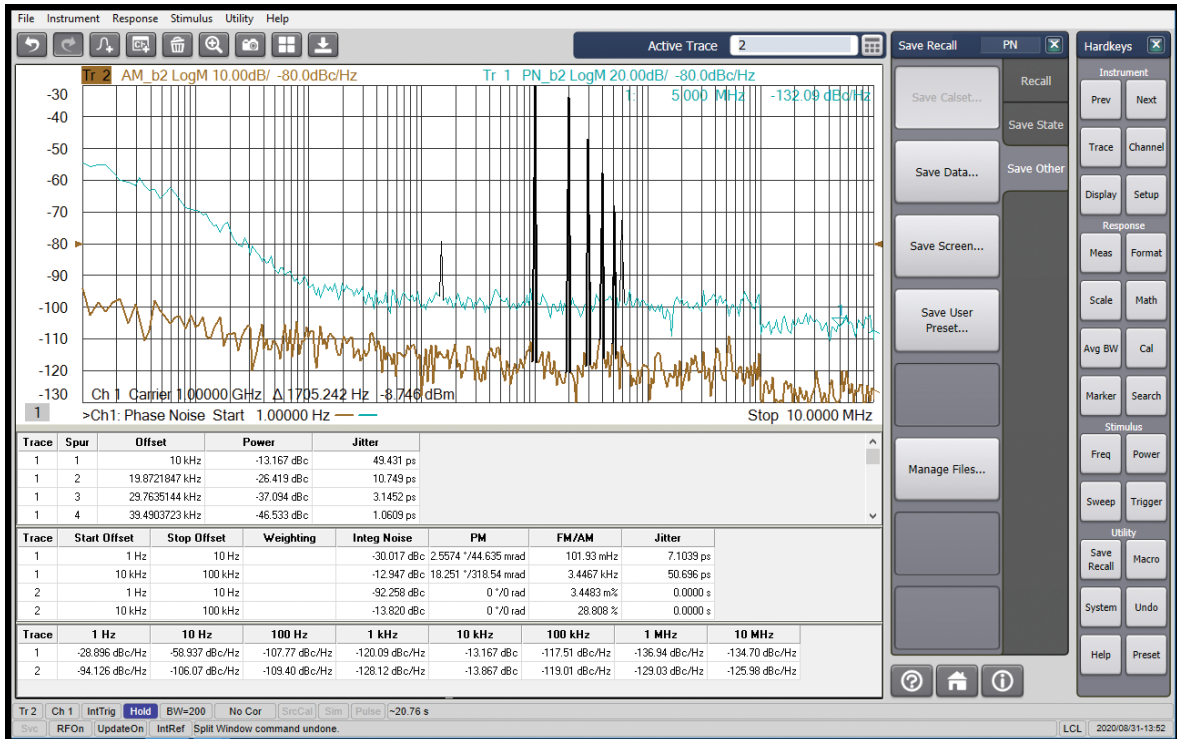

Figure 11.9. Keysight PNA phase noise application includes capability to measure AM noise and spurious.

Signal source analyzer

The Keysight E5052B signal source analyzer is one such instrument that employs cross-correlation techniques to dramatically improve measurement performance. For convenience, the analyzer includes its own reference oscillators. The SSA is designed to efficiently and rapidly process cross-correlations to obtain maximum performance and efficiency. As a result, the SSA offers a very high level of performance while keeping costs low.



Figure 11.10. Keysight signal source analyzer.

In addition to phase noise, the DSP-based SSA also provides many other functions that can be useful for the testing of radar oscillators. Because it samples the signal and is DSP-based, the analyzer includes the ability to analyze amplitude, frequency, and phase as a function of time. It can also perform transient analysis by triggering frequency anomalies. The SSA provides two receiver channels: a wideband channel to monitor frequency change and a narrowband channel to capture the frequency-versus-time profile precisely. The signal can be measured simultaneously on both channels while either the wideband or narrowband channel monitors the signal for frequency changes. These frequency changes can then trigger and capture the transient event.

Phase noise test system

Dedicated test systems represent the “gold standard” for phase noise measurement. The Keysight N5511A Phase Noise Test System (PNTS) can measure phase noise down to kT (-177 dBm/Hz at room temperature). This thermal phase noise floor is the theoretical limit for any measurement. Therefore, the PNTS can measure at the limits of physics. A modular instrument architecture takes advantage of standalone instrumentation for a superior frequency offset range of 160MHz, broadest capability, best sensitivity, and excellent speed of phase noise measurement.



Figure 11.11. Keysight phase noise test system with two PSGs.

The first architectural feature of the PNTS that minimizes the cross-correlation time penalty is the field programmable gate array (FPGA) processing of all FFTs and cross-correlations in real-time. This means that cross-spectral averaging is performed in FPGA hardware rather than in software on a microprocessor and is therefore much faster. The computations are performed on all offset frequency segments of the trace in parallel (multi-segment parallel processing) and displayed in real-time.

The second architectural feature that PNTS has that minimizes the cross-correlation time penalty is the ability to use any electronic frequency tunable reference. This allows the use of the best available signal generators today (or even use copies of the DUT as references) and gets better performance in the future as newer and higher-performance signal generators come to market. This reduces the cross-correlation time penalty because lower phase noise (better performance) references add less uncorrelated noise to the measurement and thus require fewer correlations (and less time) to suppress this lower uncorrelated reference noise and allow the user to observe their device's true phase noise.

Pulsed and residual phase noise measurements are especially helpful for pulsed radar systems. The N5511A can perform residual measurements on pulsed RF carriers as well as absolute measurements on pulsed carriers. The phase detector modules in the N5511A come equipped with multiple internal PRF (pulse repetition frequency) filters; these are low pass filters (LPFs) because all analog and digital signal processing performed after the phase detectors in PNTS is performed at baseband. However, if there is a measurement requirement for LPFs with different cutoff frequencies than the ones provided, N5511A offers the flexibility of adding user-supplied external filters.



<https://www.keysight.com/see/radar-ew-component-test>

Chapter 12

Measure S-Parameters With Increased Confidence

Network analyzers characterize radio frequency (RF) devices. Although they began measuring S-parameters, network analyzers have become highly integrated and advanced to stay ahead of the devices they test. Today, most network analyzers are vector network analyzers — measuring both magnitude and phase. Vector network analyzers are extremely versatile instruments that can characterize scattering-parameters (S-Parameters), match complex impedances, make pulsed measurements, measure distortion, noise figure, phase noise, and more.

Keysight offers the broadest range of network analyzer models and form factors — from the portable FieldFox to the highly integrated PNA which can be configured with three high-performance, low phase-noise signal generators.



Figure 12.1. Keysight network analyzer portfolio

S-Parameter Basics

S-Parameter design and measurement fundamentals is a topic beyond the scope of this chapter.

The number of S-parameters for a given device is equal to the square of the number of ports. For example, a two-port device has four S-parameters. The numbering convention for S-parameters is that the first number following the S is the port at which energy emerges, and the second number is the port at which energy enters. So, S₂₁ is a measure of power emerging from Port 2 as a result of applying an RF stimulus to Port 1. When the numbers are the same (e.g. S₁₁), a reflection measurement is indicated.

The Power of S-parameters

- Relate to familiar measurements (gain, loss, reflection coefficient, etc.)
- Relatively easy to measure
- Can cascade S-parameters of multiple devices to predict system performance
- Analytically convenient
 - CAD programs
 - Flow-graph analysis

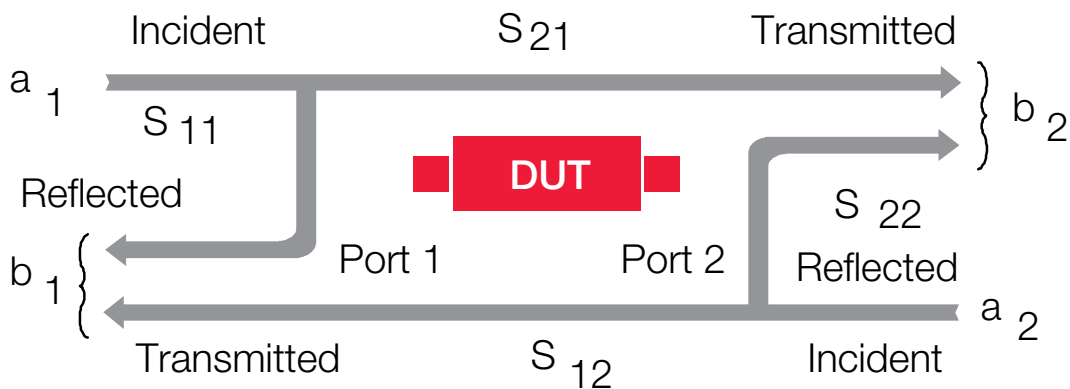

$$b_1 = S_{11} a_1 + S_{12} a_2$$
$$b_2 = S_{21} a_1 + S_{22} a_2$$

Figure 12.2. S-parameters

Forward S-parameters are determined by measuring the magnitude and phase of the incident, reflected, and transmitted signals when the output is terminated in a load that is precisely equal to the characteristic impedance of the test system. In the case of a simple two-port network, S₁₁ is equivalent to the input complex reflection coefficient or impedance of the DUT, while S₂₁ is the forward complex transmission coefficient. By placing the source at the output port of the DUT and terminating the input port in a perfect load, it is possible to measure the other two (reverse) S-parameters. Parameter S₂₂ is equivalent to the output complex reflection coefficient or output impedance of the DUT while S₁₂ is the reverse complex transmission coefficient (Figure 12.3).

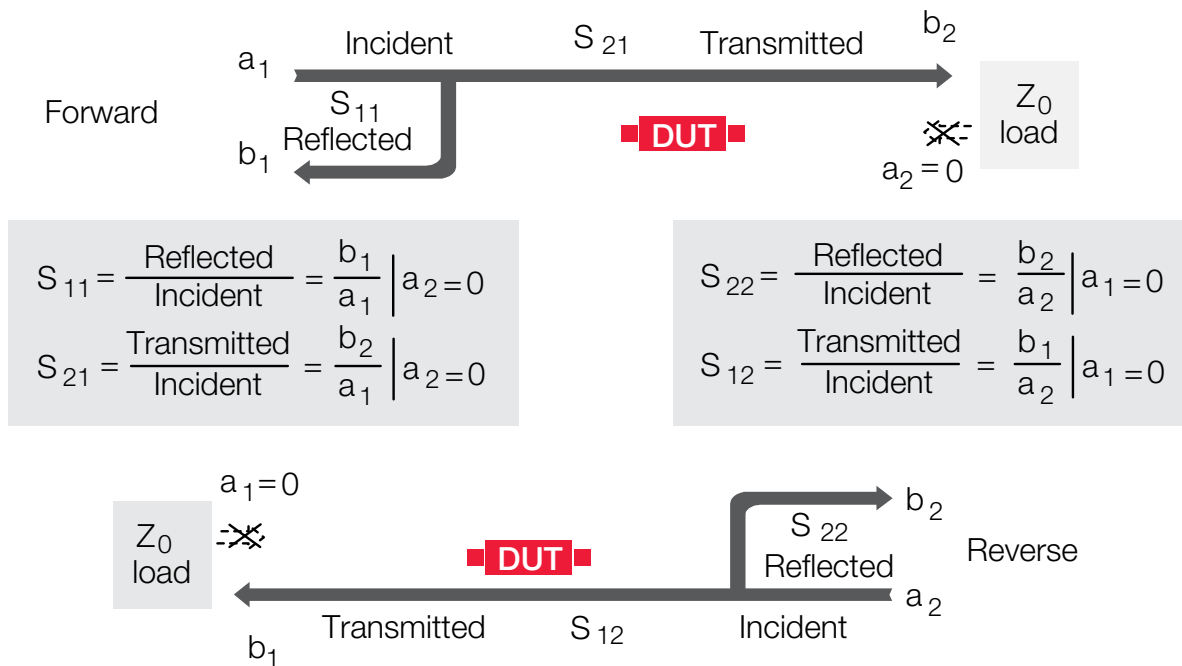

Figure 12.3. Measuring S-parameters

How to Boost and Attenuate Signal Levels When Measuring High-Power Amplifiers

Testing high-power amplifiers can sometimes be challenging since the signal levels needed for the test may be beyond the stimulus/response range of the network analyzer. High-power amplifiers often require high input levels to characterize them under conditions similar to actual operation. Often these realistic operating conditions also mean the output power of the amplifier exceeds the compression or burn-out level of the analyzer's receiver.

When you need an input level higher than the network analyzer's source can provide, a preamplifier can be used to boost the power level before the amplifier under test (AUT). By using a coupler on the output of the preamplifier, a portion of the boosted input signal can be used for the analyzer's reference channel (Figure 12.4). This configuration removes the preamplifier's frequency response and drift errors (by rationing), which yields an accurate measurement of the AUT alone.

When the output power of the AUT exceeds the input compression level of the analyzer's receiver, some type of attenuation is needed to reduce the output level. This can be accomplished by using couplers, attenuators, or a combination of both. Care must be taken to choose components that can absorb the high power from the AUT without sustaining damage. Most loads designed for small-signal use can only handle up to about one watt of power. Beyond that, special loads that can dissipate more power must be used.

The frequency-response effects of the attenuators and couplers can be removed or minimized by using the appropriate type of error-correction. One concern when calibrating with extra attenuation is that the input levels to the receiver may be low during the calibration cycle. The power levels must be significantly above the noise floor of the receiver for accurate measurements. For this reason, network analyzers that have narrowband tuned receivers are typically used for high-power applications since their noise floor is typically 90 dBm, and they exhibit excellent receiver linearity over a wide range of power levels.

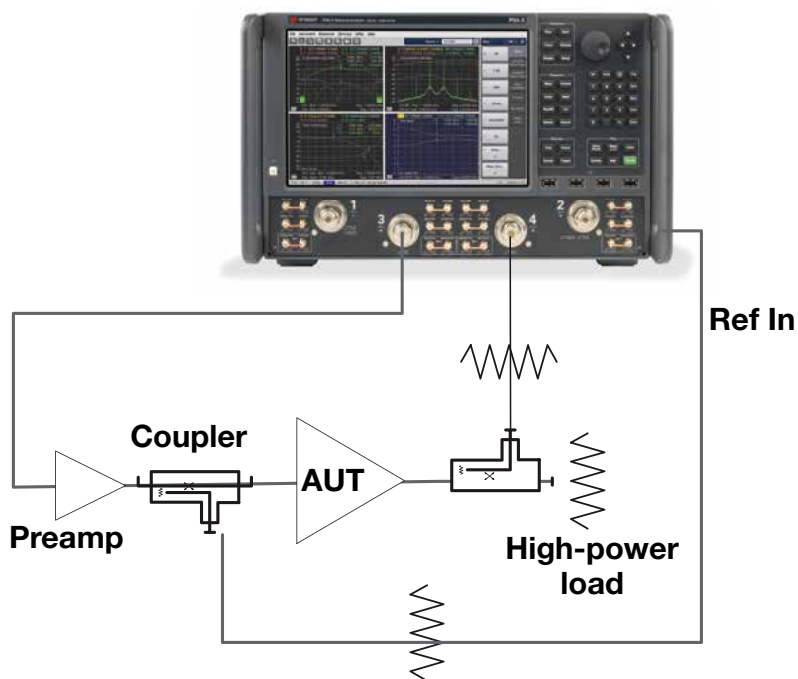

Figure 12.4. High-powered forward measurement configuration

Some network analyzers with full two-port S-parameter capability enable measuring of the reverse characteristics of the AUT to allow full two-port error correction. In this configuration, the preamplifier must be added to the signal path before the port 1 coupler (Figure 12.5). Otherwise, the preamplifier's reverse isolation will prevent accurate measurements from being made on port 1. If attenuation is added to the output port of the analyzer, it is best to use a higher power in the reverse direction to reduce noise effects in the measurement of S22 and S12. Many VNAs allow uncoupling of the test port power to accommodate different levels in the forward and reverse directions.

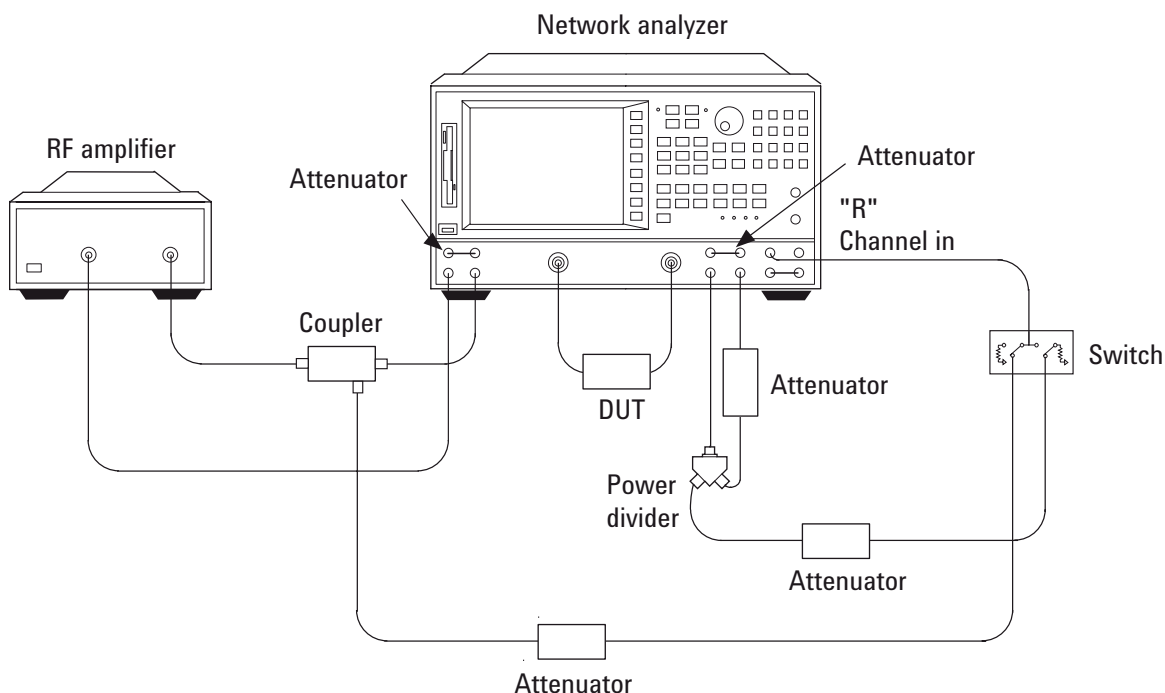

Figure 12.5. High-powered forward and reverse measurement configuration

Pulsed RF Component Testing

Many RF and microwave amplifiers used in commercial and aerospace/defense applications require testing using a pulsed-RF stimulus. This section focuses on new pulsed-RF S-parameter measurement techniques that can be accomplished with microwave vector network analyzers.

The topic of pulsed-RF testing is often focused on measuring the pulses themselves. This is critical, for example, in evaluating radar system performance and effectiveness. When measuring components, however, the pulses are merely the stimulus, and the VNA measures the effect that the device under test (DUT) has on the pulsed stimulus. Any non-ideal behavior of the pulses themselves is removed from the measurement since the VNA performs ratioed measurements. This means that each S-parameter measurement compares a measured reflection or transmission response with the incident signal, providing ratioed magnitude and phase results. Figure 12.6, shows the configuration for measuring

forward S-parameters: the R receiver measures the incident signal, the A receiver measures the reflection response, and the B receiver measures the transmission response. S11 is the complex ratio of the A and R receivers, and S21 is the complex ratio of the B and R receivers.

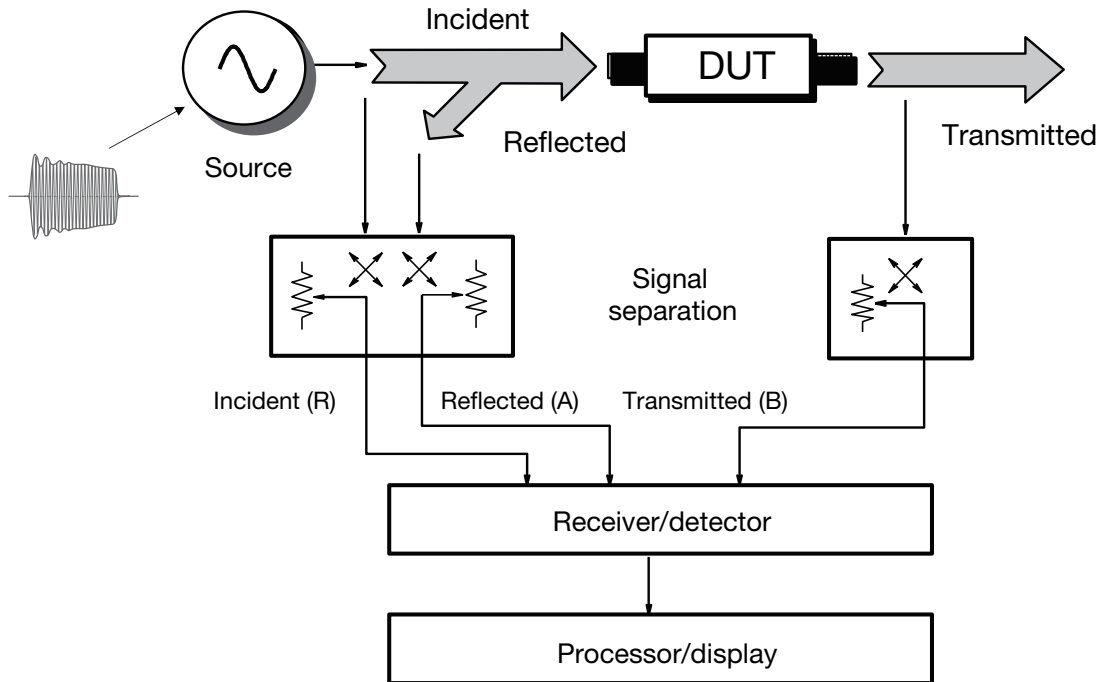

Figure 12.6. Simplified vector network analyzer block diagram

There are three major types of pulsed-RF measurements as shown in Figure 12.7. The first two are pulsed S-parameter measurements, where a single data point is acquired for each carrier frequency. The data is displayed in the frequency domain with magnitude and/or phase of transmission and/or reflection. Average pulse measurements do not attempt to position the data point at a specific position within the pulse. For each carrier frequency, the displayed S-parameter represents the average value of the pulse. Point-in-pulse measurements result from acquiring data only during a specified gate width and position (delay) within the pulse. There are different ways to do this in hardware, depending on the type of detection used, which will be covered later. Pulse profile measurements display the magnitude and/or phase of the pulse versus time, instead of frequency. The data is acquired at uniformly spaced time positions across the pulse while the carrier frequency is fixed at some desired frequency.

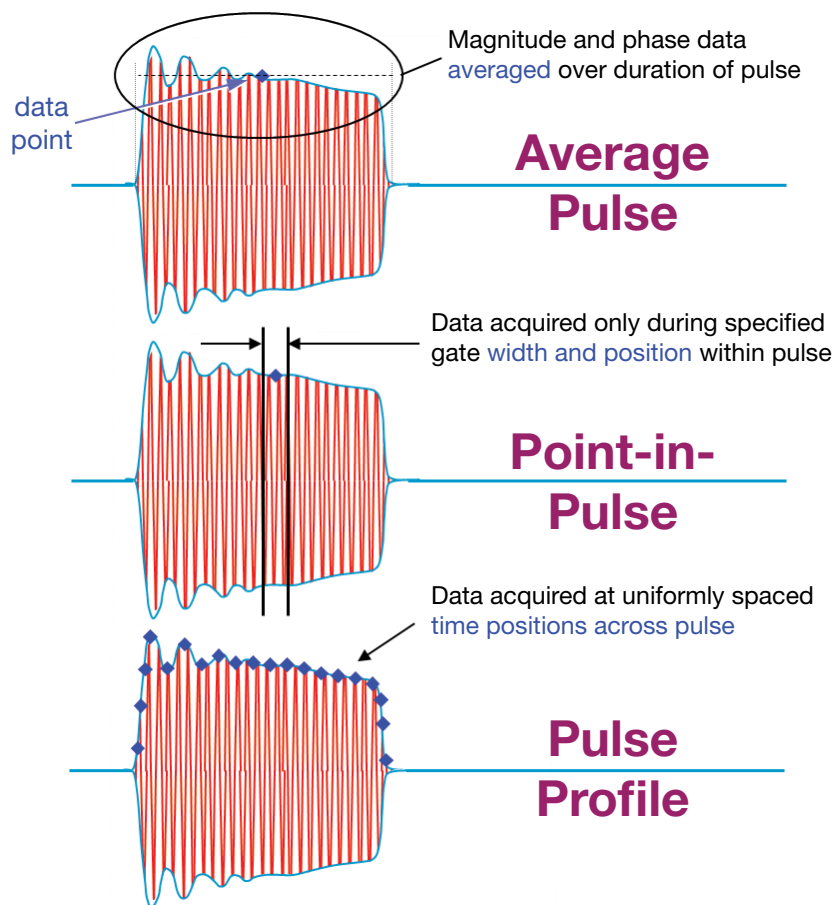

Figure 12.7. Average, point-in-pulse, and pulse profile measurements

Pulsed-RF detection techniques Figure 12.8 shows an important measure of a pulsed RF signal and its relationship between the time and frequency domain. When a signal is switched on and off in the time domain (pulsed), the signal's spectrum in the frequency domain has a $\text{sinc}(x)/x$ response. The width of the lobes is inversely related to the pulse width (PW). This means that as the pulses get shorter in duration, the spectral energy is spread across a wider bandwidth. The spacing between the various spectral components is equal to the pulse repetition frequency (PRF). If the PRF is 10 kHz, then the spacing of the spectral components is 10 kHz. In the time domain, the repetition of pulses is expressed as pulse repetition interval (PRI) or pulse repetition period (PRP), which are two terms with the same meaning.

Another important measure of a pulsed RF signal is its duty cycle. This is the amount of time the pulse is on, compared to the period of the pulses. A duty cycle of 1 (100%) would be a CW signal. A duty cycle of 0.1 (10%) means that the pulse is on for one-tenth of the overall pulse period. For a fixed pulse width, increasing the PRF will increase the duty cycle. For a fixed PRF, increasing the pulse width increases the duty cycle. The duty cycle will become an important pulse parameter when we look at narrowband detection.

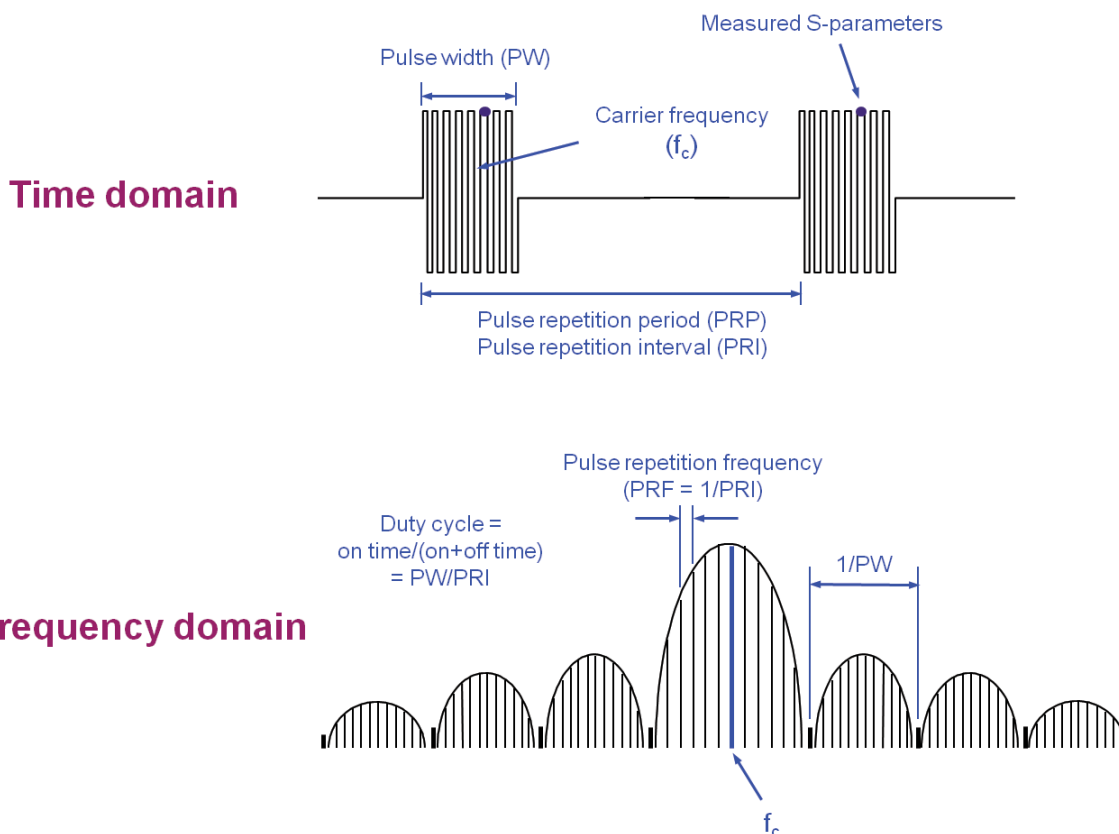

Figure 12.8. Pulsed-RF network analysis terminologies

Wideband detection can be used when the majority of the pulsed-RF spectrum is within the bandwidth of the receiver. In this case, the pulsed-RF signal will be demodulated in the instrument, producing baseband pulses. With wideband detection, the analyzer is synchronized with the pulse stream, and data acquisition only occurs when the pulse is in the “on” state. This means that a pulse trigger that is synchronized to the PRF must be present; for this reason, this technique is also called synchronous acquisition mode. The advantage of the wideband mode is that there is no loss in dynamic range when the pulses have a low duty cycle (long time between pulses). The measurement might take longer, but since the analyzer is always sampling when the pulse is on, the signal-to-noise ratio is essentially constant versus duty cycle. The disadvantage of this technique is that there is a lower limit to measurable pulse widths. As shown in Figure 12.9, as the pulse width becomes narrower, the spectral energy spreads out—once enough of the energy is outside the bandwidth of the receiver, the instrument cannot detect the pulses properly.

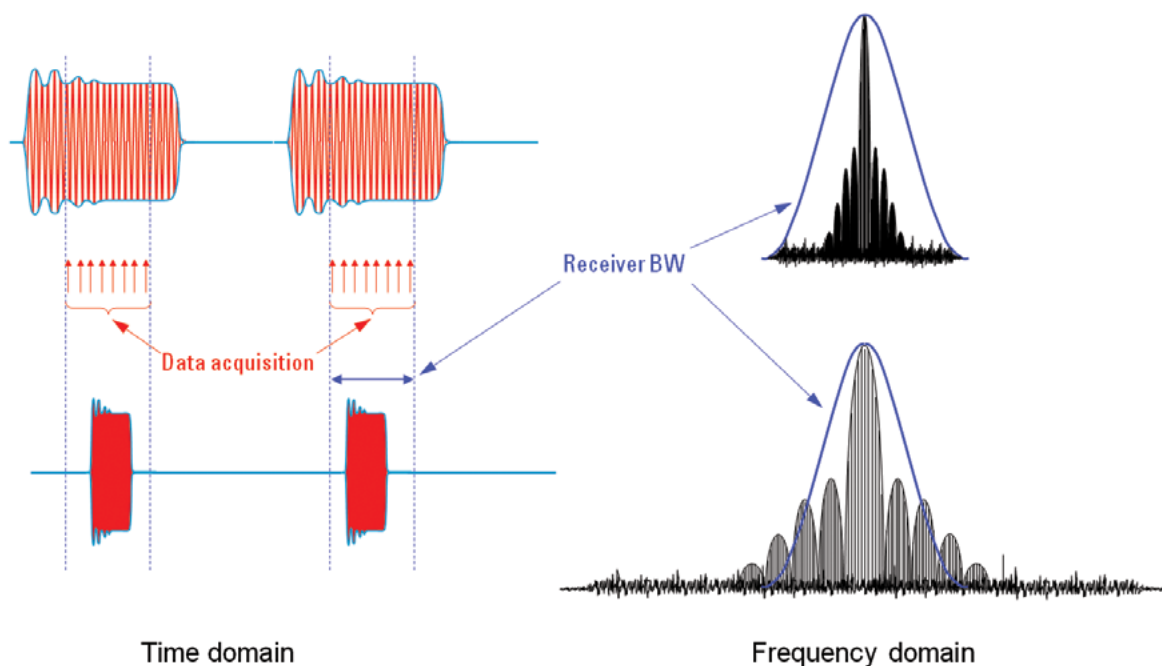

Figure 12.9. Pulse width and receiver bandwidth with wideband detection in time and frequency domain

Narrowband detection is used when most of the pulsed-RF spectrum is outside the bandwidth of the receiver. In other words, the pulse width is narrower than the minimum data acquisition period with the widest available receiver bandwidth. With this technique, the entire pulse spectrum is removed by filtering except for the central frequency component, which represents the frequency of the RF carrier. After filtering, the pulsed-RF signal appears as a sinusoid or CW signal. With narrowband detection, the analyzer samples are not synchronized with the incoming pulses (therefore no pulse trigger is required), so the technique is also called asynchronous acquisition mode. Usually, the PRF is high compared to the IF bandwidth of the receiver, so the technique is also sometimes called the “high PRF” mode.

Keysight has developed a novel way of achieving narrowband detection using wider IF bandwidths than normal, by using unique “spectral nulling” and “software gating” techniques. These techniques let the user trade dynamic range for speed, with the result almost always yielding faster measurements than those obtained by conventional filtering.

The advantage to narrowband detection is that there is no lower pulse-width limit, regardless of how broad the pulse spectrum is, most of it is filtered away, leaving only the central spectral component. The disadvantage to narrowband detection is that measurement dynamic range is a function of the duty cycle. As the duty cycle of the pulses becomes smaller (longer time between pulses), the power of the central spectral component becomes smaller, resulting in less signal-to-noise ratio as shown in Figure 12.10. Using this method, the measurement dynamic range decreases as the duty cycle decreases. This phenomenon is often called “pulse desensitization” and can be expressed as $20 \cdot \log(\text{duty cycle})$ in dB. Modern VNAs employ several unique features to minimize this effect, resulting in considerably less degradation in dynamic range.

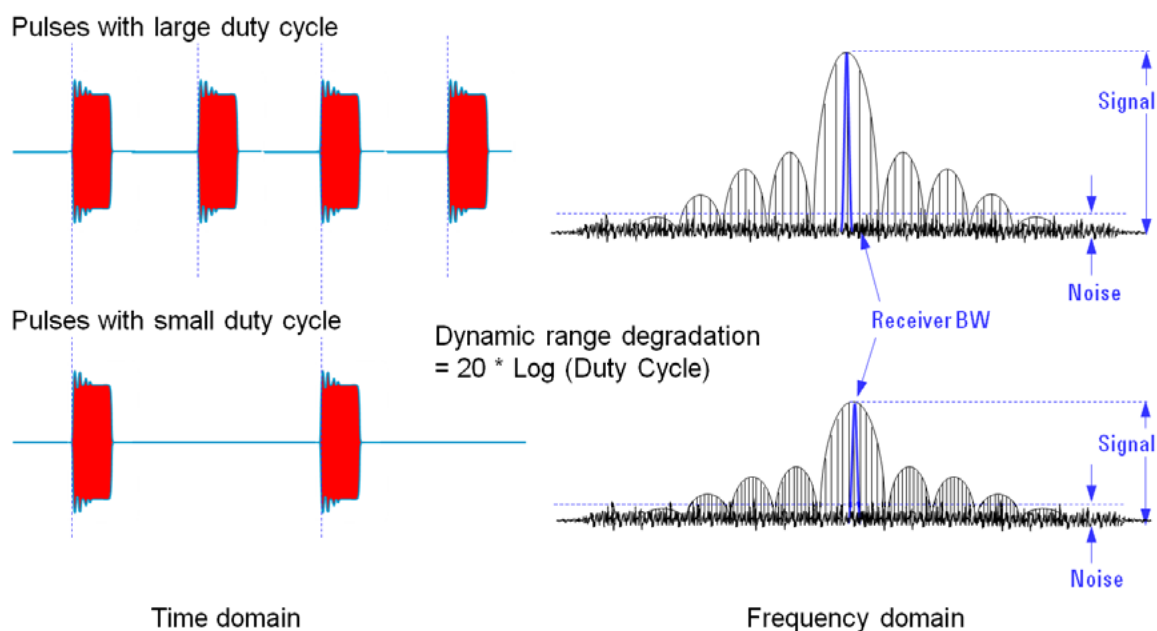

Figure 12.10. Duty cycle (time domain) versus signal-to-noise ratio of center spectrum (frequency domain)

In conclusion, testing with pulsed RF stimulus is very important for radar and electronic warfare systems. Modern network analyzers utilize two different detection schemes, each with advantages and disadvantages. Both wideband and narrowband detection can be used for point-in-pulse and pulse-profile measurements. Pulse-to-pulse measurements require wideband detection. Although wideband detection has traditionally been the more widely used technique, narrowband detection is a powerful alternative for analyzing pulsed-RF signals. Keysight's unique spectral nulling technique improves measurement speed considerably by using wider IF bandwidths. For radar and EW applications, narrowband detection offers a superior dynamic range and speed compared to past methods. With narrowband detection, there is no lower limit to pulse widths. Keysight's PNA vector network analyzers offer built-in pulse modulators and pulse generators providing a fully integrated solution for millimeter-wave pulsed-RF measurements.

Reduce Measurement Uncertainty

RF measurements are extremely sensitive. Test cables, connectors, and fixtures affect the measurement. You want to characterize the DUT; not the DUT and the cables connecting it to the network analyzer.

By default, network analyzers consider the DUT everything beyond the test ports. This consideration means the network analyzer's reference plane is at the test ports. Everything beyond the reference plane is included in the measurement.

The two most common methods of calibration are Thru, Reflect, Line (TRL), and Short, Open, Load, Thru (SOLT). These methods are different combinations of impedance and transmission measurements used to characterize the cables and fixtures for calibration.

These calibration techniques involve connecting standards with known properties to the measurement setup in place of the DUT. The network analyzer can apply corrections for cables and connectors by comparing what it measures to the values of the standards.

Traditionally, calibration is performed with mechanical standards. Operators would individually make each connection and let the instrument take a measurement. Full two-port calibration requires seven mechanical connections. This process is time-consuming and creates possibilities for user error.

Electronic calibration modules can replicate the different types of loads with just one connection. Electronic calibration is fast, repeatable, and limits wear on connectors.

CalPod calibration refresh modules are in-situ devices that can remove the effects of environmental variations in test cables, connectors, adaptors, and switch matrices to re-establish a valid calibration at the measurement plane, assuring your device's performance is not affected by these other environmental variations. Easily refresh a calibration at the push of a button, without removing the DUT, and without the physical connection of standards.

De-Embedding Fixture Effects

Many of today's devices do not have coaxial connectors and are put in fixtures to measure them in a coaxial environment. Accurately removing the effects of the fixture is required to get a good measurement of the DUT. Complicated modeling in EM simulation software or multiple calibration standards fabricated on board were needed, adding complexity and expense.

Powerful, fast, and accurate automatic fixture removal (AFR) can handle a variety of measurement needs such as:

- Single-ended and differential devices
- The left and right side of the fixture can be asymmetrical
- Through lengths can be specified or determined from open or short measurements
- Band-pass time-domain mode for band-limited devices
- Extrapolation to match DUT frequency range
- Power correction compensates for fixture loss versus frequency
- De-embed files can be saved in a variety of formats for later use in PNA, ADS, and PLTS

Keysight AFR is the fastest way to de-embed a fixture from the measurement.

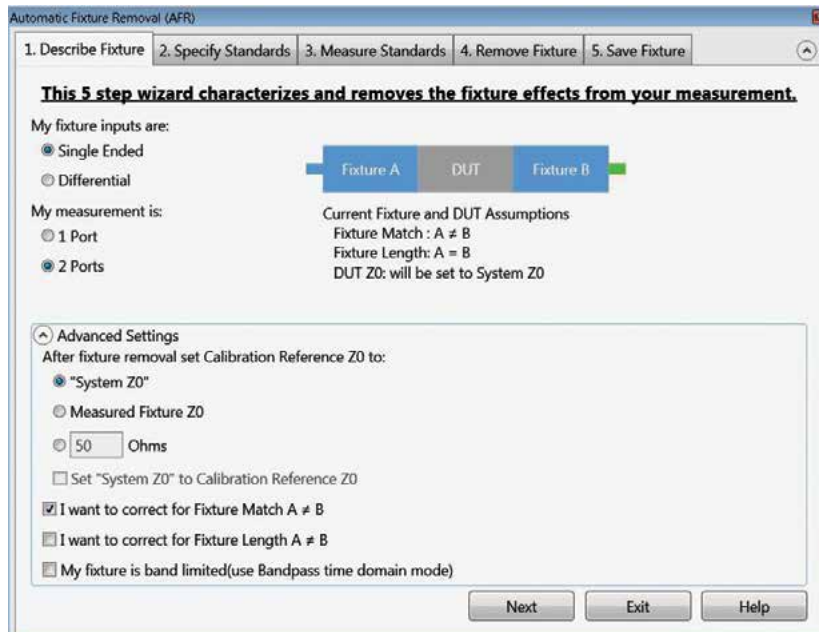

Figure 12.11. The S93007B five-step wizard guides you through the process to characterize your fixture and removes it from your measurement.

Simplifying Multiport Measurements

Modern devices are highly integrated requiring test and validation of devices with more than four ports. Radar and EW subsystems such as RF transmit receive modules (TRM) and phased array antennas require multiport characterization for all components. The need for multiport tests accelerated the development of switch-based solutions for traditional vector network analyzers (VNAs). When switch-based solutions were not adequate to keep up with the multiport test, the VNA itself was re-imagined and optimized for the multiport test.

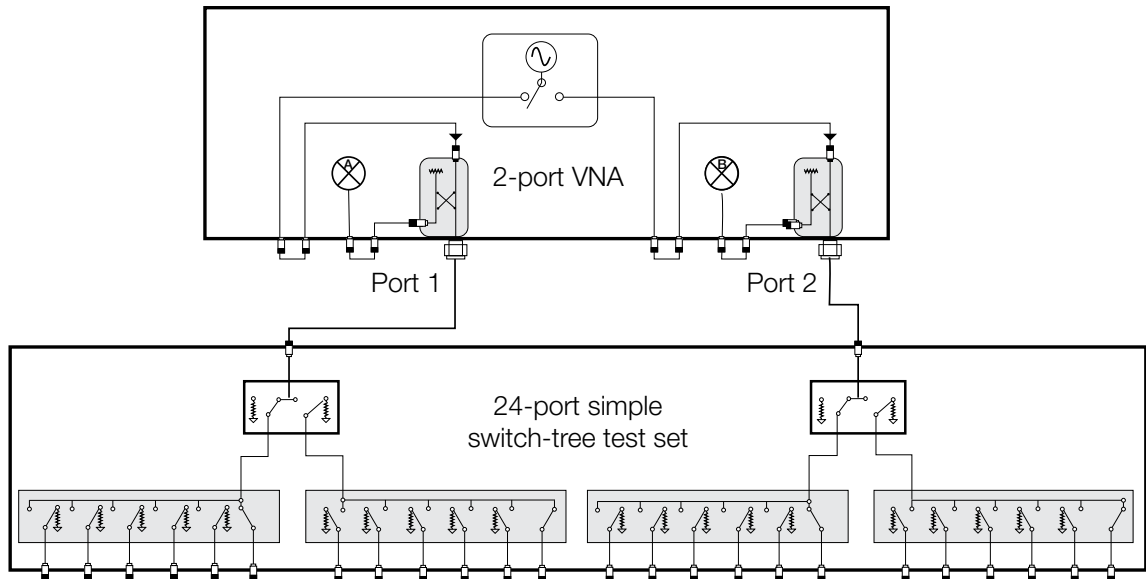

Figure 12.12. VNA with simple switch test set

High-volume tuning and testing of multiport devices can be greatly simplified by using a multiport network analyzer, or a multiport test set with a traditional two-port analyzer.

A single connection to each port of the device under test (DUT) allows for complete testing of all transmission paths and port reflection characteristics. Multiport test systems eliminate time-consuming reconnections to the DUT, significantly increasing efficiency. Furthermore, the risk of misconnections is lowered, operator fatigue is reduced, and the wear on cables, fixtures, connectors, and the DUT is minimized.

Full crossbar switching test sets measure between every port of a device as well as apply a load termination to unused ports. The full crossbar setup offers complete measurements between each of the ports but also introduces new challenges. Each of the six test ports in Figure 12.13 has two possible 1x6 switches to use as a load termination. The switch used for termination on each port varies depending on which ports are active. The varying termination of the ports makes full N-by-N calibration difficult because you need to calibrate for every case.

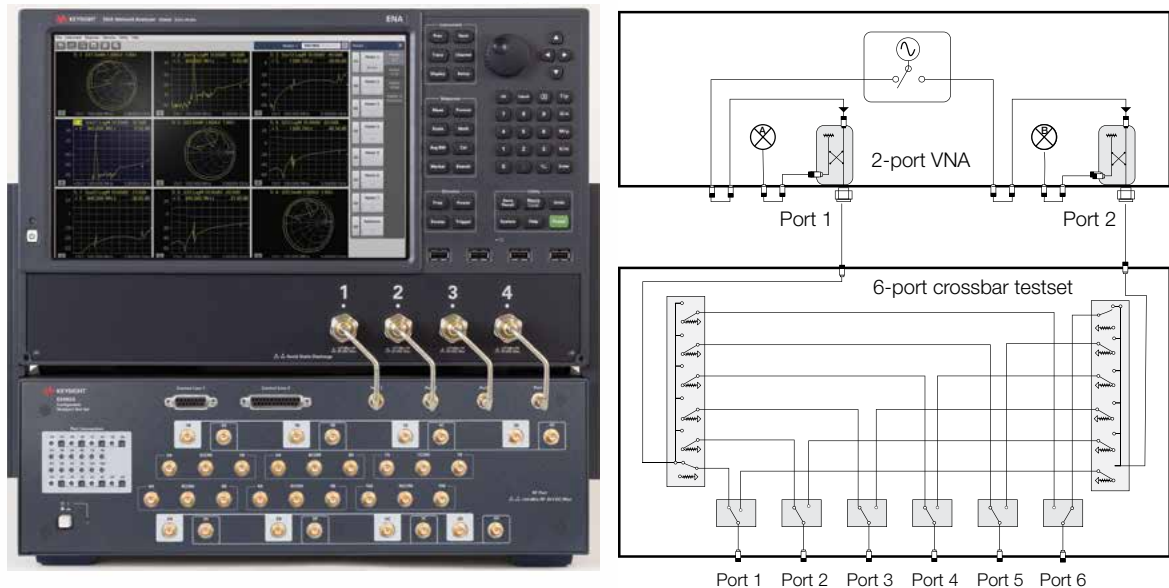

Figure 12.13. Full crossbar test set

External switches significantly affect measurement performance. The switching hardware is beyond the VNA's directional couplers that sample the test signal. Interference from the switching hardware creates a mismatch between the signal reaching the DUT and what the VNA measures. Calibration can help, but a switch matrix can never achieve the dynamic range, temperature stability, and trace noise performance of a standalone VNA.

Switch matrices provide a low-cost solution for multiport testing, but require significant operator intervention for setup, calibration, and adjusting configurations. Modern multiport devices demand faster and more accurate measurements than a switch-based solution.

True multiport setups maintain their measurement performance no matter how many ports you use. As frequencies trend higher and margins for error shrink, your test setup's measurement performance can significantly impact your yield.

Removing switches from multiport measurements does more than speed up the measurements. Setups without switches provide full VNA measurement performance. Attenuation from the switches degrades the dynamic range of switch-based multiport measurements, particularly at higher frequencies. By 20 GHz, switch-based solutions retain only half the dynamic range of multiport solutions.

The multiport VNA makes sweeps quickly due to the superior dynamic range of multiport VNAs. The attenuation of the switches in a switch-based system degrades dynamic range, especially at higher frequencies. The consistently wide dynamic range of a multiport VNA means you can use a wider IF bandwidth and capture your sweeps faster. Making fast measurements at higher frequencies becomes crucial to keep up with the trend of higher data rates in both high-speed digital and RF.

Multiport setups require significant calibration time. Switched test sets with solid-state switches are easily affected by temperature and must undergo frequent calibration to ensure accurate measurements. Calibration downtime drastically impacts throughput; a system with longer calibration intervals reduces your test time and your cost of test.

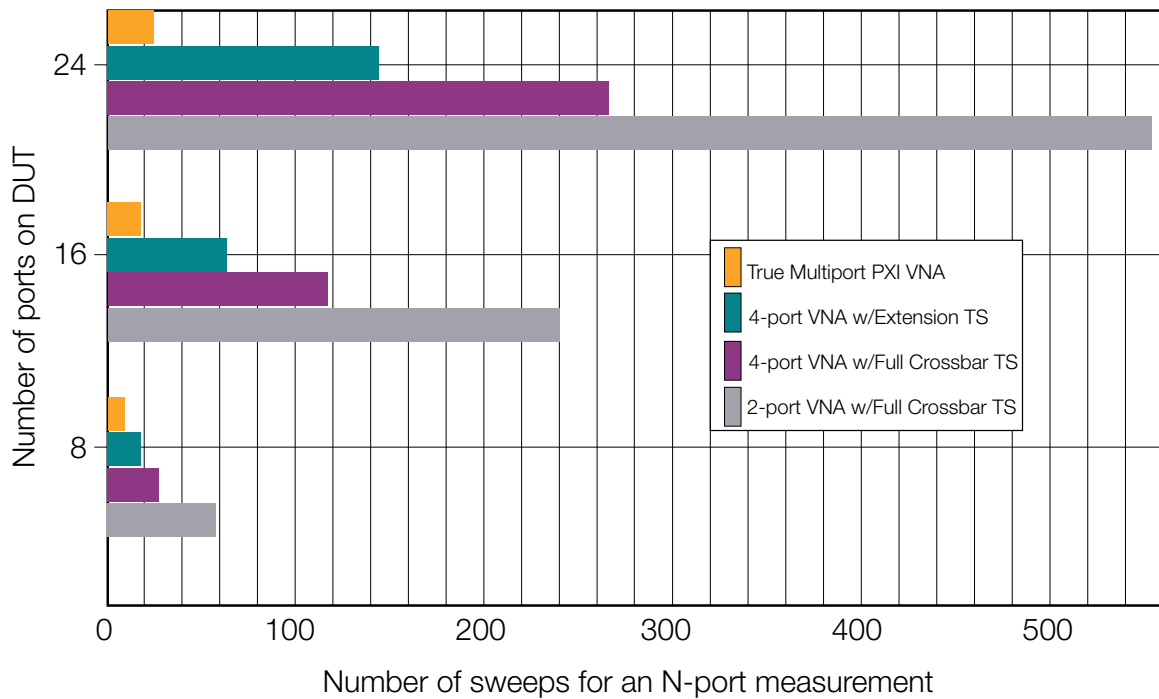
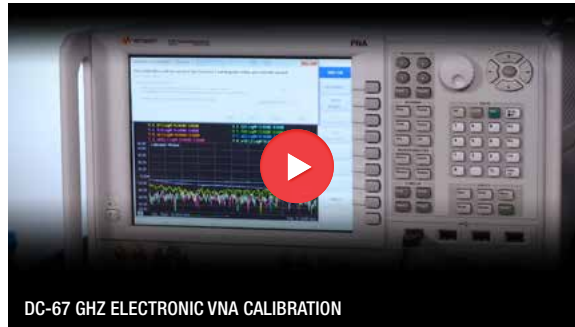
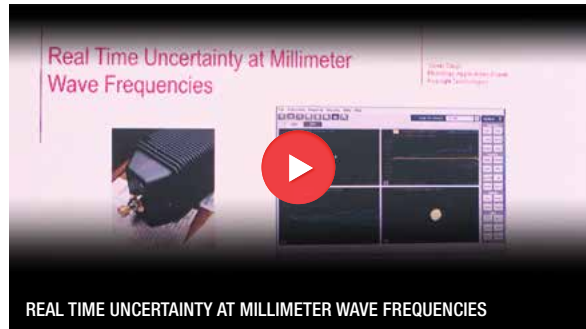
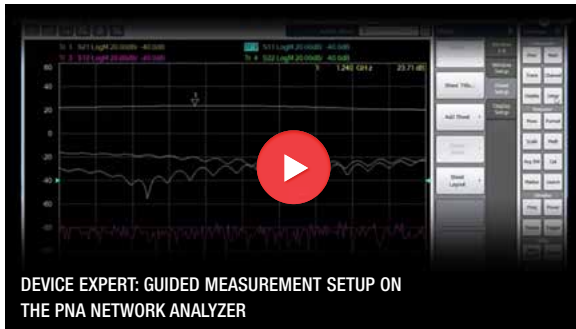

Figure 12.14. Sweeps required for multiport devices

A multiport VNA significantly reduces your test time to give you highly accurate measurements on multiport devices. The flexible modular configuration, fast measurement times, and high performance make VNAs the right tool for multiport testing. VNAs with up to 50 ports on a single chassis has the flexibility and performance to take on the toughest multiport challenges.



<https://www.keysight.com/see/radar-ew-component-test>



Chapter 13

Characterizing Frequency Translating Devices

Frequency-translating devices like upconverters and downconverters are one of the fundamental components in every RF or microwave transceiver chain and play fundamental roles in the transmit and receive chains of all defense systems, ranging from EW, ECM, ESM, ELINT, and SIGINT receivers, to satellite terminals and transponders, and radar systems. Radar, EW, and satellite RF systems require frequency converters or mixers with specified and well-controlled amplitude and group delay response. These key components present unique measurement challenges because they exhibit both desired and undesired linear and non-linear behavior. There are several measurements needed to fully characterize frequency-converting devices.

- Transmission measurements include RF to IF transfer function viz. conversion loss or gain, group delay, derivation from linear phase, and port to port isolation.
- Reflection measurements including return loss and VSWR.
- Measurements that characterize the distortion added by the conversion process include intermodulation distortion, conversion compression, and undesired mixing products.

A radio receiving system requires that the mixers within it have well-controlled amplitude, phase, and group-delay responses. Due to the nature of the required measurements, a stimulus-response ratioed measurement technique, such as S-parameter analysis, is ideal for most of the above measurements. Unfortunately, since these components have different input and output frequencies traditional S-parameter and network analysis techniques used for non-frequency translating devices are not valid.

Test Methodology

Vector network analyzers are an important measurement tool for characterizing the magnitude, phase, group delay, impedance, linearity, and isolation performance of high-frequency components. To accomplish this, a network analyzer provides a stimulus source, signal-separation devices, receivers for signal detection, display/processing circuitry, and algorithms for reviewing results. The hardware architecture of the PNA Series network analyzer as shown in Figure 13.1 uses narrowband mixer-based receivers. However, since the output is different from the input frequency for frequency converting devices, this tuned-receiver technique needs to be modified. To make these measurements possible the receivers must be independently tuned to a fixed offset from the stimulus.

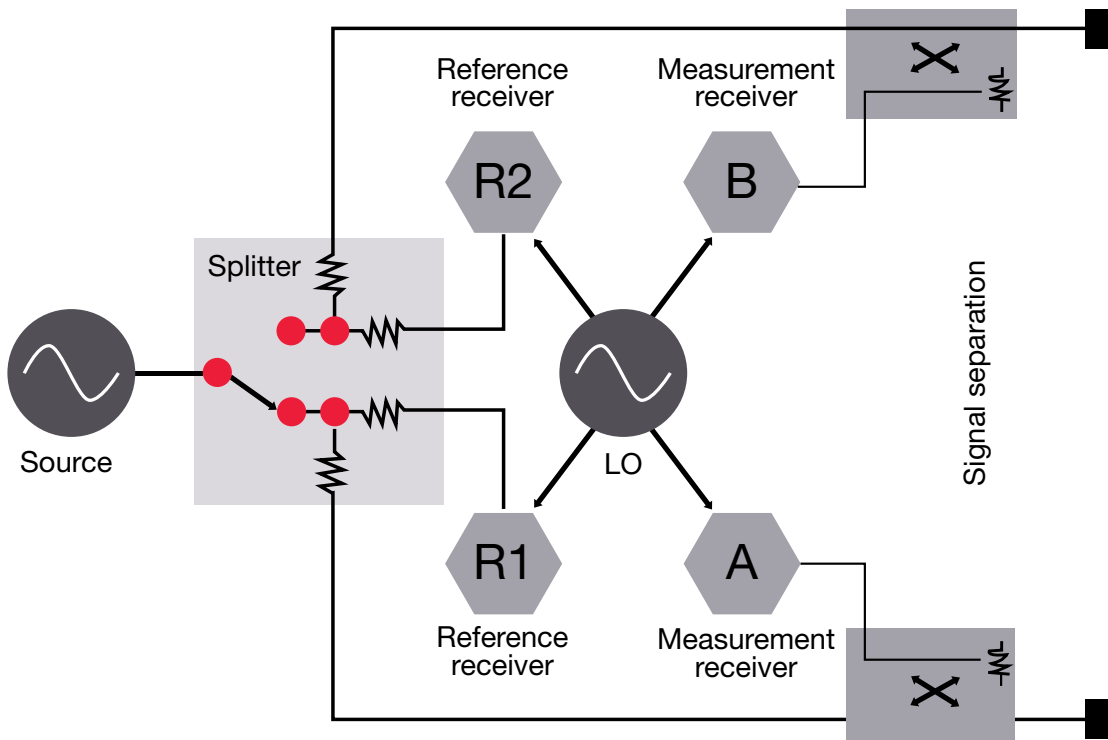

Figure 13.1. General network analyzer block diagram

This technique is referred to as frequency offset and is an option on many vector network analyzers. This requires additional hardware and firmware control. Traditional techniques used for calibration and error correction are not valid with frequency-offset hardware changes because the error terms cannot be maintained in a constant phase relation. A modified frequency-offset error model is needed to describe the interactions of error signals in this environment. Frequency Offset Mode (FOM) provides the capability to have the VNA Sources tuned to frequencies that are different (offset) from the VNA Receivers. Further, modern mixers and frequency converters also push the limits of a network analyzer's capabilities. Getting consistent measurements for operating bandwidths as wide as 3.2 GHz at 29 GHz often requires averaging multiple sweeps to reduce the noise.

To meet the demands of modern high-frequency device testing, Keysight introduced in its PNA and PNA-X Series of network analyzers to use the same direct-digital synthesis (DDS) technology as high-end signal generators. DDS signal sources provide consistent and clean signals for unmatched performance in sensitive applications. The new sources with DDS with very low phase noise make phase measurements more stable and improves the measurement performance of some applications that require stable phase noise measurements: scalar-mixer calibration (SMC) + phase.

The frequency converter application (FCA) is an option offered with the microwave PNA Series network analyzers and is designed to address both the calibration and measurement difficulties for testing frequency converter devices. FCA offers an easy-to-use graphical user interface and advanced calibration techniques, including the scalar-mixer calibration, scalar-mixer + phase (SMC+Phase), and vector-mixer calibration (VMC).

SMC can be used to characterize the conversion loss magnitude and reflection parameters of mixers. A conversion loss magnitude measurement is a ratio of the output power (at the output frequency) to the input power (at the input frequency). The calibration is based on a combination of port and device match characterization and power meter measurements. With SMC, the input and output power levels are accurately determined by calibrating the network analyzer with a power meter, thereby transferring the accuracy of a power meter to the network analyzer. By using the network analyzer's one-port calibration ability, the port and device input and output reflection coefficients are measured. Using the known vector reflection coefficients of the test port, the device, and the power sensor, SMC corrects for mismatch loss. Since SMC is referenced to a traceable standard (power sensor/meter measurements), it provides the best-specified measurement of conversion loss magnitude.

VMC offers measurements of conversion loss magnitude, phase, and absolute group delay by using a combination of calibration standards (such as short, open, load, or ECal), and a "calibration mixer/IF-filter" pair during calibration. Vector-mixer calibration is based on a modified two-port error model, however, the steps and standards used to determine the error terms differ from the traditional two-port calibration. In the case of a frequency-translating device, the procedures differ because the input and output frequencies are different and additional calibration steps are required. In VMC, the calibration standards are still used to determine the directivity and match error terms. A "calibration mixer/IF-filter" pair is used as a new standard to determine the transmission tracking term. A calibration mixer that is assumed to be reciprocal, is characterized for input match, output match, and conversion loss (both magnitude and phase).

SMC+Phase combines the simplicity of SMC with the phase and delay measurement capability of VMC and eliminates the need for reference and calibration mixers for phase or group delay testing. SMC+Phase can also be used to measure converters with embedded LOs that are difficult or impossible to access. This technique significantly simplifies and reduces the cost of the measurement test setup.

As explained earlier, SMC is the most accurate way to measure conversion loss and gain. It corrects for mismatch errors during calibration and measurements by combining one port and power-meter calibrations. The technique is simple to set up and calibrate and requires a power meter during calibration along with the usual open, short, load, and thru standards. SMC corrects for DUT mismatch during transmission measurements by taking advantage of the VNA's ability to measure its source and load match during calibration as well as the DUT's input and output match. Two techniques are shown in Figure 13.2.

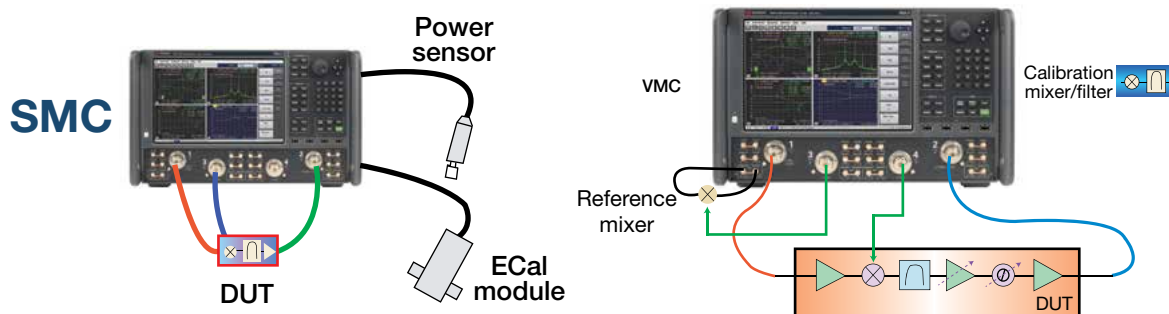

Figure 13.2. SMC + VMC for frequency translating devices

The VMC technique delivers the most accurate phase and absolute group delay measurements, calibrates the test system's transmission phase response, and provides mismatch correction at the input and output of the DUT. However, the technique has several inherent drawbacks. It is more complicated and requires more external components than SMC as two additional mixers are needed for reference and calibration. VMC uses a characterized mixer as a calibration thru standard along with the usual open, short, and load standards, and removes magnitude and phase errors for transmission and reflection measurements. An external reference mixer is used as a phase reference but is not needed for phase locking the source and receivers with a frequency offset, as offset sweeps are achieved with the instrument's internal sources. As both calibration techniques perform corrections for mismatches, external attenuators are rarely needed. While VMC provides the ability to evaluate deviation from linear phase and absolute group delay, mixers that match the frequency range of the DUT are harder to obtain above 26.5 GHz as are filters with acceptable performance. In addition, many mixers may be required to evaluate DUTs with diverse frequency plans, so several calibrations must often be performed to cover all bands.

The SMC+Phase technique, as shown in Figure 13.3, uses simple setup and calibration, requires no external signal source or reference and calibration mixers, provides the most accurate conversion-loss/gain and phase/delay measurements, and removes mismatch errors during calibration and measurement. It replaces VMC for most frequency converter measurement applications. In contrast to VMC that uses ratios of test and reference signals at the same frequency (thus the required reference mixer), the SMC+Phase technique ratios single-receiver phase measurements performed at the DUT's input and output. It also replaces the calibration mixer with a comb generator as a phase standard, and magnitude

measurements are performed the same way as SMC, using a power sensor as a calibration standard. By eliminating the reference and calibration mixers, SMC+Phase simplifies and reduces the cost of the converter measurement system.

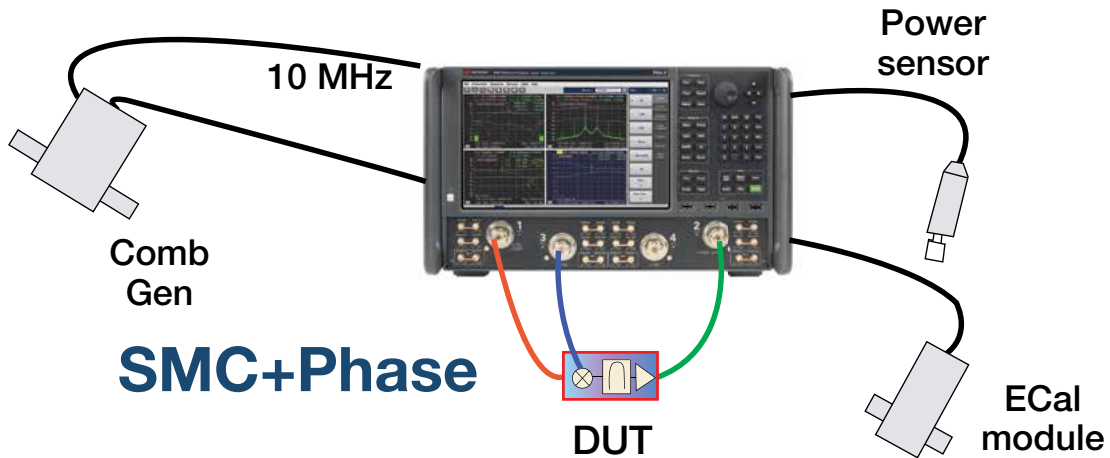

Figure 13.3. Setup for SMC+Phase

The phase-measurement technique employed by SMC+Phase relies on the phase coherency of the signal sources in the instruments' DDS architecture to eliminate the reference mixer Figure 13.4. This is an advantage of the PNA and PNA-X over other VNAs that do not have the new DDS sources. The PNA and PNA-X feature extremely low phase noise and spurious emissions to help you measure complex components faster. DDS sources maintain relative phase coherence across a frequency sweep by digitally incrementing the phase accumulators and by employing synchronous IF detection and digital signal processing.

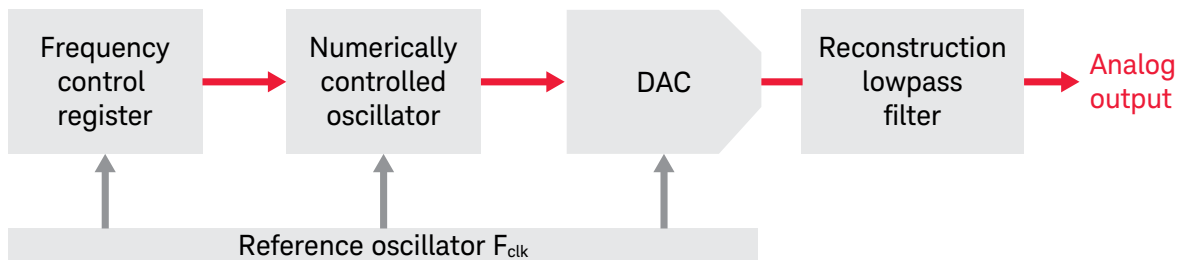

Figure 13.4. Direct Digital Synthesis

In the first step of this new method, the VNA receivers are calibrated for absolute power and phase relative to the test ports without test cables or other system interconnects attached. The second step is a simple S-parameter calibration that removes the effects of test cables, adapters, attenuators, and wafer probes. The comb generator creates a repetitive, negative-going impulse in the time domain, which provides a broadband phase-calibrated frequency spectrum (i.e., a “comb” of signals) that is used to calibrate the phase of the VNA receivers (Figure 13.5).



Figure 13.5. Comb Generator

The calibration performed during the first step adjusts the VNA receivers for absolute power using a power sensor and phase using a comb generator. It is typically performed directly at the reference plane of the instrument’s test ports or with adapters connected to them. This eliminates the effect of test cables, making the calibration more accurate and repeatable. Calibration is typically performed over the full frequency range of the instrument and can be performed infrequently because of the instruments’ stability.

The S-parameter calibration performed in the second step includes the system interconnect hardware that was not included in the first step and is performed at the end of the test cables, adapters, or wafer probes that connect to the DUT. For coaxial calibrations in which the ECal module connectors match those of the DUT, this calibration can be done as a single step.

Advanced Parameters Test Methodology

Embedded LOs are common in certain types of converters and transponders. As a result, it is impossible to access the DUT's LO or its time base and thus also impossible to make the necessary connections to provide coherent frequency synchronization of the VNA and the transponder (Figure 13.6). Therefore, VNAs have traditionally not been used for these measurements, which has hindered efforts to reduce the time required for transponder characterization. Keysight has created a way to circumvent this problem that makes it possible to make very accurate VNA-based converter measurements in these situations. There are four basic obstacles that must be surmounted to make VNA-based measurements of embedded LOs possible. The first is frequency stability, which is not an issue for most transponders, as their LOs are locked to highly stable crystal oscillators and have low phase noise.

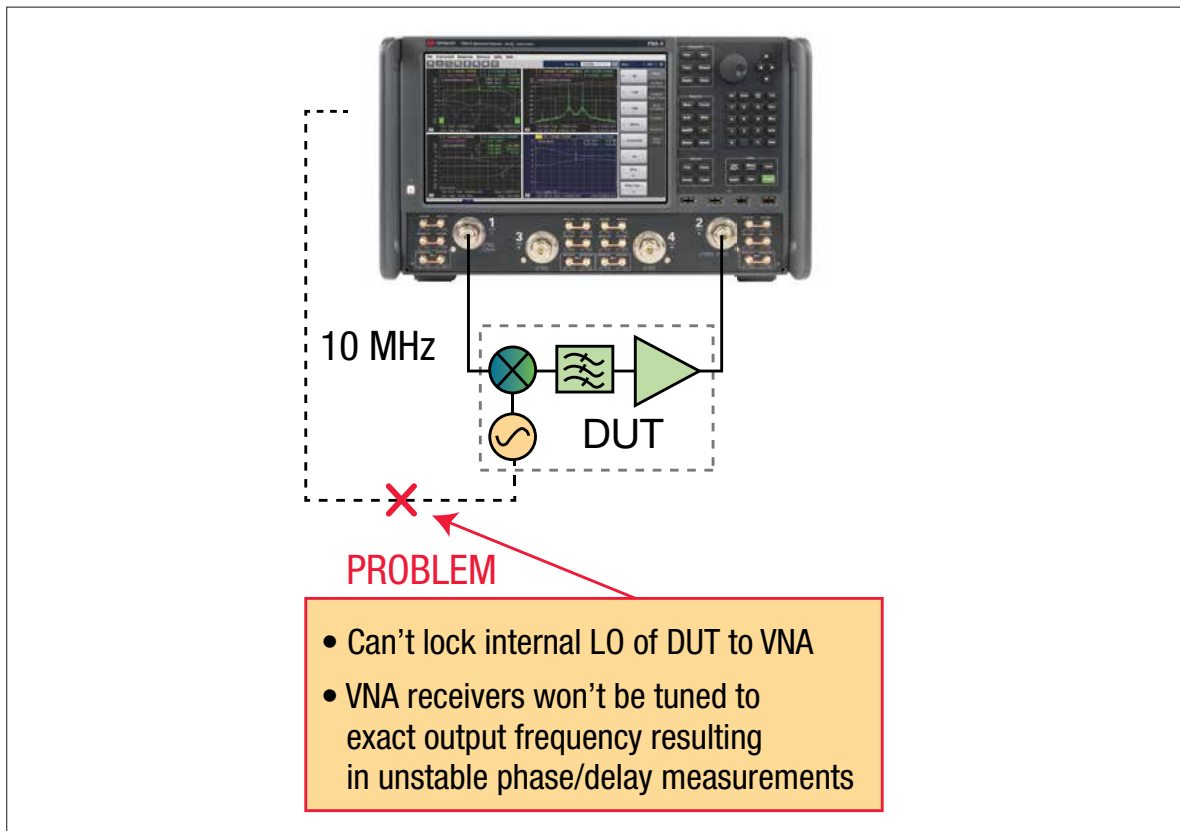

Figure 13.6. Embedded LOs, a fact of life

The second issue is establishing frequency coherence because the narrowband VNA receivers must be tuned to frequencies that exactly match the output frequencies of the DUT. The VNA's LO must also be stable enough relative to the DUT's LO to ensure that errors caused by the non-ratioed phase are not excessive. The next issue is phase stability that arises because even when the frequencies are the same there will be sweep-to-sweep variations in absolute phase response caused by the architecture of the instrument. Fortunately, phase can be normalized at each sweep to an arbitrary phase reference so that averaging can be used just as effectively as with a common time-base.

Finally, as the phase noise of the LOs in the VNA and DUT cannot be "ratioed out", averaging and smoothing can be used to lower the noise of the group delay measurements. To establish the appropriate pseudo-coherent phase relationship between the DUT and the test instrument, the PNA or PNA-X breaks down the measurement of the converter's effective LO into coarse and fine measurements. This two-step approach quickly achieves the needed frequency accuracy. Coarse tuning is achieved by first setting the RF stimulus to an appropriate CW frequency within the defined input frequency band, and then the instrument calculates the output frequency corresponding to the input frequency and the nominal value of the DUT's LO.

The instrument's internal receivers are swept around the expected center frequency of the DUT's output. The difference between the peak of the actual signal and the expected signal (based on the nominal value of the DUT's LO) gives a frequency-offset value for adjusting the nominal LO value of the mixing plan. The VNA is then tuned very close to the DUT's actual output frequency. The frequency span of the coarse receiver sweep can be set by the user up to 10 MHz. The coarse-tune process gets the instrument close to the desired output frequency but not close enough to stop phase slippage between the VNA and the DUT. The necessary frequency accuracy can be obtained by taking a different measurement approach for the fine sweep. Once the coarse offset is applied, the PNA performs a ratioed phase-versus time sweep between the DUT and test receivers at a fixed input frequency and with the test receiver fix-tuned to the output frequency of the DUT derived with the coarse sweep. Any small residual frequency offset will show up as a linear phase change versus time. The slope of this phase change can be accurately estimated, which gives the fine offset value. This fine-tuning process can be repeated multiple times to get a good sub-hertz estimate of the DUT's LO frequency. Minimizing the phase shift versus time until the phase response has a flat slope over the measurement period provides a pseudo-locked condition and places the two local oscillators in a fixed phase relationship. This method is much faster than performing a narrowband sweep of the VNA's receivers with many data points. Both coarse and fine-tuning can be performed at every sweep of the group delay measurement, creating a coherent relationship between the instrument and the DUT.

Apart from the frequency response of the frequency translating devices, they need to be characterized for other advanced parameters too, like IMD, compression, noise figure, modulation distortion, etc. Complex measurements may require multiple instruments, but the 3rd source eliminates the need for an external signal generator for mixer IMD measurements (Figure 13.7).

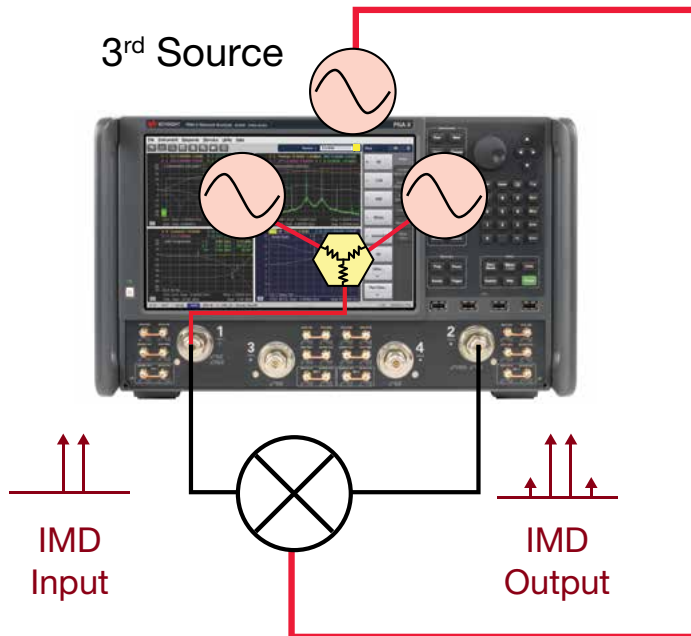

Figure 13.7. Mixer IMD measurement

FCA applications on the VNA provide the scalar mixer/converter plus phase (SMC+Phase) measurement class that provides fully calibrated conversion gain/loss, relative phase, and absolute group delay measurements of mixers and converters without the need for reference or calibration mixers. Eliminating the calibration mixer requires a U9391C/F/G comb generator. FCA provides an intuitive and easy-to-use user interface for setting up mixer and converter measurements, with single or dual conversion stages. It can control the analyzer's built-in source(s) as well as external signal generators for use as LO signals. Supported external sources include the Keysight sources as well as other SCPI-controlled signal generators.

VNA firmware supports numerous measurement classes for the complete characterization of frequency translating devices. (Figure 13.8).

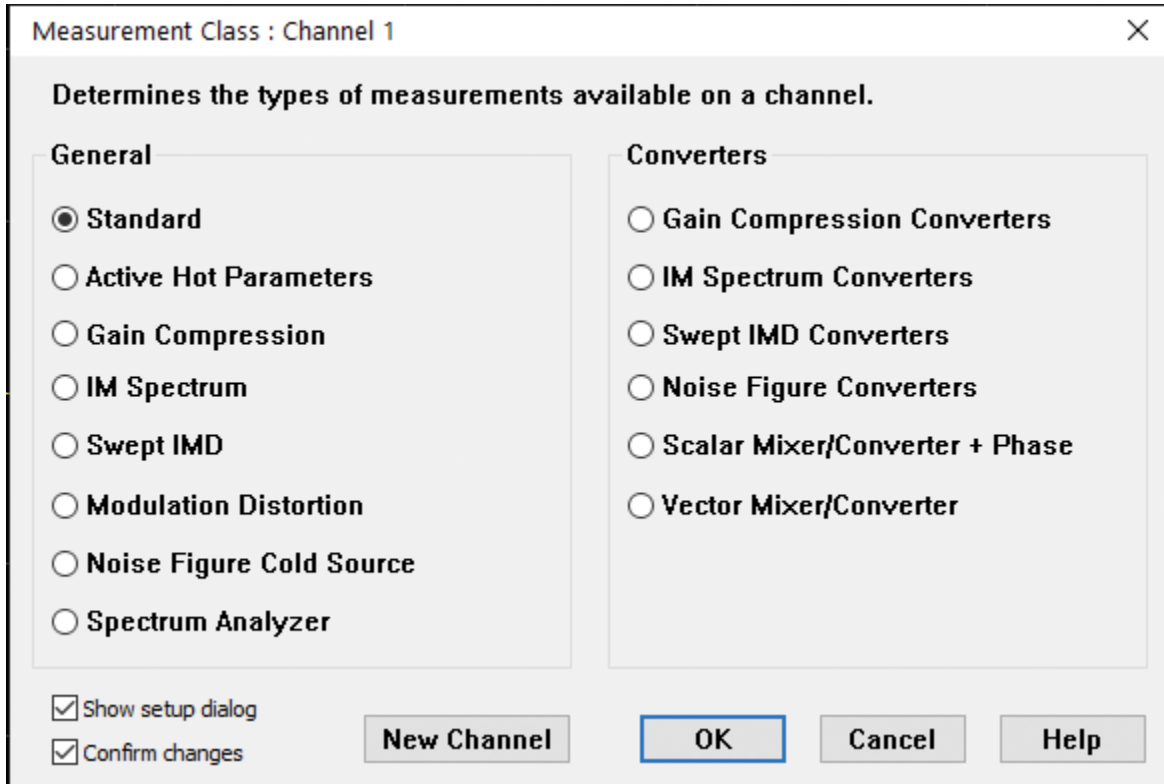

Figure 13.8. Measurement classes on PNA series VNA

Further, when measuring the noise figure of frequency converters, source power calibration is performed which levels the source power versus frequency. The leveled power is later used to calibrate the standard receivers for absolute power measurements, which is necessary for measuring the conversion gain (or loss) of frequency converters. This methodology is the same as is used in the SMC measurement class.

Keysight ENA, PXIe, and USB streamline VNA also offer advanced mixer calibration techniques: SMC, SMC+Phase, and vector-mixer calibration to test frequency translating devices.

Together these techniques represent significant advances in converter characterization that are likely to become the standard for the way these measurements are made by the radar and EW system designers.



Chapter 14 Expand Insight into Nonlinear Behavior and Modeling

When designing systems with high-power amplifiers, designers measured S-parameters using a vector network analyzer, loaded the results into an RF simulator, added other measured or modeled circuit elements, and then ran a simulation to predict system performance such as gain and power-efficiency under various loads. Since S-parameters assume that all elements in the system are linear, this approach does not work well when attempting to simulate performance when the amplifier is in compression or saturation, as real-world amplifiers often are. The errors are particularly apparent when simulating the combined performance of two cascaded devices that exhibit nonlinear behavior. While engineers may live with this inaccuracy, it invariably results in extensive and costly empirical-based iterations of the design, adding substantial time and cost to the design and verification process.

Testing today's high-power devices demands an alternate solution—one that quickly and accurately measures and displays the device's nonlinear behavior under large-signal conditions and provides an accurate behavioral model that can be used for linear and nonlinear circuit simulations. Nonlinear vector network analyzer (NVNA) and X-parameters provide a means to efficiently analyze and design active devices and systems under real-world operating conditions, reduce design cycles by as much as 50%, and providing valuable insight into device behavior with full nonlinear component characterization.

Amplifier characteristics depend on the impedance matching and need to be tested under actual drive power. The power delivered and the optimum load can be characterized with normal S22 S-parameter measurements in linear regions, but once the amplifier operates at high power, it goes into nonlinear regions, and the behavior cannot be predicted.

Active hot parameters are appropriate for amplifiers where the transistors are pre-matched and are used to verify that the matching is good and there are not any extraneous matching issues. The technique is significantly faster than other methods and provides a measure of the true Hot S22, the optimum match for maximum power, the value of the maximum power as well as the power delivered to 50 Ω . In summary, it provides the fundamental X-parameters of the amplifier. This capability can be added to PNA-X network analyzers with the S93110B Active Hot Parameters application.

Bare transistors, which require substantial impedance matching at fundamental and harmonic frequencies require testing with the nonlinear vector network analyzer and X-parameters - the mathematically correct extension of S-parameters to large-signal conditions. This provides a device-independent black-box framework whose coefficients are identifiable from a simple set of physical measurements on the device under test.

X-parameters are a fully nonlinear framework that provides both the magnitude and phase of the fundamental and harmonics. They can be cascaded in simulation and produce the correct behavior in mismatched environments. Researchers and designers can now measure match, gain, group delay, and more for driven components. The methodology can be extended to two-tone, multi-tone, frequency converter, and three-port mixer parameters.

The standard PNA-X is transformed into the NVNA with a minimum of external accessories and nonlinear firmware options. Core to this transformation is the nonlinear calibration process. Trust in the measured data is as important as the data itself. NVNA's state-of-the-art nonlinear calibration process provides vector calibrated amplitude and phase data traceable to the National Institute of Science and Technology (NIST). A simple three-step calibration process is driven by a graphical calibration wizard to remove any systematic errors and maximize accuracy.

Used in conjunction with PathWave design and simulation tools, X-parameters minimize design iterations, speed simulation, and deterministically model the nonlinear behavior of your active components. This can significantly reduce the time to market for component, module, and system design. Additionally, because Keysight's X-parameters are a measurement-based representation of the DUT, they can be used to distribute more complete device operating characteristics than traditional datasheets, and at the same time protect the device IP.

NVNA nonlinear measurements



ADS simulation and design

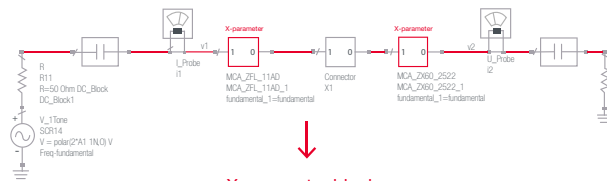

X-parameter blocks

X-parameters enable accurate nonlinear simulation under arbitrary matching conditions.

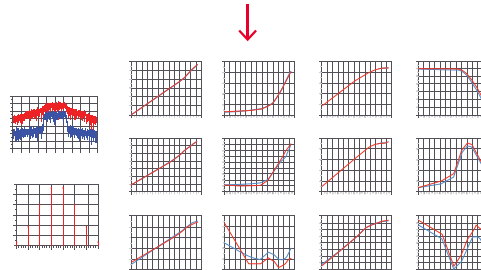

This allows prediction of component behavior in complicated nonlinear circuits.

Figure 14.1. Measure complete linear and nonlinear component behavior with the Keysight NVNA, and then accurately perform simulations and optimizations with Keysight's Advanced Design System.

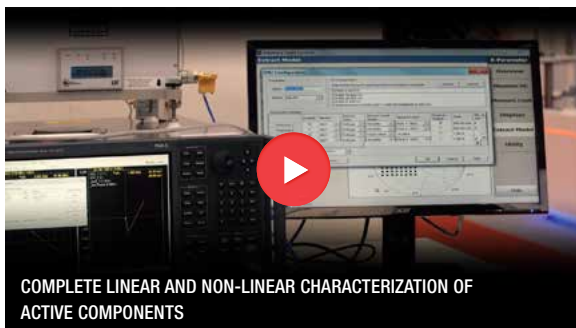

<https://www.keysight.com/see/radar-ew-component-test>



Chapter 15

Methods for Measuring the Dielectric Properties of Materials

Dielectric property is one of the fundamental electromagnetic properties of materials. It describes how a material interacts with an applied electromagnetic field. When electric and magnetic fields pass through a material, each can interact with that material in two ways:

- **Storage:** Energy may be exchanged between the field and the material, in a bi-directional (lossless) manner.
- **Loss:** Energy may be permanently lost from the field, and absorbed in the material (usually as heat).

Every material has a unique set of electrical characteristics that are dependent on its dielectric properties. “Materials” can mean just about anything. They are produced or used by many diverse industries. For example, the loss of a cable insulator, the impedance of a substrate for a microwave integrated circuit, or the frequency of a dielectric resonator can be related to its dielectric properties. The information is also useful for improving ferrite, absorber, and packaging designs.

Material Characterization

Material has a unique set of electrical and magnetic characteristics that are dependent on its electromagnetic properties. Accurate measurements of these properties can provide scientists and engineers with valuable information to properly incorporate the material into its intended application for more solid designs or to monitor a manufacturing process for improved quality control.

A dielectric materials measurement can provide critical design parameter information for many electronics applications.

Numerous techniques are adopted for material characterization. Here’s an overview of the techniques we will be discussing in this chapter.

1. **Parallel Plate (sometimes called capacitance method):** It uses a parallel plate capacitor, with the material in between. This method uses an impedance analyzer. It is typically used at the lower frequencies, below 1 GHz.
2. **Coaxial probe:** This method uses an open-ended coaxial probe, usually with a network analyzer. It is the easiest method to use for liquids, or soft semi-solids, although very flat hard solids can be measured as well. Keysight offers probes in the RF to microwave frequencies, 200MHz to 50GHz.
3. **Resonant Cavity:** This method uses a resonant cavity for the sample holder, and a network analyzer to measure the resonant frequency and Q of the cavity, both empty and with the sample present. From this, permittivity can be calculated. This method has the best loss factor resolution.
4. **Transmission Line:** This method can use a variety of transmission “lines” for sample holders with a network analyzer. Lines can be coaxial; waveguide and even free space are considered a transmission line technique. It is useful for a broad frequency range, from the low microwave region to mm-wave.

Each method has strengths and limitations that make it useful for a particular application. The choice of technique depends on many things like frequency of interest, required measurement accuracy, material properties (i.e., homogeneous, isotropic), the form of material (i.e., liquid, powder, solid, sheet); sample size restrictions, destructive or nondestructive testing, contacting or non-contacting test, measurement temperature.

Figure 15.1 provides a map of different measurement techniques according to the frequency range of operation and the MUT (Material Under Test) losses.

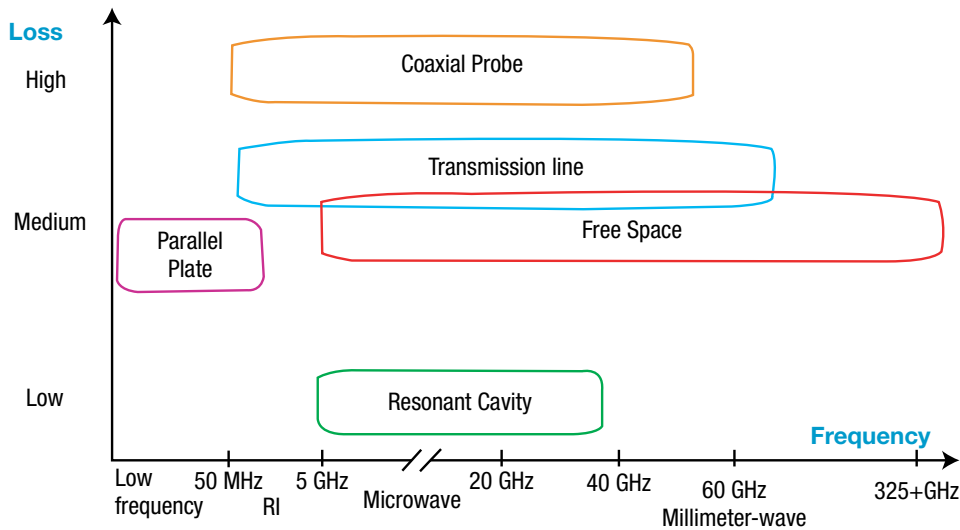

Figure 15.1. Material measurement techniques

Parallel Plate Technique

The parallel plate method also called the three terminals method in ASTM standard D15012, involves sandwiching a thin sheet of material or liquid between two electrodes to form a capacitor. The measured capacitance is then used to calculate permittivity, see Figure 15.2. In an actual test setup, two electrodes are configured with a test fixture sandwiching dielectric material. The impedance-measuring instrument would measure vector components of capacitance (C) and dissipation (D) and a software program would calculate permittivity and loss tangent.

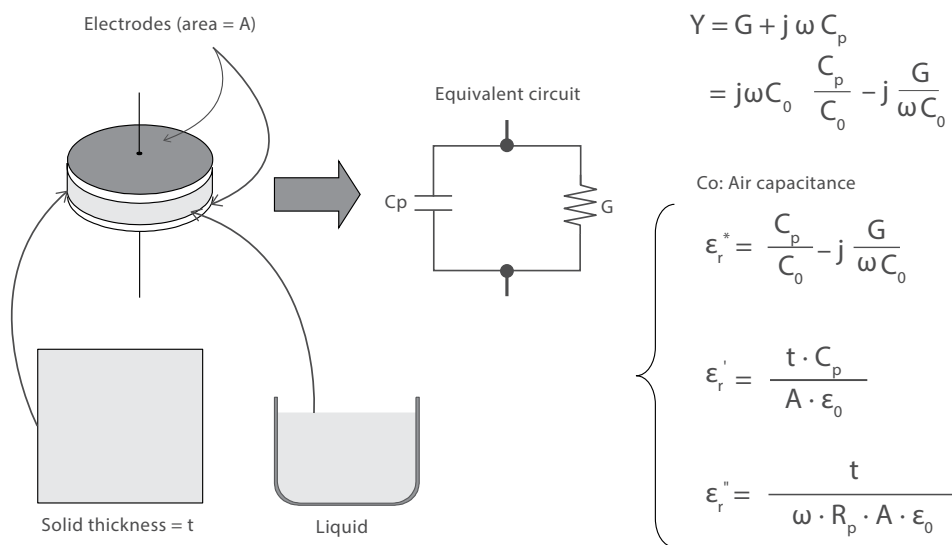

Figure 15.2. Parallel plate technique

The method works best for accurate, low-frequency measurements of thin sheets or liquids. A typical measurement system using the parallel plate method consists of an impedance analyzer or LCR meter and a fixture such as the 16451B and 16453A dielectric test fixture, which operates up to 1 GHz. The 16452A test fixture is offered for measuring liquids.

RF parallel plate provides ease of use and good accuracy for both dielectric and magnetic materials. However, the parallel plate method does not measure materials with magnetic properties.

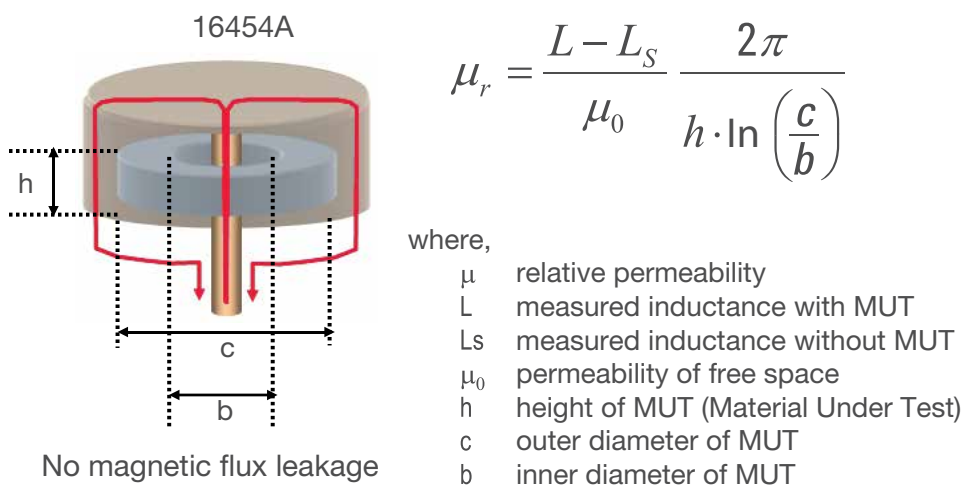

Figure 15.3. Measurement method for magnetic material

You should use the “inductance” measurement method to measure permeability. Relative permeability of magnetic material derived from the self-inductance of a cored inductor that has a closed-loop (such as the toroidal core) is often called effective permeability, see Figure 15.3. The conventional method of measuring effective permeability is to wind some wire around the core and evaluate the inductance with respect to the ends of the wire. This type of measurement is usually performed with an impedance analyzer. Effective permeability is derived from the inductance measurement result. The Keysight 16454A magnetic material test fixture provides an ideal structure for a single-turn inductor, with no flux leakage when a toroidal core is inserted in it.

Coaxial Probe Method

A typical coaxial probe system consists of a vector network analyzer, a coaxial probe, and software to calculate permittivity from calibrated S-parameter measurements. Keysight offers probes and software for these measurements.

The coaxial probe method works with Keysight N1501A dielectric probe hardware. Measurements are conveniently made by immersing the probe into liquids or semi-solids – no special fixtures or containers are required. Measurements are non-destructive and can be made in real-time. These important features allow the dielectric probe kit to be used in process analytic technologies. The open-ended coaxial probe

is a cut-off section of the transmission line. The material is measured by touching the probe to a flat face of a solid or immersing it into a liquid or semisolid. The fields at the probe end “fringe” into the material and change as they meet the MUT. The reflected signal (S_{11}) can be measured and related to ϵ_r .

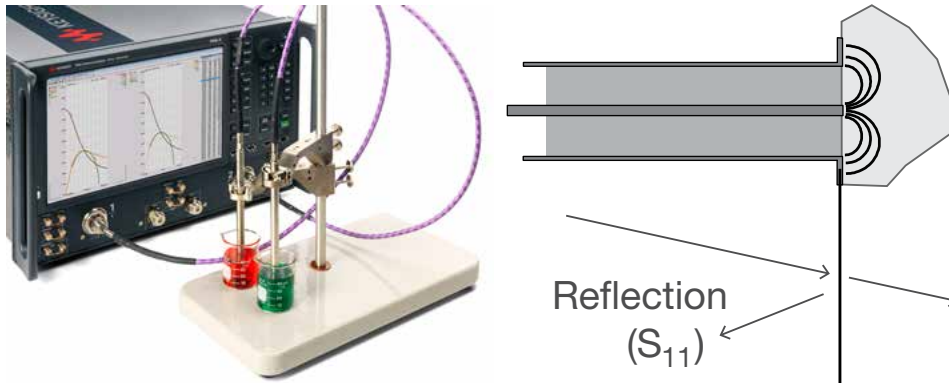

15.4. Coaxial probe method

Additionally, an automated electronic calibration refresh feature recalibrates the system automatically, in seconds, before each measurement is made. This virtually eliminates cable instability and system drift errors.

The coaxial probe method is convenient and operates over a wide 200 MHz to 50 GHz frequency range. It is not well suited to low loss materials, magnetic materials, or where high accuracy is desired. Keysight offers three probe designs. Each has unique strengths and limitations.

“High-Temperature Probe” has the lowest frequency coverage of all the probes. It can be used with an impedance analyzer down to 10MHz. The large flange makes it easier to measure solid materials.

“Slim Form Probe” is a low-cost consumable design. It is the lowest cost of all the probes. It is ideal for measuring materials that would destroy the probe, such as curing epoxy or cement. Because the tip is so narrow and the tip is not as flat as the other probes, it is not suitable for measuring hard solids.

“Performance Probe” combines rugged high-temperature performance with high-frequency performance all in one slim design. It withstands extreme temperatures like the high-temperature probe and covers up to 50GHz like the slim form probe. In addition, it is hermetically sealed on both ends making it ideal for applications that need sterile equipment. This probe can be autoclaved.

There are few assumptions while making this measurement. The technique assumes that the sample is semi-infinite or endless, or at least as far as the network analyzer can see. How far into the material the field extends depends on the material properties, the frequency of the measurement, and the dimensions of the probe. Air gaps between a solid and the probe tip, and bubbles in a liquid will cause errors. The sample is also assumed to be non-magnetic and isotropic.

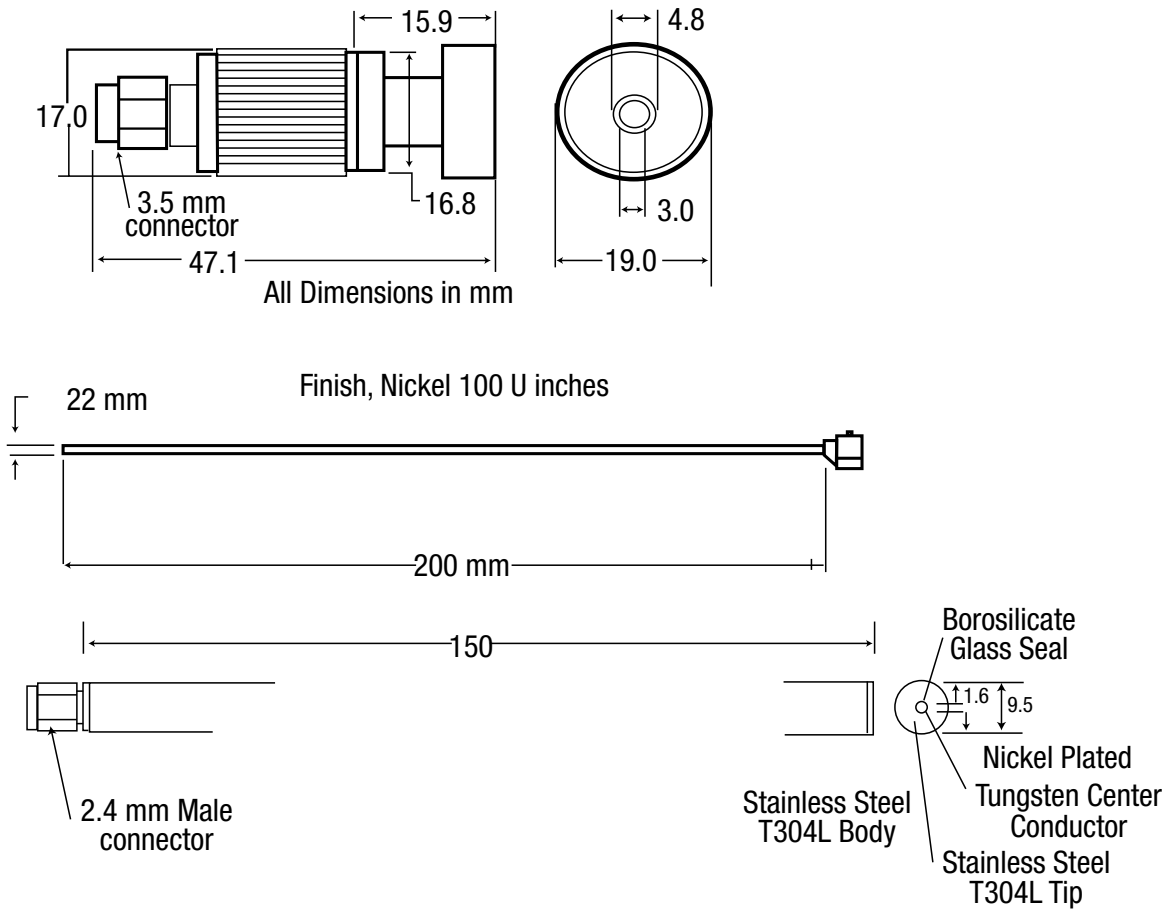

Figure 15.5. Coaxial probes

Transmission Line Method

A typical transmission line system consists of a vector network analyzer and a sample holder connected between the two network analyzer ports. The software calculates permittivity from calibrated full two-port S-parameter measurements. Keysight offers this software and several varieties of transmission line sample holders.

The material sample is assumed to fill the cross-section of the fixture with no air gaps, have smooth flat faces, and be uniform throughout. Coaxial airline fixtures are broadband, but the samples are more difficult to machine. Waveguide fixtures extend to the mm-wave frequencies and the samples are simpler to machine, but their frequency coverage is banded. Because the coaxial and waveguide transmission line size scales with frequency, the practical sample size determines the frequency limits. Waveguides at frequencies much lower than 5GHz start to get very large, and a large sample is needed. Below 1GHz for many materials, sample length also becomes an issue. At frequencies above 75GHz, both coaxial and waveguide dimensions get very small, and it becomes too difficult to machine the tiny samples.

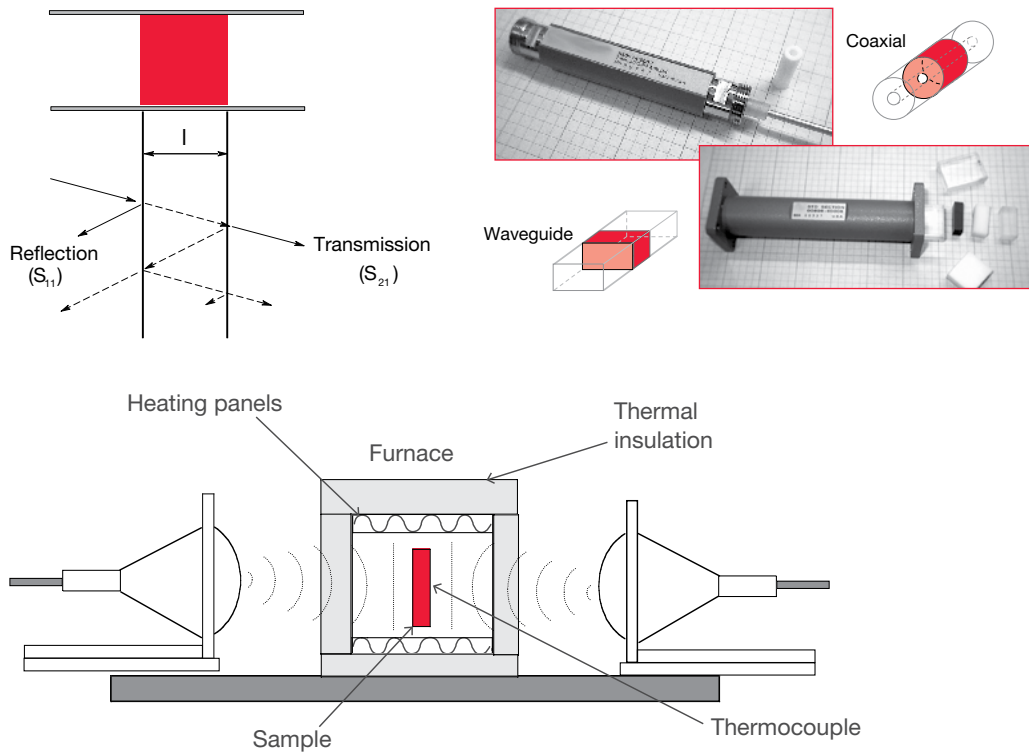

Figure 15.6. Transmission line method

Transmission line sample holders can be made from coaxial airlines or waveguide straight sections. Both are widely available in different frequencies from Keysight and other connector manufacturers. Samples must fit inside. This technique works best for hard solids that can be machined. It is possible, although more difficult to contain liquids and powders inside these. Coaxial sample holders offer broadband frequency coverage; however, it is more difficult to machine solid materials to the shape needed to fit inside. Waveguide straight sections offer banded frequency coverage, but it is much easier to machine solid materials to fit inside.

Table 15.1 shows the algorithms used in the N1500A material measurement suite from Keysight technologies. They will convert the measured S-parameters to permittivity or permeability. The first three require a two-port fixture. The last two require a one-port fixture which may be better for liquids or powders where a shorted waveguide section can be turned on end and filled. One-port fixtures may also be better for measurements at high temperatures where one end of the waveguide can be heated while cooling mechanisms keep the network analyzer cool.

A special variant of the transmission line method is “free space” and is best for high-temperature measurements since the sample is not enclosed in any kind of fixture, see Figure 15.6. The MUT is assumed to be large, flat, and uniform throughout. The free space antennas are connected to a vector network analyzer that measures the reflection and transmission from the MUT which are then converted to permittivity and permeability. There are many free space measurement methods available to choose

from. Free space techniques use antennas to focus microwave energy through a slab of material without the need for a test fixture. The same algorithms that are used for the transmission line technique can be applied to free space.

Algorithm	Measured	Optimum Length	Output
Nicolson-Ross (PN 8510-3)	$S_{11}, S_{21}, S_{12}, S_{22}$ or S_{11}, S_{21}	$\lambda_g/4$	ϵ_r and μ_r
Precision (NIST)	$S_{11}, S_{21}, S_{12}, S_{22}$	$n\lambda_g/4$	ϵ_r
Fast	S_{21}, S_{12} (S_{21})	$n\lambda_g/4$	ϵ_r
Short-circuited back	S_{11}	$\lambda_g/2$	ϵ_r
Arbitrary dielectric back	S_{11}	$\lambda_g/2$	ϵ_r

Table 15.1. Algorithms supported in N1500A material measurement suite

Resonant Cavity Method

The resonant cavity method is best suited for thin films, substrate materials, and other low-loss dielectric materials. The resonant cavity method uses a network analyzer to measure resonant frequency and Q of a resonant cavity fixture, first empty and then loaded with the sample under test. Permittivity can then be calculated from these measurements, knowing the volume of the sample and some other parameters about the resonant cavity. As it is a resonant method, only one frequency point is reported.

However, it is much more sensitive and has a better resolution than the other techniques. The typical resolution for this method is 10^{-4} whereas the broadband method is 10^{-2} . A least-squares circle fitting technique is used to calculate Q, which uses both magnitude and phase information and is more repeatable than other Q calculation methods. The software then calculates ϵ_r' , ϵ_r'' , and loss tangent and displays them in its easy-to-use interface.

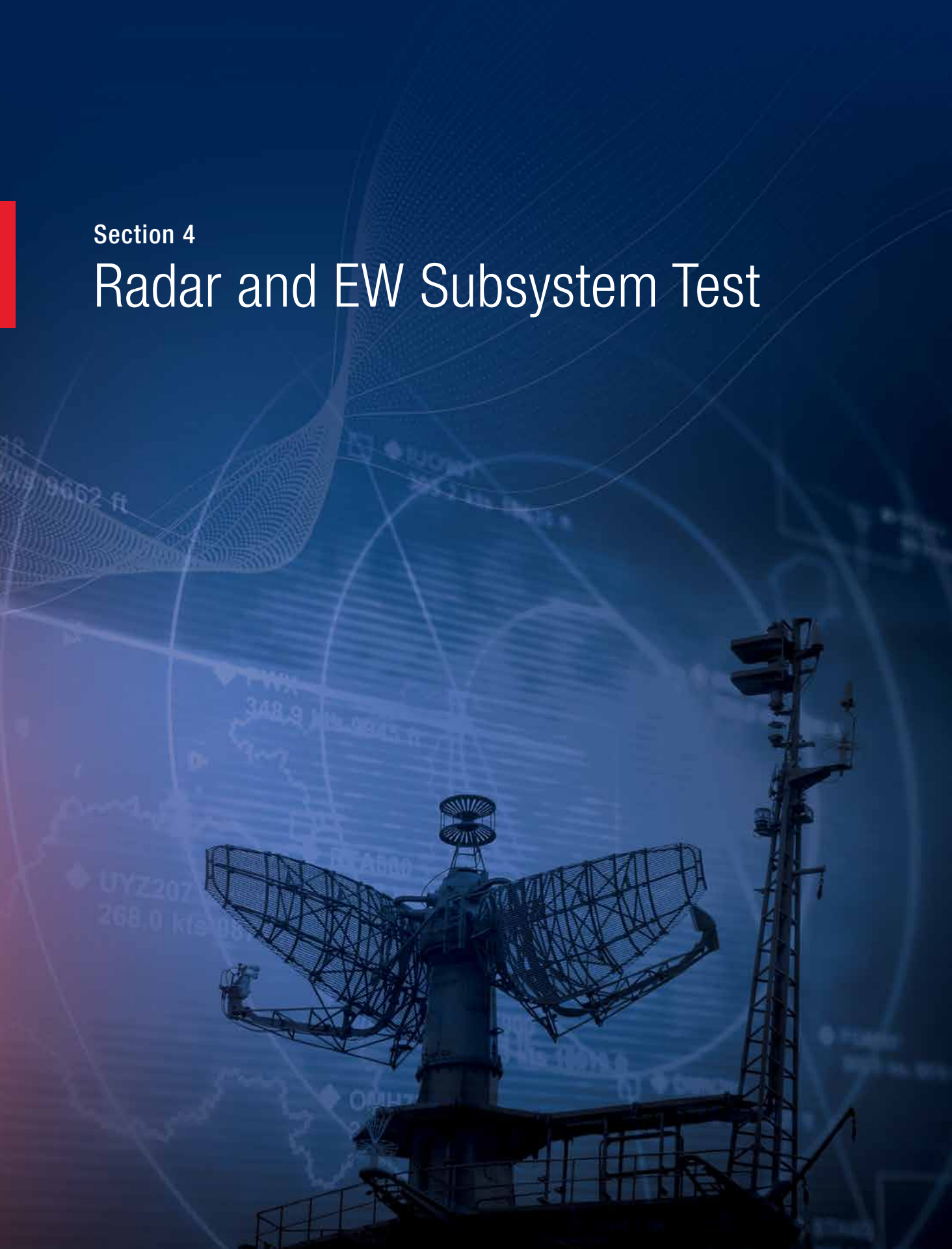

Figure 15.7. Resonant cavity method with network analyzer

Material characterization is a specialized and complex field of measurement. It has applications in numerous industries. Choice of measurement techniques depends on several factors and it is extremely important to choose the right method for your measurements to be able to achieve accurate measurements. Keysight provides comprehensive material characterization solutions and can act as a one-stop-shop of measurement gear, fixtures, and material measurement software.

Section 4

Radar and EW Subsystem Test



Introduction

For engineers and scientists, the names behind the earliest experiments in electromagnetism are part of our everyday conversations: Heinrich Hertz, James Clerk Maxwell, and Nikola Tesla. Fast forward from their work in the late 19th and early 20th centuries to the early 21st Century: the fundamental concept—metallic objects reflect radio waves—has evolved into a host of technologies that are pushed to the extremes in military applications: detecting, ranging, tracking, evading, jamming, and more.

As is the case in commercial electronics and communications, the evolution from purely analog designs to hybrid analog/digital designs continues to drive advances in radar system capability and performance. Frequencies keep reaching higher and signals are becoming increasingly agile. Signal formats and modulation schemes—pulsed and otherwise—continue to become more complex, and this demands wider bandwidth. Advanced digital signal processing (DSP) techniques are being used to disguise system operation and thereby avoid jamming. Architectures such as active electronically steered arrays (AESA) rely on advanced materials such as gallium nitride (GaN) to implement phased-array antennas that provide greater performance in beamforming and beam steering.

Within the operating environment, the range of complexities may include ground clutter, sea clutter, jamming, interference, wireless communication signals, and other forms of electromagnetic noise. It may also include multiple targets, many of which utilize materials and technologies that present a reduced radar cross-section.

This section moves ahead from component level to subsystem level characterization. Starting with the basics of radar and EW transmitter and receiver, it covers new age requirements, technologies and instruments to measure those. The section also highlights the methodology to test Transmit-Receive (TR) modules efficiently and concludes with understanding different techniques of antenna testing.



Chapter 16 Signal Source Essentials- Parameters, Technologies, and Methods

The essence of radar is the ability to gather information about a target — location, speed, direction, shape, identity, or simply presence. This is done by processing reflected radio frequency (RF) or microwave signals in the case of primary radars, or from a transmitted response in the case of secondary radars.

In most implementations, a pulsed-RF or pulsed-microwave signal is generated by the radar system, beamed toward the target in question, and collected by the same antenna that transmitted the signal. This basic process is described by the radar range equation. The signal power at the radar receiver is directly proportional to the transmitted power, the antenna gain (or aperture size), and the radar cross-section (RCS) (i.e., the degree to which a target reflects the radar signal). Perhaps more significantly, it is indirectly proportional to the fourth power of the distance to the target. Given the large attenuation that occurs while the signal is traveling to and from the target, having high power is very desirable; however, it is also difficult due to practical problems such as heat, voltage breakdown, dynamic power requirements, system size, and, of course, cost.

Radar Signal Parameters

Every radar transmission starts with a known carrier signal and today these typically operate at microwave or millimeter-wave frequencies. The carrier may be coded, in part because changes in the return signal provide a more accurate measurement of the distance to the target. In most cases, pulse modulation is also applied because, controlling pulse duration, repetition rate and power, enhances the resolution and maximum range of the radar system. Radar signals can be defined in the Time Domain, Frequency Domain, and in terms of Pulse Descriptor Words (PDW) that are defined by amplitude, frequency, and timing information. The advantage of PDWs is that they are an efficient way to store and digitally stream radar signals.

Optimizing Pulse Parameters

The characteristics of a pulsed radar signal largely determine the performance and capability of the system. Pulse parameters such as power, repetition rate, width, and modulation are traded off to obtain the optimum combination for a given application (Figure 16.1). Pulse power directly affects the maximum range of detection. Droop across the pulse top indicates instability in the output power.

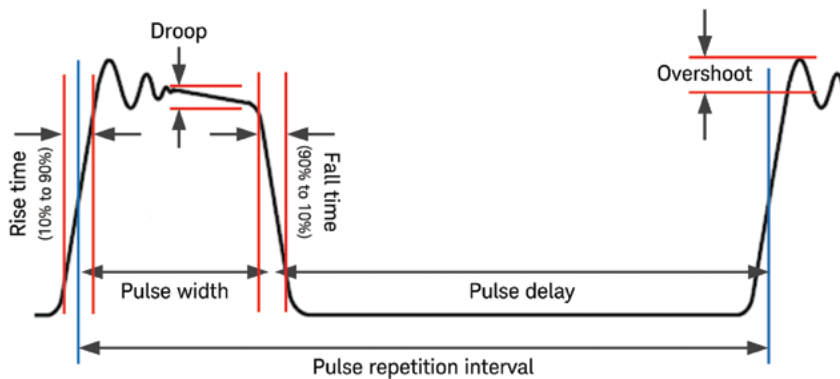

Figure 16.1. The essential characteristics of real-world pulses affect the performance of the radar system.

The time between pulses—the pulse-repetition interval (PRI)—determines the maximum unambiguous range to the target; pulse repetition frequency (PRF) is the inverse of PRI. The duration of the pulse—the pulse width—determines the spatial resolution of the radar: pulses must be shorter than the time it takes for the signal to travel between the target details; otherwise, the pulses overlap in the receiver.

Together, pulse width and pulse shape determine the spectrum of the radar signal. Decreasing the pulse width increases signal bandwidth; however, wider system bandwidth results in higher receiver noise for a given amount of power, and this reduces sensitivity. Also, the pulse spectrum may exceed regulated frequency allotments if the pulse is too short.

The shape can be the familiar trapezoidal pulse with rapid but controlled rise and fall times; it may also be an alternative shape such as Gaussian and/or raised-cosine. Because the pulse shape can determine the signal bandwidth and also affect the detection and identification of targets, it is chosen to suit the application requirements.

Short pulses with a low repetition rate maximize resolution and unambiguous range, and high pulse power maximizes the radar's range in distance. There are, however, practical limitations in generating short, high-power pulses. For example, higher peak power will shorten the life of tubes used in high-power amplifier designs. This conundrum would be a barrier to increasing radar performance if radar technology stopped here. However, complex waveforms and pulse-compression techniques can be used to greatly mitigate the power limitation on pulse width.

Adding Pulse Compression

Compression techniques allow relatively long RF pulses to be used without sacrificing range or resolution. The key to pulse compression is energy: using a longer pulse reduces the peak power of the transmitted pulse but maintains the same average pulse energy. The received pulse is compressed using a match-correlation filter, producing a shorter pulse of greater peak power and narrower width.

From this, a pulse-compression radar realizes many of the benefits of a short pulse: improved resolution and accuracy; reduced clutter; better target classification; and greater tolerance to some electronic warfare (EW) and jamming techniques. One area that does not improve is minimum range performance: the long transmitter pulse may obscure targets that are too close to the radar.

The ability to compress the pulse with a matched filter is achieved by modulating the RF pulse in ways that facilitate the compression process. The matching filter function can be achieved digitally using the cross-correlation function to compare the received and transmitted pulses. The sampled receive signal is repeatedly time-shifted, fast Fourier transformed and multiplied by the conjugate of the Fourier transform of the sampled transmit signal (or a replica).

The output of the cross-correlation function is proportional to the time-shifted match of the two signals. A spike in the cross-correlation function or matching-filter output occurs when the two signals are aligned. This spike is the radar return signal, and it may be 1000 times shorter in duration than the transmitted pulse.

Even if two or more of the transmitted pulses overlap in the receiver, the sharp rise in output occurs only when each pulse is aligned with the transmit pulse. This restores the separation between the received pulses and, with it, the range resolution. To reduce the time-domain sidelobes created during the cross-correlation process, the received waveform can be processed with a windowing function of Hamming shape or similar.

Ideally, the correlation between the received and transmitted signals would be high only when the transmitted and received signals are exactly aligned. Many modulation techniques can be used to achieve this goal: linear FM sweep, binary phase coding (e.g., Barker codes), or polyphase codes (e.g., Costas codes).

Accounting for Doppler Effects

Most targets of interest are moving. This causes the frequency of the returned signal to be shifted higher if the target is moving toward the radar and lower if the target is moving away. Unfortunately, this Doppler frequency shift can reduce the sensitivity of location detection.

As mentioned above, the output of the cross-correlation filter is proportional to the match between the received and transmitted signals. If the received signal is slightly lower or slightly higher in frequency, then the filter output is somewhat lower.

For a simple pulse, the filter response follows the familiar $\sin(x)/x$ shape as a function of Doppler frequency. In extreme cases, the frequency of the received signal may shift far enough to correlate with a sidelobe of the transmit signal.

Note that short pulses have a relatively wide initial lobe in the $\sin(x)/x$ response and so tend to be “Doppler tolerant” compared to longer pulses. In pulse compression schemes such as Barker coding, the matching-filter output drops off much faster than the $\sin(x)/x$ of the simple pulse, making them “Doppler intolerant.”

Doppler shifts in linear FM pulses can create an error in the location information because the highest cross-correlation occurs where the swept frequencies in the received pulse are best aligned with the swept frequencies in the transmit pulse. This offset is directly proportional to the Doppler shift.

Bringing it all Together

Graphs called ambiguity diagrams illustrate the performance of different pulse-compression schemes as a function of pulse width and Doppler frequency shift (Figure 16.2). Even though Doppler shift can reduce detector sensitivity and cause errors in time alignment, it also provides important information about the target.

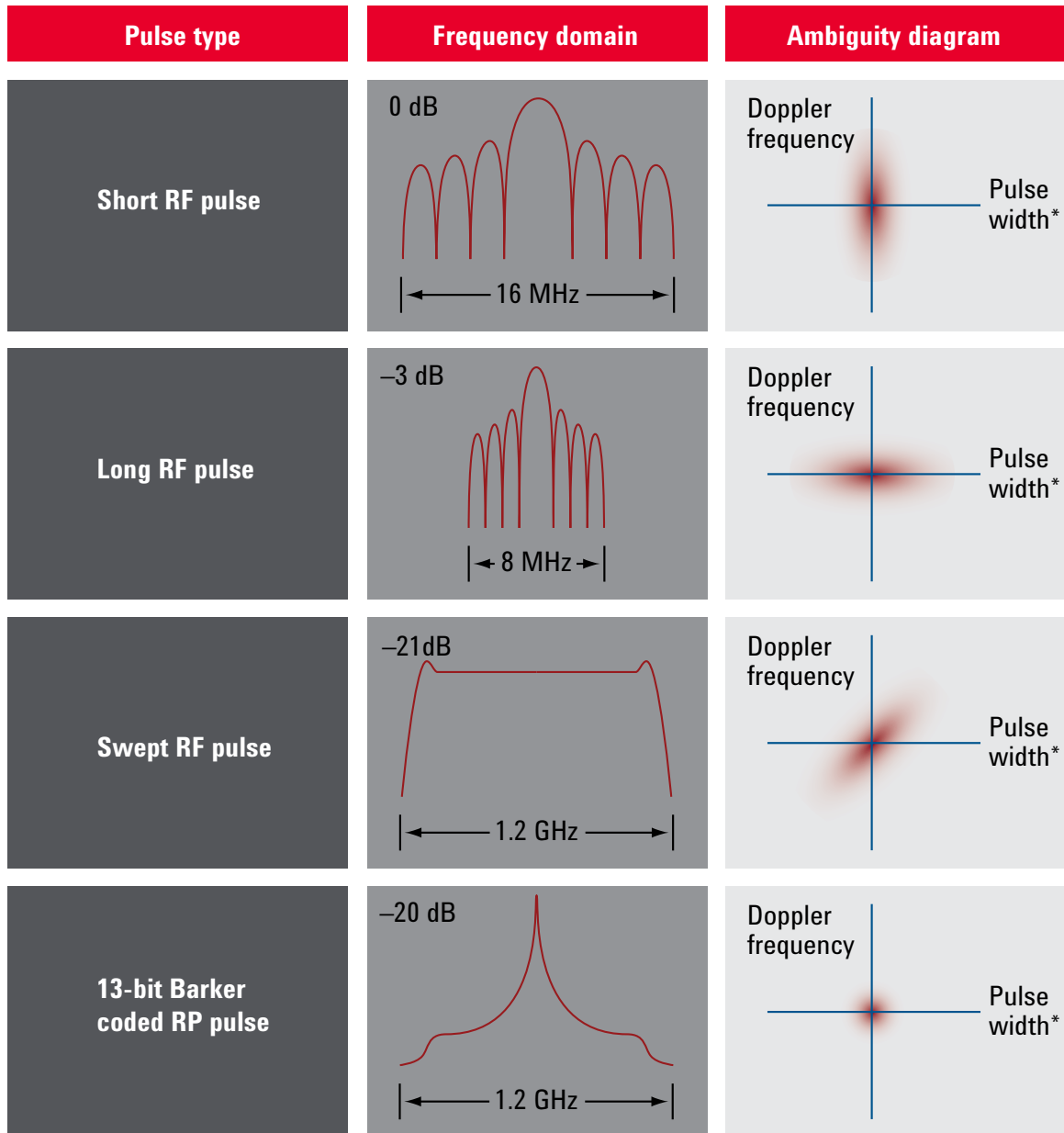

Figure 16.2. The ambiguity diagrams illustrate location accuracy versus Doppler accuracy. This figure shows relative ambiguity diagrams for different types of radar pulses.

*Note: in the ambiguity diagram, “pulse width” refers to the width at the output of the radar detector.

Signal Generator Essentials

Engineers use signal generators to test components, receivers, and systems for a variety of applications throughout the product development cycle. The output signal can be as simple as a continuous wave (CW) or complex, like a digitally modulated signal. Figures 16.3 and 16.4 show common signal generator use cases for component and receiver tests.

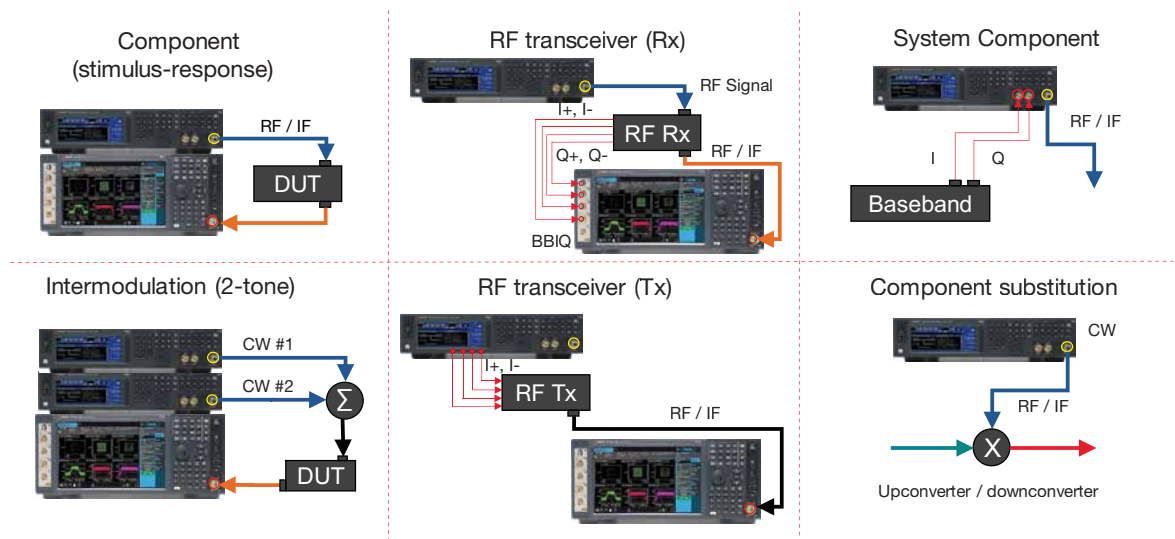

Figure 16.3. Signal generator use cases for component characteristic tests or a system component

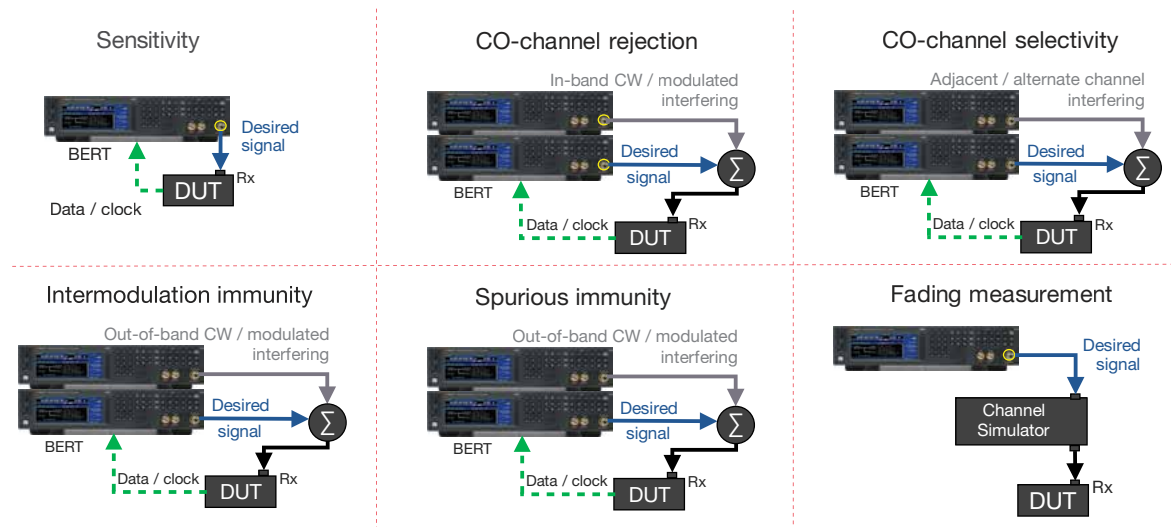

Figure 16.4. Signal generator use case for receiver sensitivity tests

Signal generators can be classified based on their form factor and capabilities.

Form Factor: Benchtop or Modular?

The most common signal generator form factor is the benchtop. We typically see these boxed instruments on benches and in racks. Benchtop signal generators are well-suited for R&D, where engineers use the front panel controls to analyze and troubleshoot devices.

The PXIe modular form factor signal generators are compact instruments housed in a PXIe chassis and controlled using a PC. Several PXIe signal generators can be placed in a single chassis, making them ideal for applications that require multi-channel measurement capabilities, fast measurement speed, and a small footprint. A PXIe signal generator often uses the same software applications as a benchtop signal generator, providing measurement consistency and compatibility from product development to manufacturing and support.



Figure 16.5. Benchtop and PXI modular signal generator

Capabilities: Analog, Vector, and Agile Signal Generators

Analog signal generators supply sinusoidal continuous wave (CW) signals with optional capability to add AM, FM, Φ M, and pulse modulation. The maximum frequency range for analog signal generators spans from RF to microwave. Most generators feature step/list sweep modes for passive device characterization or calibration.

Vector signal generators (VSG), a more capable class of signal generators, enable complex digital modulation schemes. VSGs have a built-in quadrature (also called IQ) modulator to generate complex modulation formats such as quadrature phase-shift keying (QPSK) and 1024 quadrature amplitude modulation (QAM). When combined with an IQ baseband generator, virtually any signal can be emulated and transmitted within the information bandwidth supported by the system.

Optimized for speed, agile signal generators can quickly change frequency, amplitude, and phase of the signal. They also have the unique capability to be phase coherent at all frequencies, at all times. This attribute, along with extensive pulse modulation and wideband chirp capabilities, make them ideal for electronic warfare and radar applications.

Overview of Key Specifications

To select the right signal generator for your project, you'll need to understand its performance specifications. Specifications tell you about the capability of your signal generator. Let's explore major specifications: frequency, amplitude, and spectral purity performance.

Frequency specifications

The frequency specification defines the range, resolution, accuracy, and switching speed of your signal generator.

- Range — the maximum and minimum output frequencies your signal generator can output.
- Resolution — the smallest frequency change.
- Accuracy — how close the source's output frequency is to the set frequency.
- Switching — how fast the output settles down to the desired frequency.

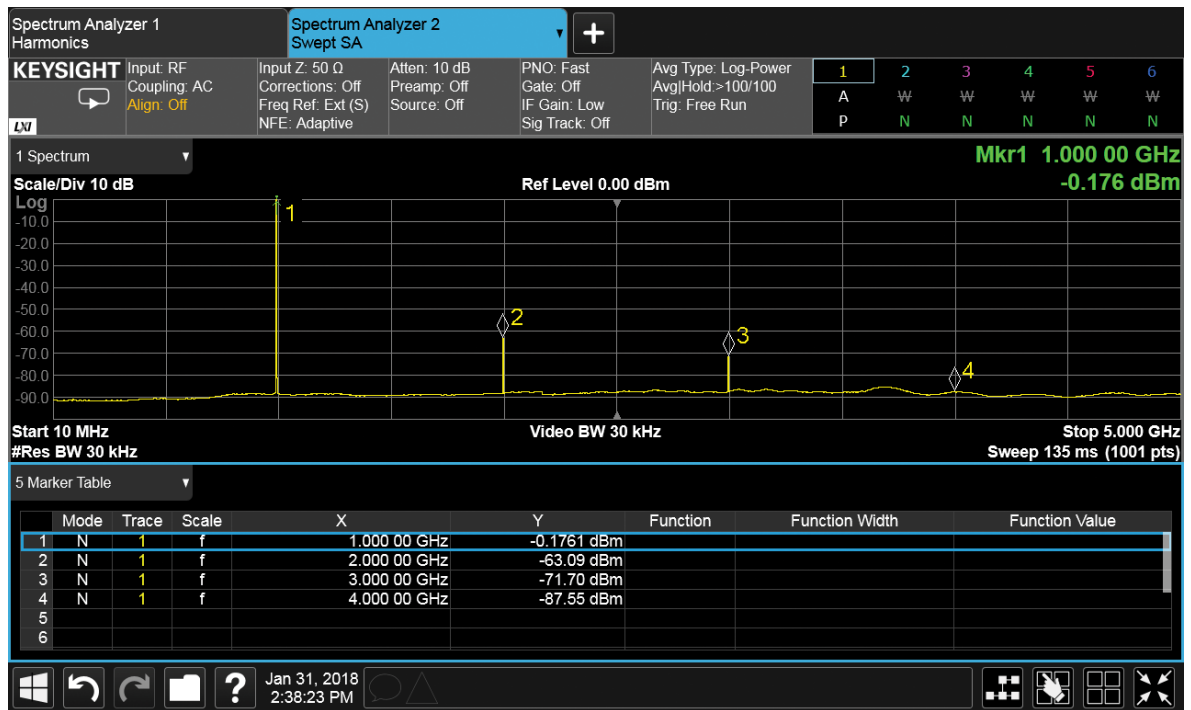

Figure 16.6. Spectrum analysis with frequency and amplitude readouts

Amplitude specifications

Amplitude specifications include range, resolution, and switching speed.

- Range — the difference between the maximum and minimum output power capability of the signal generator. The signal generator's output attenuator design determines its range. The output attenuator allows the signal generator to produce extremely small signals used to test a receiver's sensitivity.
- Resolution — the smallest possible power increment.
- Switching speed — how fast the source can change from one power level to the next.

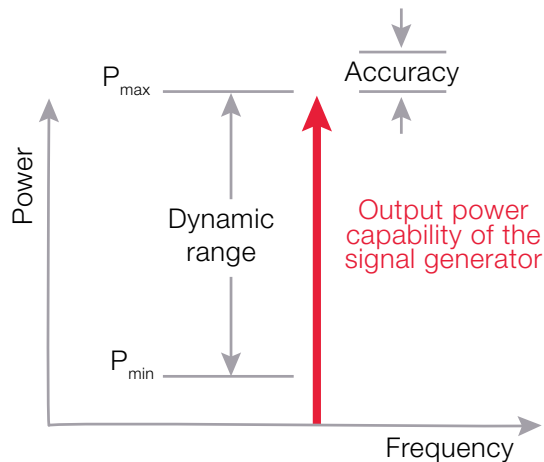

Figure 16.7. Power output range and accuracy

Spectral purity

Spectral purity is the inherent stability of a signal. A perfect signal generator will generate a sinusoidal wave at a single frequency without the presence of noise. However, signal generators consist of non-ideal components which introduce noise and distortion. The specifications associated with spectral purity are often the most difficult to understand. These specifications include phase noise, harmonics, and spurs as shown in Figure 16.8.

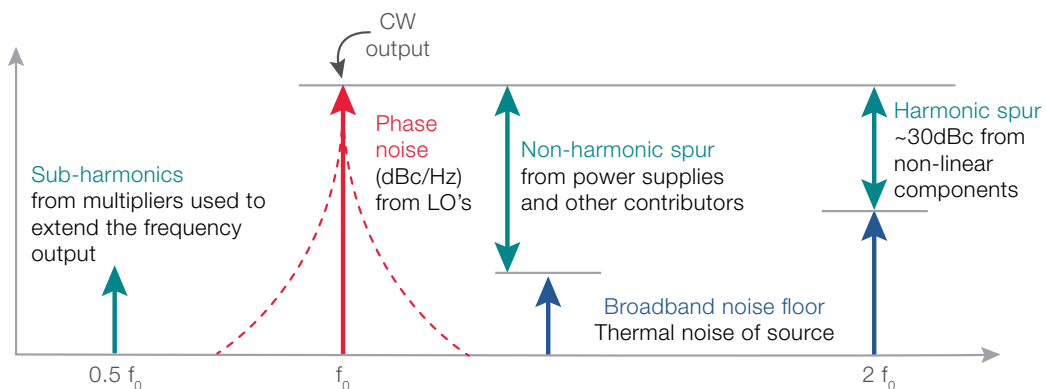

Figure 16.8. Various non-ideal spectral components

- Phase noise — a frequency-domain view of the noise spectrum around the oscillator signal. It describes the frequency stability of an oscillator.
- Harmonics — integer multiples of the sinusoidal fundamental frequency output. These harmonics are caused by the non-linear characteristics of components used in the signal generator.
- Spurs — non-random or deterministic signals created from mixing and dividing signals to get the carrier frequency. These signals may be harmonically or non harmonically related to the carrier.

Ultra-Wideband Arbitrary Waveform Generators (AWGs)

Arbitrary waveform generators can vary in regards to sample rate and resolution, and those two parameters are often inversely related (Figure 16.9). AWGs with higher sample rates will have lower resolutions than those with lower sample rates and vice-versa. AWGs can be used to simulate high-density radar signals and communications signals within their bandwidths.

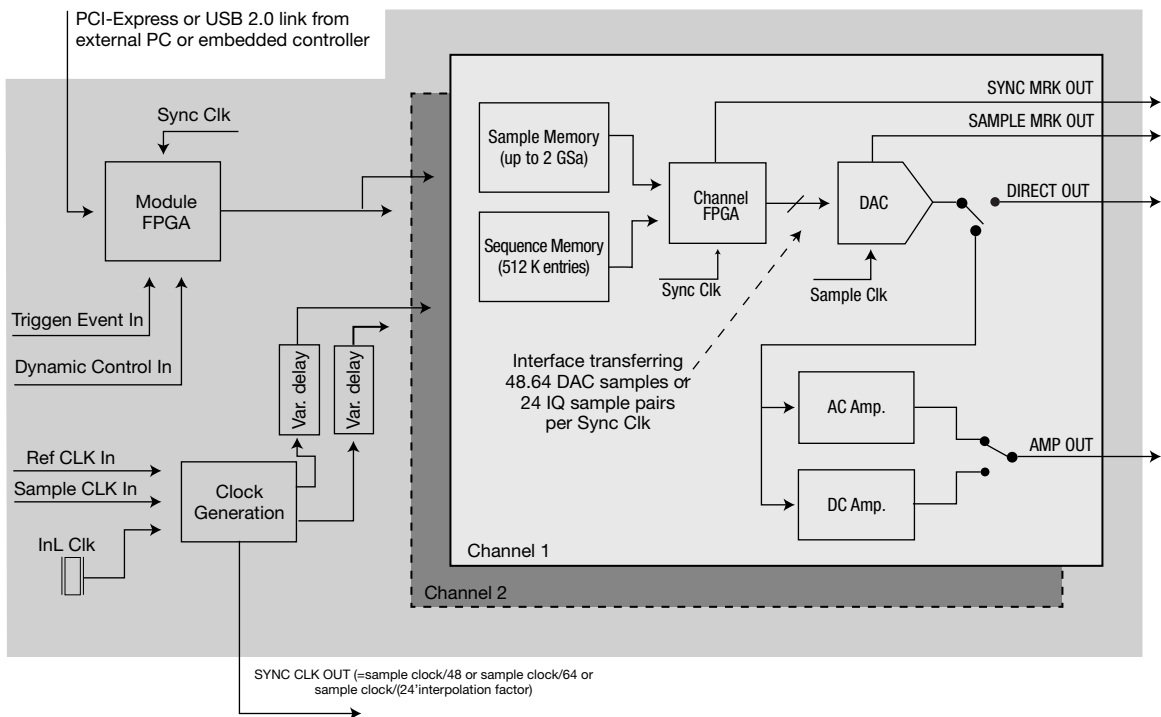
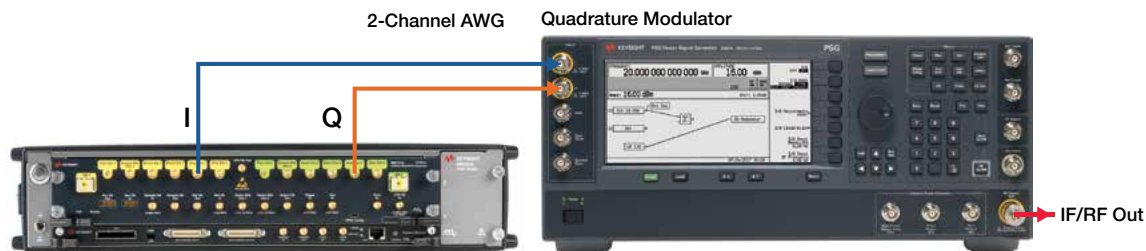

Figure 16.9. Modern Arbitrary Waveform Generators are comprised of much more than DACs. Such new capabilities involve memory sequencing, clock sharing for synchronization, and different output paths to optimize signals depending on the application. Shown here is the block diagram for the high-resolution M8190A Arbitrary Waveform Generator.

Ultra-wideband AWGs have extremely wide bandwidth, which allows for the generation of single and multiple emitters across wide frequency spans. High-resolution AWGs can output signals with a high dynamic range within narrower bandwidths. Key capabilities include support for simultaneous pulses (pulse-on-pulse) and the ability to modify I/Q data to allow for environmental effects. Multiple channels can also be synchronized rather easily for tests requiring multiple coherent channels. In contrast to other source types, ultra-wideband AWGs tend to have lower resolution and dynamic range. They also require a large amount of storage due to their extremely high sample rates. High-resolution AWGs have lower bandwidths and can be upconverted using the appropriate architecture.

a) Baseband Generation



b) Direct RF Generation in the First Nyquist Band



Figure 16.10. AWGs can generate radar (and any RF) signals following to different basic schemes

Electronic Warfare Signal Generation Technologies and Methods

Productive and efficient engineering of electronic warfare (EW) systems requires the generation of test signals that accurately and repeatedly represent the EW environment. Simulation of multi-emitter environments is vital to ensure realistic testing.

Simulation for these multi-emitter environments traditionally encompasses large, complex, and custom systems during the system qualification and verification stage. These systems are usually not widely available to EW design engineers as R&D test equipment. EW designers working on optimization and pre-qualification are at a disadvantage in comparison to wireless engineers performing similar tasks. EW engineers often discover the nature and magnitude of performance problems later in the design phase — leading to delays, design rework, and solutions that are not optimal.

Realism and fidelity in multi-emitter environments

Validation and verification of EW systems are heavily dependent on testing with realistic signal environments. Adding high-fidelity emitters for greater signal density creates a realistic EW test environment. In addition, emitter fidelity and density, platform motion, emitter scan patterns, receiver antenna models, the direction of arrival, and multipath and atmospheric models enhance the ability to test EW systems under realistic conditions. The designs for modern EW systems can identify emitters using precise direction finding and pulse parameterization in dense environments of millions of pulses per second.

The cost of the test is as important as test realism, as the relationship between cost and test fidelity is exponential. As test equipment becomes more cost-effective and capable, more EW testing can be performed on the ground — in a lab or chamber — rather than in flight. Even though flight testing can add test capability, it does so at a high cost. It is typically done later in the program lifecycle, adding risk and further expense to the program through missed deadlines if the system under test (SUT) fails. It is far better to test early in a lab environment with as much realism as possible, where tests are easily repeated to identify iteratively and to resolve issues.

Challenges of simulating multi-emitter environments

The modern spectral environment contains thousands of emitters — radios, wireless devices, and tens to hundreds of radar threats — producing millions of radar pulses per second amidst background signals and noise. Figure 16.11 shows a general overview of the threat frequency spectrum.

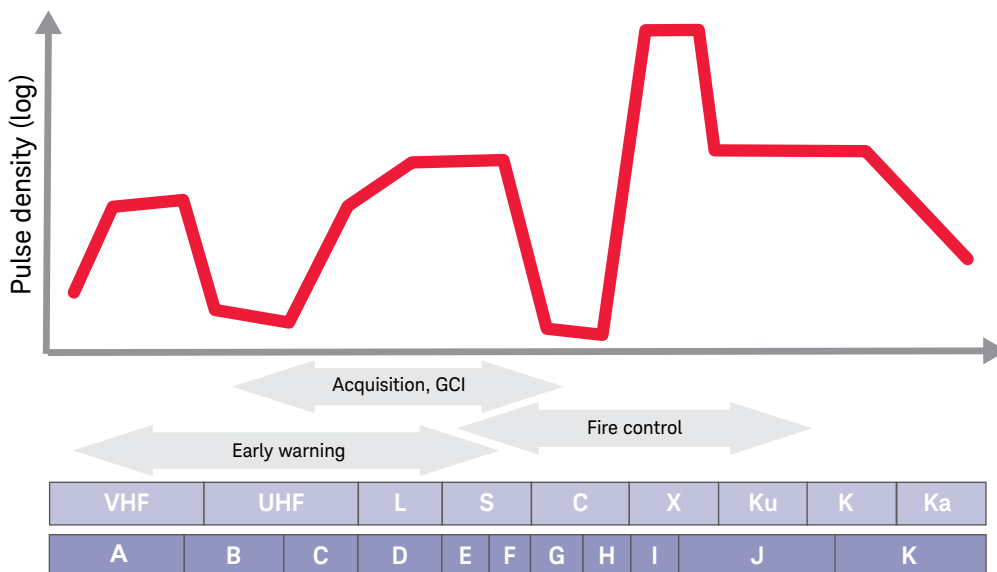

Figure 16.11. A general representation of the threat density vs. frequency band in a typical operational environment. The full RF/microwave environment would be a combination of the threat and commercial wireless environments.

Simulating this environment is a significant challenge — especially in the design phase when design flexibility and productivity are at their greatest. The situation is quite different from the typical wireless design task, where a single signal generator can produce the required signal, augmented by a second signal generator to add interference or noise.

In EW design, the multiplicity and density of the environment — and often the bandwidth — make it impractical to use a single source or a small number of sources to simulate a single emitter or a small number of emitters. Cost, space, and complexity considerations rule out these approaches.

The only practical solution is to simulate many emitters with a single source, and to employ multiple sources — each typically simulating many emitters — when required to produce the needed signal density or to simulate specific phenomena such as angle-of-arrival (AoA).

The ability to simulate multiple emitters at multiple frequencies depends on the following: pulse repetition frequency; duty cycle; number of emitters; and the capability of the source to switch between frequency, amplitude, and modulation quickly.

A source's agility is a factor in its ability to simulate multiple emitters. Source frequency, phase, and amplitude settling time (whichever is greater) is the transition time between playing one pulse descriptor word (PDW) and the next.

Improvements simplify integration and reduce cost

Simulating more threats to create higher pulse density requires more parallel simulation channels — even if the simulation channel can switch frequency, phase, and amplitude quickly. This is because pulses begin to collide in the time domain as the number of emitters, their PRFs, and their duty cycles grow larger¹. Pulse that overlap in the time domain must be played out of parallel generators or selectively dropped based on a PDW priority scheme. Unfortunately, the increased realism of a higher-density environment comes at a substantially higher system cost, as shown in Figure 16.12.

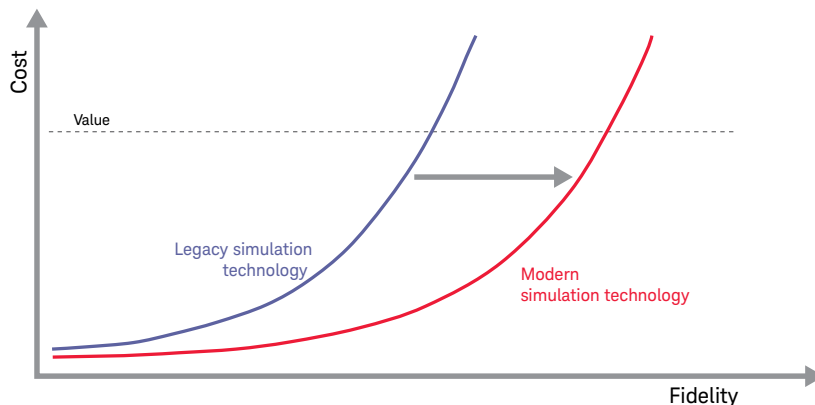

Figure 16.12. Simulation fidelity and cost increase exponentially. System integrators and evaluators must determine the level of cost versus fidelity to ensure system performance. New simulation technologies enable more simulation realism and fidelity at a lower cost.

In the past, simulations have generally been created with a separate component for each emulation function, such as signal generation, modulation/pulsing, attenuation or amplification, and phase shift. The same PDW would be sent to each functional component to provide output on a pulse-to-pulse basis. For instance, a synthesizer would generate the output frequency, while a separate modulator would create pulsed modulation or AM/FM/PM modulation. Amplifiers and attenuators would adjust the signal to the desired output power level. Figure 16.13 is an example of the system's topology.

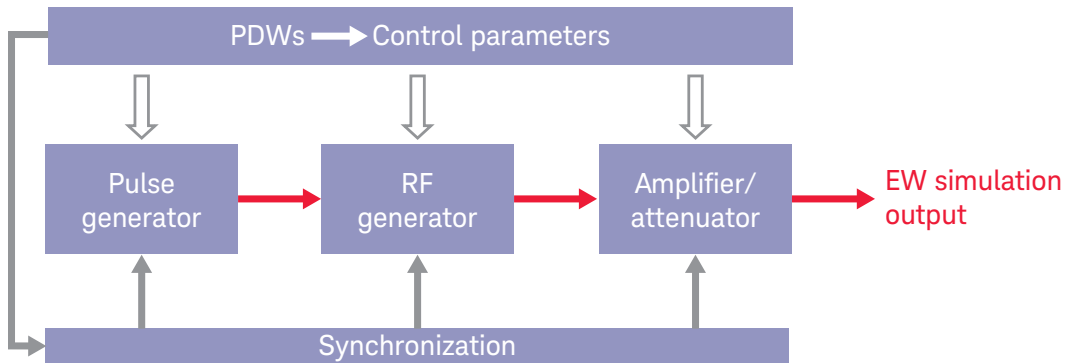

Figure 16.13. In the traditional approach, PDW control parameters are sent in parallel to multiple functional elements, on a pulse-to-pulse basis, to generate and modify the desired signal. This approach results in a complex system, demanding precise synchronization.

Because multiple functional components are required to produce each output channel, time synchronization is a significant configuration and operational challenge. A wide variety of settling times and latencies must be fully characterized to optimize pulse density by minimizing lockout periods.

This approach can be scaled directly to create multiple coordinated channels, as shown in Figure 16.14. However, systems configured in this way require a large footprint — occupying more rack space — and cost escalates quickly.

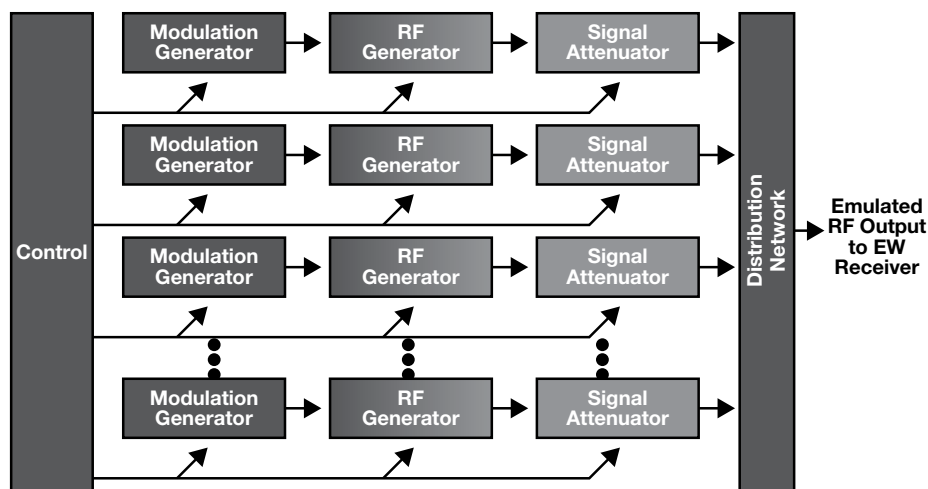

Figure 16.14. A signal generation approach using separate functional elements can be scaled up to increase pulse density and generate a more realistic environment. The cost and space requirements scale up rapidly as well².

The controller in Figure 16.14 would route PDWs to channels based on emitter parameters, such as frequency, amplitude, and pulse repetition frequency, and the availability of each channel to implement the PDW. Because a channel cannot execute the parameters of two different PDWs at the same time, one could be shunted to a backup channel or dropped according to its priority.

EW receivers must be able to handle millions of pulses per second, where most of the pulse density occurs at the X-band. EW receivers must be able to handle pulses arriving at the same time at different frequencies from different angles. Creating pulses that are coincident with one another in the time domain should be a goal of simulation to increase simulation realism.

Though Figure 16.14 describes a very capable system, the system elements are not highly integrated. Recent developments in analog and digital signal generation technologies are enabling a higher degree of integration and solutions which are more cost- and space- efficient.

There are several methods of controlling simulations, depending on test objectives. Figure 16.14 shows systems with a traditional, distributed architecture. The synchronization of an agile local oscillator (LO) with functions such as pulse modulation, frequency/phase modulation, and amplitude control is a considerable challenge. In an integrated EW test solution such as the UXG, this synchronization is automatic, provided by the test equipment itself. By simplifying hardware and system complexity, this integrated approach promises to improve both performance and reliability.

Control of hardware-in-the-loop testing

Depending on the integration of simulation elements and the simulation length, scenarios can be played from list memory or streamed over a digital interface such as LAN or low-voltage differential signaling (LVDS). List mode plays PDWs from list memory for shorter scenario lengths with some ability to trigger between lists for an adaptive (closed-loop) simulation in response to the SUT.

For example, there is often a need to switch between one simulated threat mode to another in response to identification and jamming by the SUT. For long scenario lengths with fast control over scenario changes, PDWs can be streamed over the LAN to the signal generation system operating in an agile controller mode. In this case, simulation software generates batches of PDWs according to simulation kinematic granularity and streams them ahead of their desired playtime.

The goals are to stress the SUT with increasing pulse density, depending on the number of simulation channels available and the parameters of the threats to be simulated. As pulse density increases, PDWs can be dropped according to a priority scheme as they increasingly collide in the time domain, and there are insufficient signal generation channels to play them.

Creating AoA

In addition to creating emitters with the desired fidelity and density, it is also important to match the geometry and kinematics of EW scenarios. This is because the AoA of a radar threat to the EW system changes slowly compared to other parameters, such as center frequency and pulse repetition frequency.

EW systems measure AoA and estimate distance using amplitude comparison, differential Doppler, interferometry (phase difference), and time difference of arrival (TDoA). Precise AoA measurements enable precise localization of radar threats. New stand-off jamming systems use active electronically scanned arrays capable of precise beamforming to minimize loss of jamming power due to beam spreading toward a threat. EW receivers with better AoA capability reduce the need for pulse deinterleaving and sorting. Consequently, AoA is an increasingly important test requirement.

Techniques for creating AoA

In the past, AoA was created with a combination of signal sources and analog phase shifters, attenuators, and gain blocks in the cable path to the SUT. Analog elements in the cable path took up space, had limited resolution, and were expensive.

As an alternative, and depending on their architecture, sources can be linked together to create phase-coherent output, allowing for exceptional control over creating phase fronts to the SUT. Similarly, amplitude control at the source can be used to create appropriate amplitude differences at SUT receive channels.

The ability to control AoA to meet modern test requirements depends on the architecture of the source. At a minimum, it should be possible to lock the LOs of multiple sources together so that they all share the same phase. Often, calibration is required to align the phase and timing between sources.

Creating small, accurate, and repeatable differences in phase or frequency between channels is the next challenge. Sources based on a direct digital synthesis (DDS) architecture allow AoA to be controlled digitally in a numerically controlled oscillator. Phase alignment in a DDS source is then a matter of sharing reference clocks. Calibrations to provide accuracy and repeatability can be uploaded to a table to be applied in real-time.

Overview of source technologies for EW test

The characteristics and tradeoffs of EW signal generation systems are primarily determined by the core synthesizer and oscillator technologies used. This section summarizes the key technologies currently available:

- Direct analog synthesis (DAS)
- A phase-locked loop or indirect analog synthesis (PLL, frequently fractional-N) – Direct digital synthesis

General source requirements

Signal sources used to test EW systems must be broadband. Traditionally, a frequency range of 0.5 to 18 GHz was required. Frequency requirements have expanded dramatically in recent years, now beginning near DC and extending as high as 40 GHz. They allow systems to simulate an early warning, fire control, and missile-seeking radars from a single output channel.

In addition to wide frequency coverage, sources for the EW test must have fast frequency, phase, and amplitude switching speeds to simulate different radars operating in different modes in various frequency bands.

PLLs and fractional-N synthesis

Indirect synthesis

Most general-purpose sources today are PLL-based, where a broadband oscillator such as a voltage-controlled or YIG-tuned oscillator is locked to a stable reference in a phase-locked loop (PLL). The PLL improves signal quality by reducing phase noise and spurious signals in the output. PLL-based sources have been configured with a combination of sum and step loops or a single-loop with a fine fractional division capability. These fractional-N PLLs offer excellent signal quality and fine frequency resolution in a cost-effective single-loop configuration, making them an excellent choice for general-purpose signal sources.

The required control loop filtering in PLLs results in a significant settling or loop response time. This looping limits the ability of the synthesizer to switch frequency quickly. Due to their comparatively high transition time, these sources are limited in their ability to simulate multiple radar threats out of a single channel, even if they have the necessary broadband frequency coverage and frequency resolution. They also lack phase-repeatable switching capability.

Direct analog synthesis

A direct analog synthesizer typically contains several stable frequency references multiplied or divided from the same crystal oscillator reference. These frequency references (and their harmonics) can be switched in and out of the signal path and multiplied, divided, added, and subtracted to provide fine frequency resolution quickly. The frequencies of these references are chosen to reduce the number of multiplication stages required, such that phase noise increases only moderately as the frequency is increased. The division to lower frequencies reduces the phase noise.

Since the switches and arithmetic operators used in the DAS approach operate very quickly and do not need loop filtering, these synthesizers have very high-frequency agility. They are a typical architecture for traditional EW test solutions.

However, DAS technology has several drawbacks. First, numerous stages are required to achieve the desired frequency resolution. Switching parallel and series multiplication, division, and mixing stages require more hardware than PLLs and reduces reliability. Second, circuit noise from each stage is cascaded, and phase noise is multiplied through the stages. Finally, each stage adds components that increase size, weight, and cost.

On the positive side for EW applications, DAS has the potential for limited phase-repeatable frequency switching. All frequencies are usually derived from the same reference, but divider ambiguities generally preclude full phase-coherent switching.

DDS now suitable for EW applications

The DDS approach, based on DAC circuits, is a natural fit for the needs of EW signal simulation. However, until recently, DACs were not available with the required combination of fast sample rates and high purity.

Fast sample rates are needed to produce outputs with very wide bandwidth so that a minimum of multiplying stages can be used to create the desired output frequencies. The use of either many multiplying stages or a DAC of insufficient purity would limit the effective spurious-free dynamic range (SFDR) of the EW synthesizer.

In concept, a DDS is one of the simplest types of signal generators. In a frequency-tunable DDS, data from a numerically controlled oscillator is converted to analog form by a DAC and low-pass filtered to remove image frequencies and harmonics. A block diagram of the key elements of a DDS is shown in Figure 16.15.

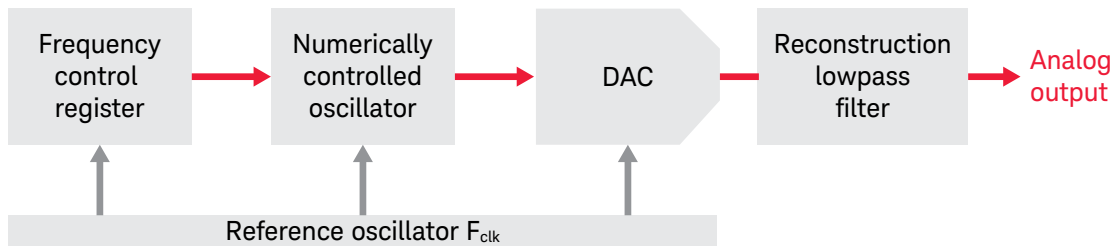

Figure 16.15. Principal functional blocks of a direct digital synthesizer

Advantages of DDS

The Keysight UXG agile signal generator uses DDS technology made possible by a proprietary DAC to generate multi-emitter simulations. DDS has several advantages over other synthesis technologies for EW applications: Digital control of extremely fine frequency and phase tuning increments within a single clock cycle.

In the UXG agile signal generator, the frequency resolution is one millihertz and phase resolution is sub-degree. Fractional-N techniques can provide microhertz resolution, but frequency changes are much slower due to PLL filtering. DAS techniques provide rapid frequency switching, but at a cost in frequency resolution.

DAS techniques offer hop speed and frequency/phase repeatability only under limited conditions. Modulation is created in the digital domain, providing numerical precision and repeatability.

There are other advantages to using DDS that are of interest to the EW engineer. Many DDSs employ a digital modulator for amplitude, frequency, and phase modulation for the creation of digitally modulated signals in the numerically controlled oscillator. Linear frequency modulated (LFM) chirps and Barker codes can also be directly synthesized using the numerically controlled oscillator. Chirp bandwidth depends on the bandwidth of the bandpass filters after each multiplication stage and whether the signal is crossing a band.

Advanced Threat Simulation

The DDS architecture provides many advantages for EW threat simulation. As radar threats grow more advanced and sophisticated, threat simulation systems must produce high-fidelity reproductions of these signals. These reproductions include shaped pulses with varying rise and fall times, non-linear chirps, or custom modulation. Implementing these effects with traditional analog building blocks, such as pulse and I/Q modulators, can prove challenging. Fortunately, modern digital I/Q baseband systems can accurately generate these complex waveforms while minimizing distortion and spurious signals.

You cannot create some threat scenarios, such as AoA, with a single-channel source. Those scenarios depend on properly synchronizing the outputs of two or more sources. By precisely controlling the amplitude, phase, and time delay of each source output, you can simulate the direction of a radar wavefront as it reaches the multiple antennas of an EW SUT. Accomplishing this feat with multiple signal generators scales up the cost, often resulting in redundant hardware — adding size, weight, power consumption, and complexity.

The Keysight UXG agile vector adapter works in conjunction with the UXG agile signal generator. Figure 16.16 shows the block diagram.

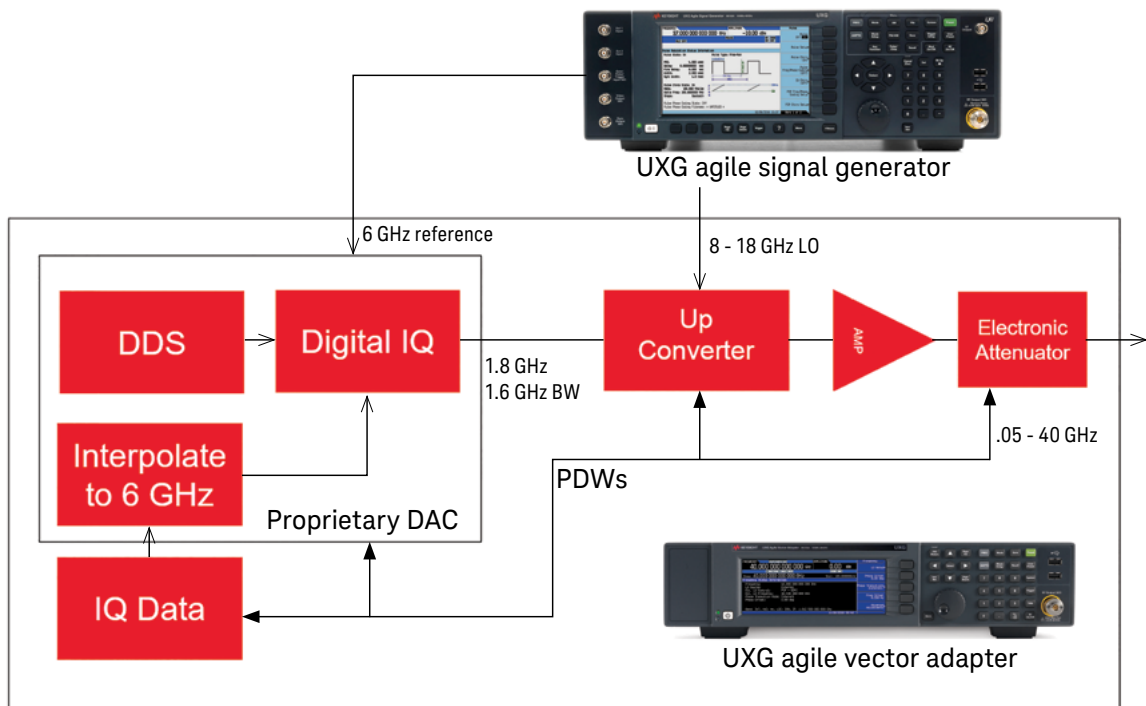

Figure 16.16. High-level block diagram of the UXG agile vector adapter

The vector adapter utilizes the 6 GHz reference and agile LO signals from the DDS source to avoid duplication of this hardware while adding a digital I/Q baseband system, upconverter, and electronic attenuator. The baseband generator memory stores the complex pulse waveforms represented by I/Q data points. This digital information feeds the DDS engine, where it is converted to an IF signal and upconverted to an RF frequency. An electronic attenuator provides agile amplitude scaling of the signal.

Minimizing Distortion

Traditional analog I/Q baseband systems must be carefully tuned to minimize signal distortion caused by phenomena such as IQ gain imbalance (where the gain in the I and Q channels is slightly different) and IQ skew (where the I and Q paths are not precisely in quadrature). Figure 16.17 (left image) shows how these imperfections create in-band distortion. these distortion products occur within the signal bandwidth, hence cannot be filtered out.

A digital baseband architecture mathematically shifts the I and Q channels by 90 degrees and digitally sums them before conversion to an analog IF signal. This technique greatly reduces the amount of in-band distortion. Figure 16.17 (right image) shows how this technique provides a higher fidelity signal.

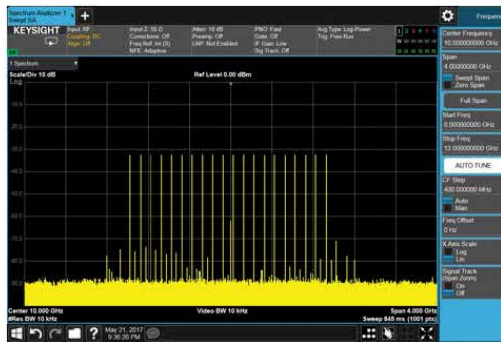

Analog baseband architecture

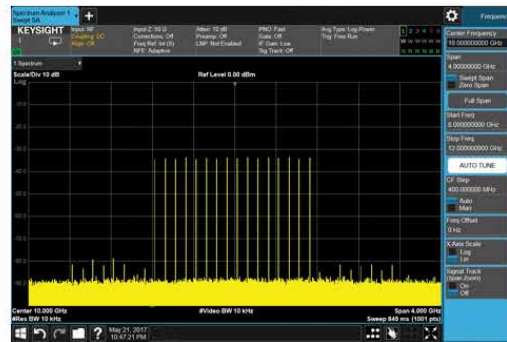

Digital baseband architecture

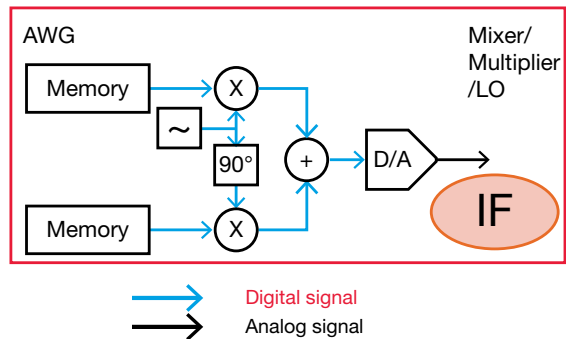
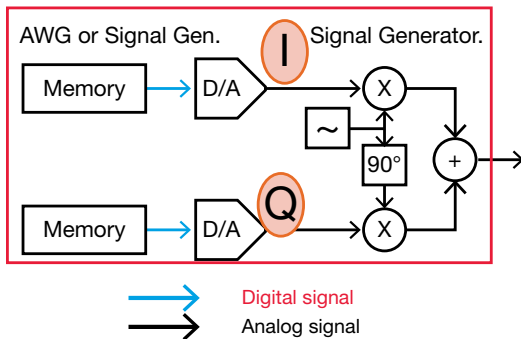

Figure 16.17. A comparison of analog and digital baseband architectures

Agile amplitude signal control is crucial for realistic threat simulation, where multiple emitters may be at different distances and transmit at different power levels. Mechanical attenuators cannot switch quickly enough to keep up with scenarios that potentially generate millions of pulses per second. To provide agile amplitude control, you can use the baseband generator's digital-to-analog converter (DAC) to scale the signal quickly. Depending on the vertical bits of resolution available in the DAC, this method can provide 40 to 55 dB of agile amplitude range.

This level of performance may impose severe limits on the threat scenario, which could require a higher, agile dynamic range. Moreover, the DAC technique for amplitude control cannot attenuate any spurious signals created further down the signal chain. The EW receiver under test must perform additional signal processing to determine if the detected signal is a genuine threat signal or a spurious one that can be ignored.

Configuring the Threat Simulation System

Depending on the SUT characteristics and the complexity of the desired threat scenario, you may need to configure the threat simulation system to support the differing channel and port counts. A channel refers to the ability to independently tune the threat signal to the desired frequency, while a port refers to the actual output port of the RF signal.

If the scenario requires large numbers of pulses at multiple frequencies with minimal dropped pulses, you might select the 4-channel, 1-port configurations in Figure 16.18. The outputs of each analog or vector source are combined to a single RF port.

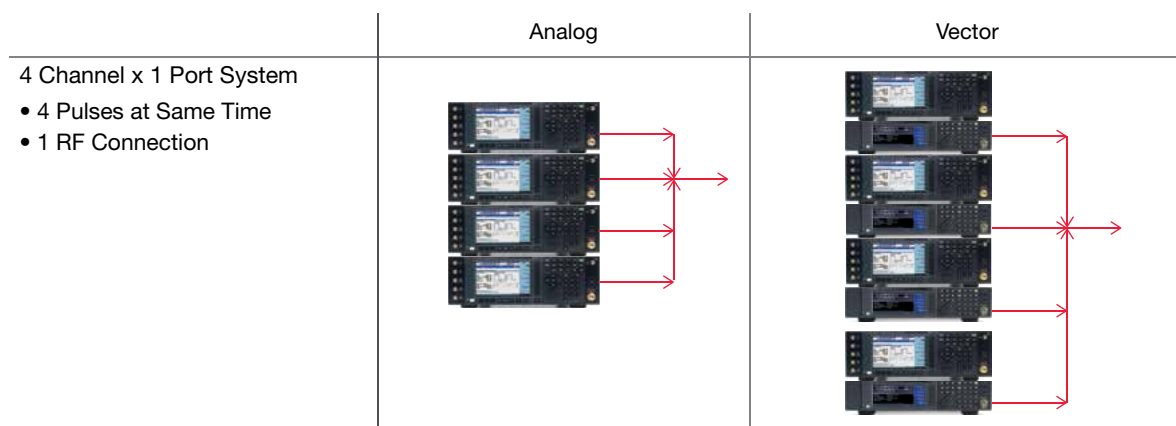

Figure 16.18. 4-channel, 1-port configurations

If the threat scenario calls for AoA measurements, you need a different configuration. Figure 16.19 shows two different 1-channel, 4-port test configurations. All four sources are tuned to the same frequency. But the amplitude, phase, and time delay of each RF output are individually controlled to simulate the direction of the threat.

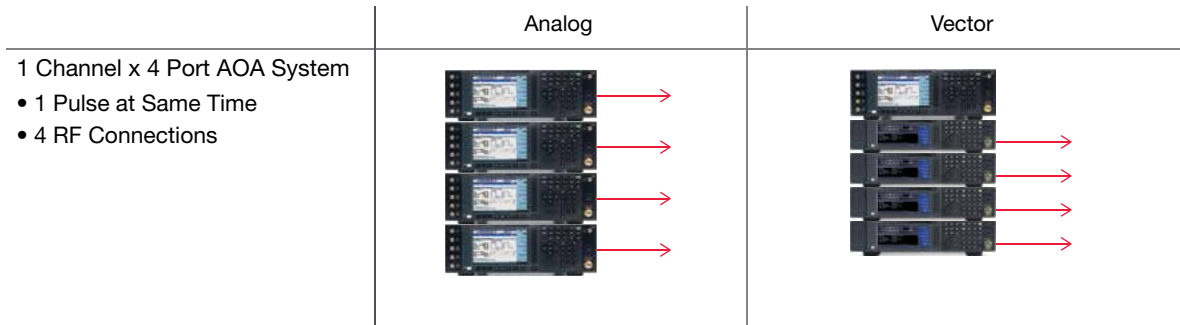

Figure 16.19. 1-channel, 4-port configurations

More complex scenarios may demand more extensive configurations, such as the 3-channel, 4-port setup in Figure 16.20. The three channels of this configuration provide high pulse density with pulse-on-pulse capability, as well as multiple ports for AoA testing.

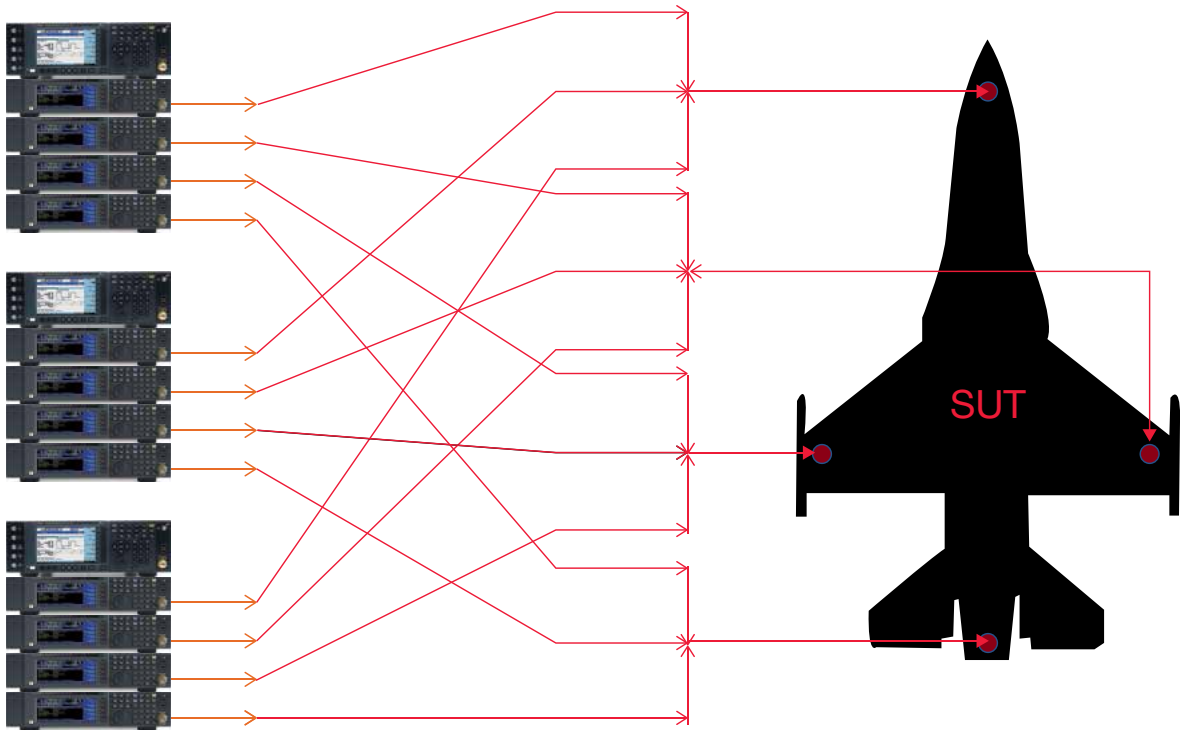

Figure 16.20. Configuration for 3-channel, 4-port

A variety of traditional technologies have been used to generate the signals needed for effective EW simulation. Each of these technologies has brought a different combination of benefits and challenges. The highest-fidelity solutions have provided realistic simulations of the EW environment, but their complexity and expense have limited their use.

Recent innovations in core hardware such as DACs and FPGAs have enabled new solutions with the hardware simplicity and reliability of traditional test equipment. These solutions will provide dramatic improvements in solution cost and size, bringing high-fidelity EW environment simulation to a much earlier phase in the design process. Using realistic EW environment simulation at the optimization and pre-verification stages of design will improve performance, speed the design process, and reduce overall costs.

References

1. Philip Kazserman, "Frequency of pulse coincidence given in n radars of different pulse widths and PRFs," IEEE Trans. Aerospace and Electronic Systems, Vol. AES-6, p. 657-662, September 1970.
2. Reproduced by permission from David Adamy, EW 101: A First Course in Electronic Warfare, Norwood, MA: Artech House, Inc., 2001. © 2001 by Artech House, Inc.

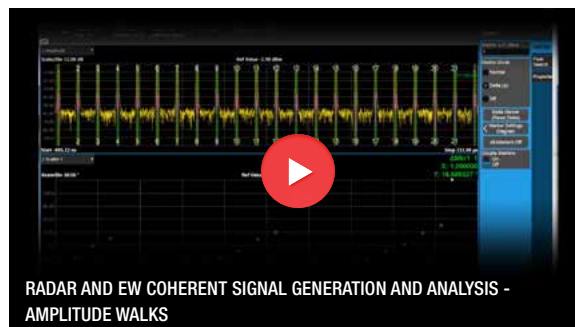

<https://www.keysight.com/see/radar-ew-subsystem-test>

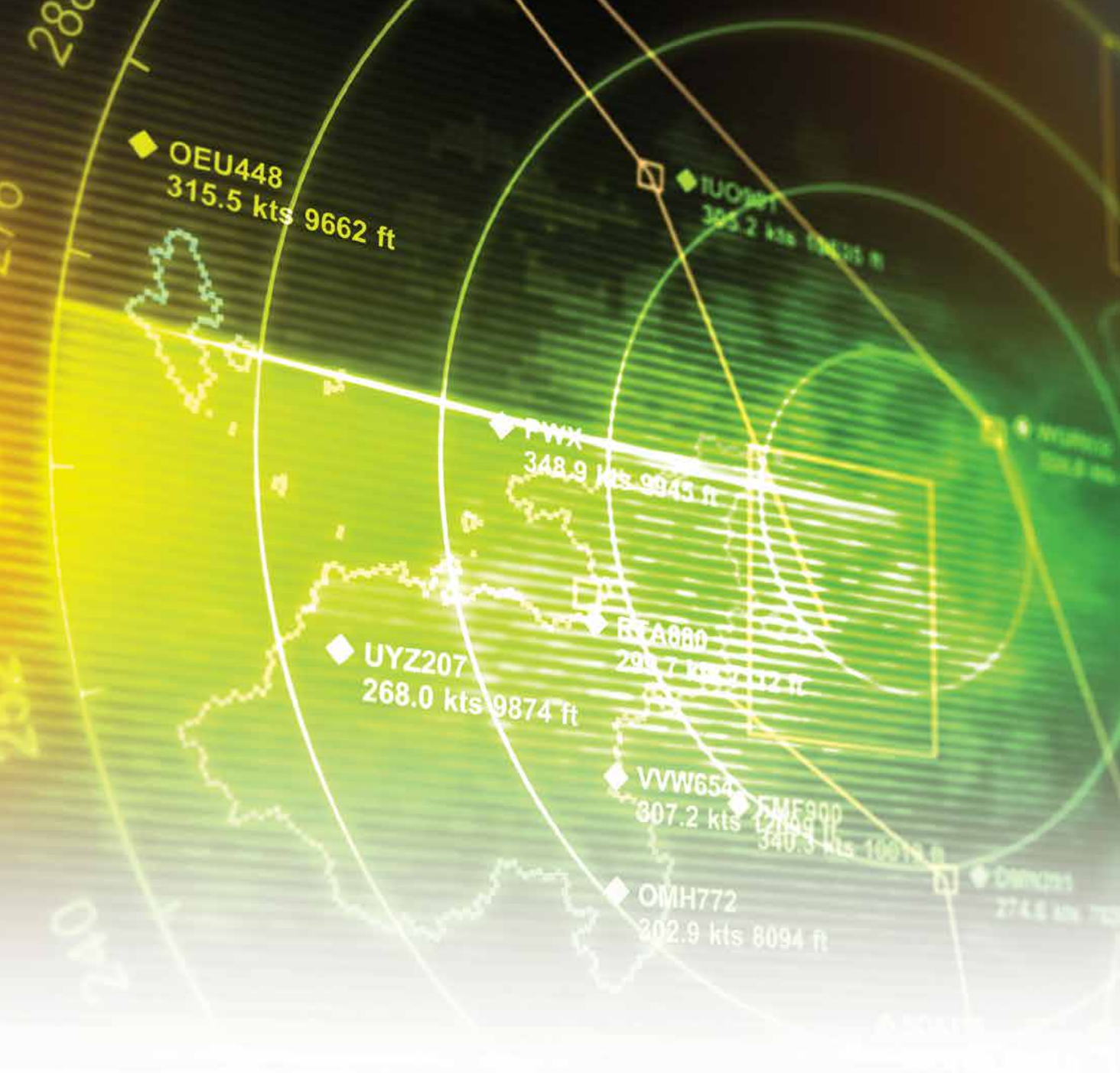

Chapter 17 Measuring Radar and EW Signals

A radar transmitter is the most costly component of the system with the highest power consumption, most stringent cooling requirements, and greatest influence on system performance.

There are many different terms used when talking about power, as shown in Figure 17.1. Average power is the power that is integrated over the complete time waveform (on time and off time) of the radar. If the pulse width and PRF are not constant, the integration time must be long enough to represent all possible variations in pulse parameters. Most typical RF and microwave power meters are average power meters and respond to the heating energy of the signal. Peak power is the maximum instantaneous power. Pulse power is the integrated or average power for one complete pulse.

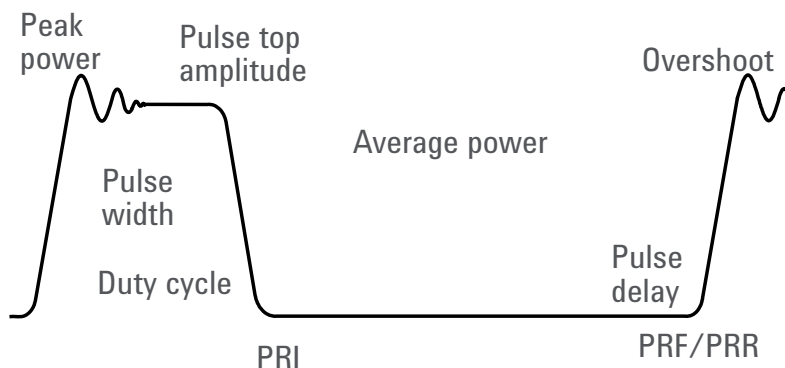

Figure 17.1. Pulse parameters

Other parameters, including duty cycle, pulse width, PRF, and rise and fall times as shown in Figure 17.1, are useful for characterizing the power of the radar signal.

From a radar equation standpoint, the power term corresponds to the power of the transmit pulse. If the integration term is excluded, the equation applies to a single pulse. Therefore, it can be useful to examine the peak and pulse power on an individual pulse basis. This technique is becoming more important for modern radar systems in which pulse width and PRF are dynamically adjusted and the pulse profile may be contoured to improve system performance. It is also becoming easier to perform with modern test equipment.

It should be noted that average power measurements are a common method for characterizing the power of a radar signal. These are simple to perform and require only low-cost instruments. If pulse characteristics, such as the duty cycle of the radar signal, are known, the pulse power can be derived or estimated based on average power. Note, however, that this derived result does not provide information about droop, or any peak excursions that may occur due to ringing or overshoot. The result would be nearly equivalent to the pulse-top amplitude, and in the case of a perfectly square pulse, it would be equivalent to the true peak power or pulse power.

Along with measuring power, the spectrum shape is critical to verifying that a radar system is operating efficiently. For example, an unsymmetrical or incorrect spectral shape indicates a radar that is operating less than optimally. In such cases, the radar may be wasting power by transmitting or splattering power at unwanted frequencies, causing out-of-band interference. For some radar systems, pulse shaping is used to reduce the level of the spectral sidelobes, to improve the efficiency and life of radar components, and to reduce bandwidth.

There are several options for measuring radar power, pulse characteristics, and spectrum including the use of a power meter, signal/spectrum analyzer, or vector signal analyzer. Because each instrument has advantages and limitations, the best choice is determined by the measurement objectives and the constraints on the radar and the test instrument. This section will describe how to make measurements with each of these instruments.

Maximum Instrument Input Level

One of the first things to consider is the magnitude of RF power that could be encountered. Parameters such as frequency, antenna match (SWR), pulse width (PW), pulse repetition time (PRT), and duty cycle will affect power measurements and selection of measurement hardware.

RF and microwave instruments are limited in both the amount of average power and the amount of peak power that can be input without damaging the instrument. For typical radar systems, with pulse powers of approximately 1 MW, a directional coupler is required to sample the transmitter power and provide a safe drive level to the test instrument.

Measuring Pulse Power with a Power Meter

The most common (and lowest-cost) way to measure pulse power is with a power meter. The right power meter can provide several measurements including average power, peak power, duty cycle, and even power statistics. One of the first things to consider when measuring with a power meter is the power sensor.

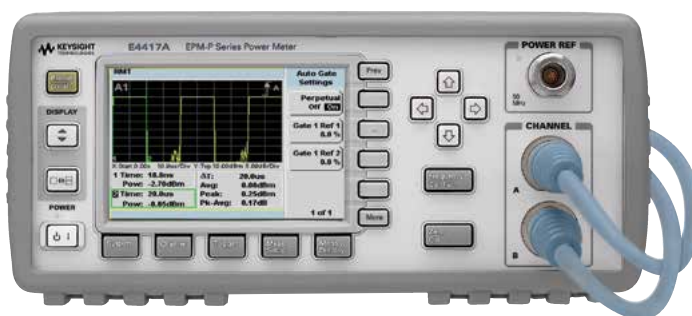

Figure 17.2. P-Series power meters

The power sensor

The power sensor converts high-frequency power to a DC or low-frequency signal that the power meter can then measure and relate to a certain RF or microwave power level. The three main types of sensors are thermistors, thermocouples, and diode detectors. There are benefits and limitations associated with each type of sensor. Many of today's average power measurements require a dynamic range greater than 50 dB. Keysight's approach to meeting this need is to create an average power sensor with a wide dynamic range that incorporates diode stacks in place of single diodes to extend square-law operation to higher power levels (at the expense of sensitivity).

Measuring power with an average power meter

An average power meter can be used to report average power and pulse power if the duty cycle of the signal is known. There are some advantages to using this method but there are also several points that must be taken into consideration. When an average power meter reports a pulse or peak power result, it does so by deriving the result from the average power and a known duty cycle. The result is accurate for an ideal or nearly ideal pulse signal but it does not reflect aberrations due to a nonsquare pulse shape and will not detect peak excursions that may result from ringing or overshoot. The main advantage of average power meters is that they are the lowest-cost solution. Both the power meters and sensors are less expensive than the corresponding peak power meters and sensors. They also generally can measure over a wider dynamic range, frequency range, and bandwidth, and can measure a signal no matter how fast the rise time or narrow the pulse width.

Measuring power with a peak power meter

The peak power meter with a sensor has the advantage in that it is capable of making direct measurements of peak power and pulse power. This is particularly useful for shaped or modulated pulses for which deriving pulse power from average power may be inadequate.

Figure 17.3 shows an example of measuring peak and pulse power using the Keysight P-Series peak power meter. A convenient feature of the meter is its trace display, which allows you to view the envelope of the pulse signal that is being measured. The meter operates by continuously sampling the signal with a 100 MS/s digitizer, buffering the data, and calculating the result. This gives the meter greater measurement versatility, including flexible triggering, time gating with multiple gates, and the ability to take single-shot measurements.

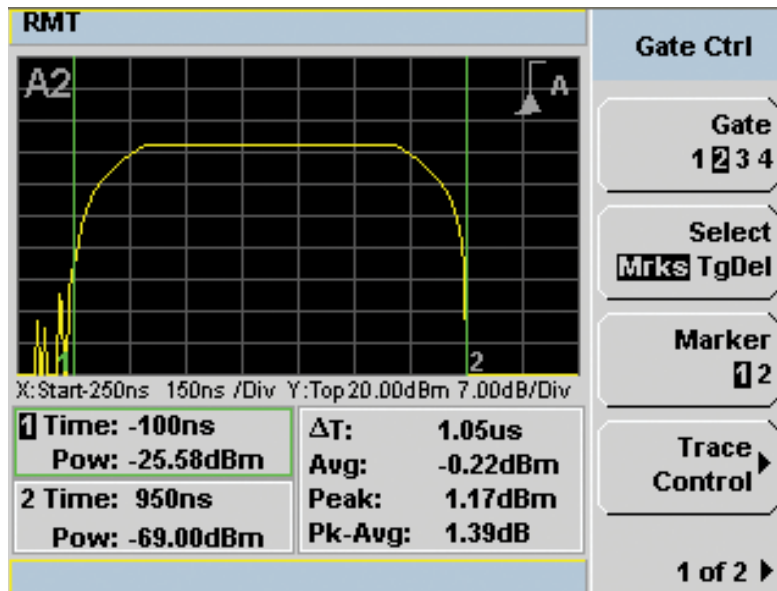

Figure 17.3. Using the P-Series peak power meter to measure peak power, gated pulse power, and peak-to-average ratio. Due to the shape of this pulse the peak power is 1.39 dB higher than the pulse power.



Figure 17.4. P-Series power meters and power sensors

Keysight power meters operate with various sensors (CW, average, and peak and average) and cover numerous frequency and power ranges to accurately measure the power of RF and microwave signals. Keysight P-Series wideband power meters (30 MHz video bandwidth) such as the N1911A (single-channel) and N1912A (dual-channel) provide measurements including peak, peak-to-average ratio, average power, rise time, fall time, and pulse width.

When used with an N1921A or N1922A wideband power sensor, an N1911/12A P-Series power meter provides a measurement frequency range of 50 MHz to 40 GHz.

Pulse Frequency and Timing Measurements with a Counter

Recently advanced counters with pulsed RF/microwave measurement capabilities have reappeared in test and measurement product lines. These advanced counters provide a low-cost solution that is easily configured for pulse frequency (PF), pulse width (PW), pulse repetition frequency (PRF), and pulse repetition interval (PRI) measurements. Within a counter, the internal measurement engine is an advanced event timer. Instead of digitizing a signal—as in an oscilloscope—the counter makes measurements by triggering off a start event such as the rising or falling edge of a signal, at a specified amplitude. Once the start trigger occurs, a timer is started and runs until a specified stop event trigger is reached.

Using a method known as interpolation, accurate timing measurements with sub-nano-second resolution can easily be obtained.



Figure 17.5. Frequency counter

Measuring Pulse Power and Spectrum with a Signal/Spectrum Analyzer

The primary advantage of a signal analyzer is that it can measure the frequency content of the radar in addition to power. This is important because an incorrect spectrum can indicate several problems that result in wasted power and the emission of unintended signals. In general, an improper spectral shape indicates a radar that is operating less than optimally. For example, Figure 17.6 shows radar signal spectra before and after adjustment to the cross-field amplifier used for the radar transmitter. The symmetry of the spectrum indicates an optimally performing radar.

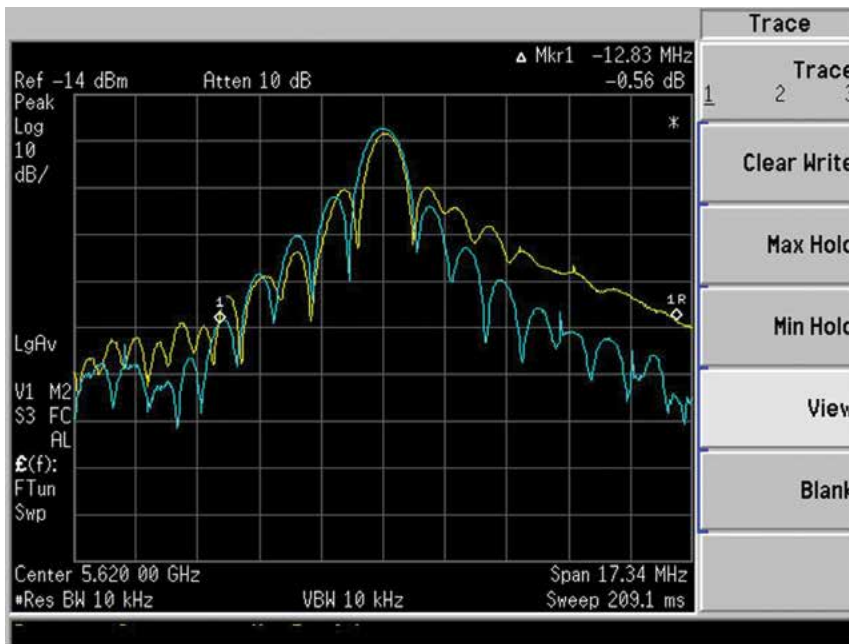

Figure 17.6. A signal analyzer is useful for examining the shape and symmetry of the radar spectrum. This example shows the spectrum trace before and after a timing adjustment in the magnetron.

Measuring pulsed radar with a signal analyzer is complicated by the different modes of operation that occur, which depend on the resolution bandwidth (RBW) setting of the spectrum analyzer. These variations exist when measuring any type of pulsed signal but tend to be more noteworthy when measuring the low-duty-cycle pulses commonly used with radar signals. Further, different modes in signal analyzers, namely swept versus fast Fourier transform (FFT), can behave differently when measuring pulsed signals.

This section starts with a quick review of the basic spectral shape of a simple pulsed RF signal. Next, it will examine the measurement of radar with both swept-based and FFT-based signal analyzers (including different measurement modes) and then conclude with a survey of the different built-in measurement functions included in many of today's analyzers.



Figure 17.7. PXA series high-performance signal analyzers

Pulse spectrum review

In the time domain, multiplication of a continuous wave signal by a pulsed waveform results in a pulsed carrier. The spectrum of a pulsed signal forms a characteristic sinc function shape with a main lobe and sidelobes. From a mathematical standpoint, this can be understood by taking the Fourier transform of a rectangular waveform and then translating it to the frequency of the carrier.

As can be seen in Figure 17.8, the pulse width and PRF of the signal determine the characteristics of the basic pulsed spectrum. As the pulse width narrows, the width of the spectrum and sidelobes broadens. The PRF of the pulsed-RF waveform determines the spacing between each spectral component. Viewing the spectrum of the pulse can therefore provide meaningful information about the signal's pulse width, period, and duty cycle. For a basic pulsed-RF signal, the duty cycle can then be used to calculate the peak pulse power from the average power and vice versa.

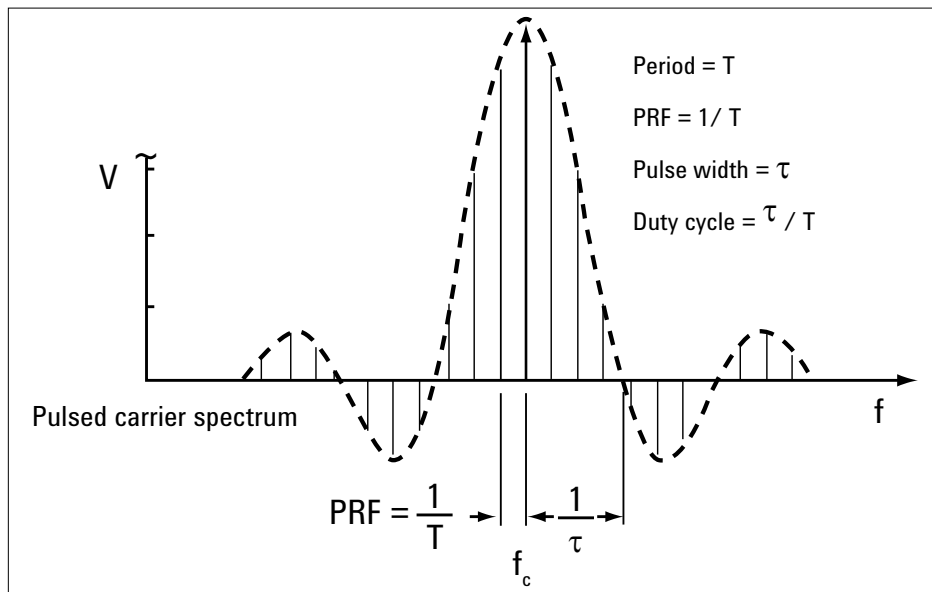

Figure 17.8. Pulsed spectrum

Pulsed RF measurements with a swept spectrum analyzer

Conventional spectrum analyzers are based on analog super-heterodyne swept architectures. Most modern instruments such as the Keysight PXA Series high performance signal analyzer or MXA midrange signal analyzer employ a digital implementation of a swept architecture. This approach has many benefits in speed and accuracy over their analog counterparts. Other spectrum analyzers may work by calculating an FFT. Still others, including the PXA and MXA, employ both techniques. Each has its advantages. For example, swept analyzers usually have the best dynamic range while FFT analyzers are likely faster for computing in-channel measurements. Other differences, as they relate to measuring pulsed radar signals, will be outlined below. One advantage of a swept architecture is that most RF designers are familiar with its operation. That familiarity results in an intuitive understanding of signals from their swept spectrum measurement that is lost in a snapshot FFT spectrum.

Pulsed RF measurements with analyzers that compute FFT

As mentioned above, some signal analyzers use FFT to compute spectra in a manner similar to that of a VSA. Analyzers that use FFT techniques have advantages and disadvantages when compared to swept analyzers. Swept analyzers have advantages in sensitivity and wide-span measurements. FFT analyzers can be faster for measuring radars with bandwidths less than the analyzer's maximum FFT analysis bandwidth. FFT based signal/spectrum analyzers can also perform VSA measurements (if the software is implemented) because phase information is maintained. However, for reasons covered below, FFT analyzers tend to be inadequate for measuring wideband radar or radar with low duty cycles. Some spectrum analyzers such as the PXA and MXA include both swept and FFT modes and automatically switch between them depending on measurement settings. The analyzer can be set to automatically optimize for speed or dynamic range or forced to remain in either FFT or swept mode.

FFT-based spectrum analyzers typically have a user interface designed to have a look and feel similar to that of a traditional swept analyzer. A casual user may not even recognize that they are using FFT techniques rather than traditional spectrum sweeps. However, the differences become apparent when measuring pulsed RF signals.

Like a vector signal analyzer, the FFT-based spectrum analyzer can be fast at measuring signals whose entire bandwidth is contained within a single FFT (i.e., contained within its analysis bandwidth). With this condition met, the FFT signal analyzer is essentially equivalent to a VSA though typically without as many measurement functions and displays.

When the span of interest is wider than the analysis or FFT bandwidth of the analyzer, the FFT-based spectrum analyzer calculates the spectrum by taking multiple FFTs at different frequencies and concatenating the results. This technique is sometimes called stitching because the analyzer computes the spectrum one section at a time, step tuning to a different frequency for each section, and patching them together. Depending on the speed of the analyzer, one may be able to see each section of the spectrum appear as it is computed.

If the condition for line-spectrum mode is met ($PRF < 0.3 RBW$) then there is no difference in the result for the traditional swept or FFT analyzer. However, if these conditions are not met, FFT-based analyzers will behave quite differently than swept analyzers. In this case, the FFT analyzer will not display the PRF lines seen in the swept analyzer. Rather, the data displayed will depend on the probability of intercept between the FFT acquisitions and the pulses.

Built-in measurements

Today's modern spectrum analyzers include many built-in functions and capabilities that can simplify and enhance radar measurements. Several of these features are highlighted here.

Channel-power

The channel-power function is designed to measure the average power across a given frequency band. It is a common measurement that is frequently used to measure many different types of signals. Spectrum analyzers use different techniques for making channel-power measurements. The most common way, which is usually the most accurate, is the integration bandwidth method. The analyzer essentially integrates the power as it sweeps across the given integration bandwidth. Typically, the measurement uses the analyzer's averaging detector. Examples of channel-power measurements of a radar signal are shown in Figure 17.9.

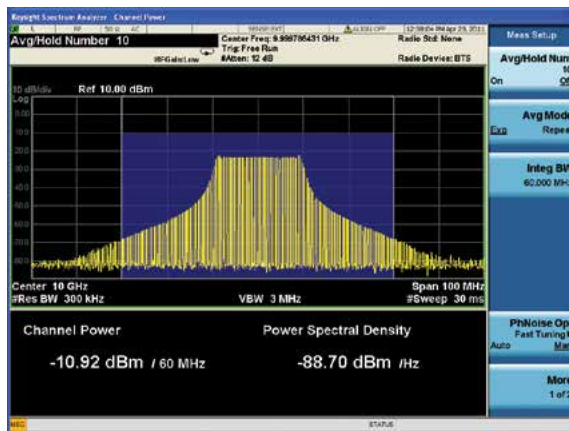

Chirped radar

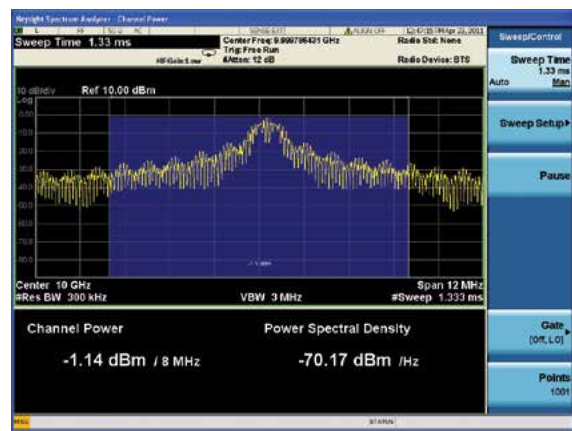

7-bit Barker code

Figure 17.9. Channel power measurement of radar signals performed on a spectrum analyzer. Results are equivalent to average power.

Occupied bandwidth

The occupied bandwidth (OBW) measurement automatically calculates the bandwidth in which a specified percentage of the power is contained. The OBW of the signal is often determined based on the bandwidth for which 99% of the signal's power is contained, as shown in Figure 17.10.

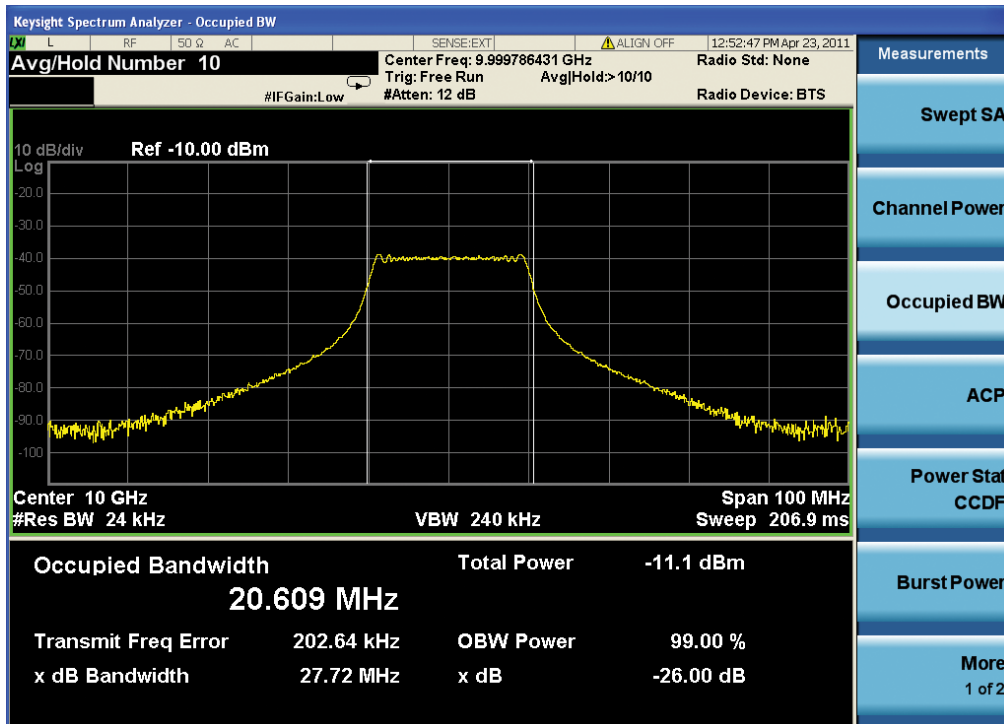

Figure 17.10. This is an example of an occupied bandwidth measurement on the PXA spectrum analyzer.

Bandwidth for which 99.00% of the signal power is contained is automatically measured and reported.

Burst-power

The burst-power measurement is an automated zero-span measurement. Rather than integrating the power in the frequency domain (as is done in the channel- power measurement) the burst-power measurement integrates the power across a defined time slot or gate and is essentially equivalent to the gated power measurements discussed earlier in the power meter section. The measurement often uses a burst-power trigger (provided on some signal analyzers such as the PXA) that automatically finds and triggers on the burst (or pulse), as shown in Figure 17.11. This can be very useful for radar because it is a direct measurement of the pulse power. Its limitations, however, are the same as those for zero span: the RBW filter must be wide relative to the occupied bandwidth of the signal.

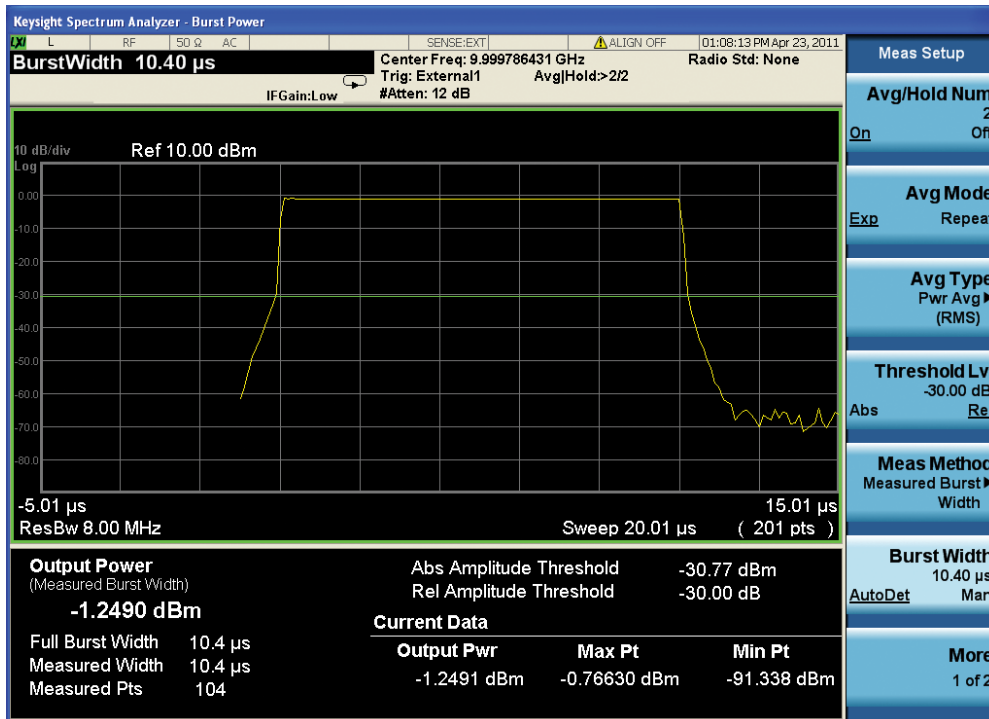

Figure 17.11. This is an example of burst-power measurement from the PXA signal analyzer. Burst power and pulse width are automatically measured in zero-span mode.

Measuring with a Vector Signal Analyzer

Unlike a spectrum analyzer, a vector signal analyzer captures the phase and magnitude information of the measured signal and uses this information to perform more advanced analysis. Vector signal analyzers are typically very flexible and can display results in the time, frequency, and modulation domains.

A vector signal analyzer does not sweep across a wide frequency range like a spectrum analyzer. Most vector signal analyzers operate by tuning to a specific frequency, conditioning the signal, down-converting, digitizing, and processing the signal. Some vector signal analyzers skip the analog down-conversion stage and directly digitize the baseband, IF, or even RF signal after conditioning.

There are a variety of vector signal analysis solutions available with varying performance constraints and tradeoffs in bandwidth, sensitivity, memory, and frequency range. Many of today's modern instruments include dual functionality and operate as both a spectrum analyzer and a vector signal analyzer, as is the case with the Keysight X-series and PSA analyzers, or as an oscilloscope and vector signal analyzer. Keysight VSA software can also be extended to work with logic analyzers to analyze signals in digital form or to work in software simulation environments such as Keysight ADS or MATLAB.

Explore Your Signal Vector Mode

Even with basic VSA, one can learn much about their signal in Vector mode, which enables time domain and frequency domain visualizations.

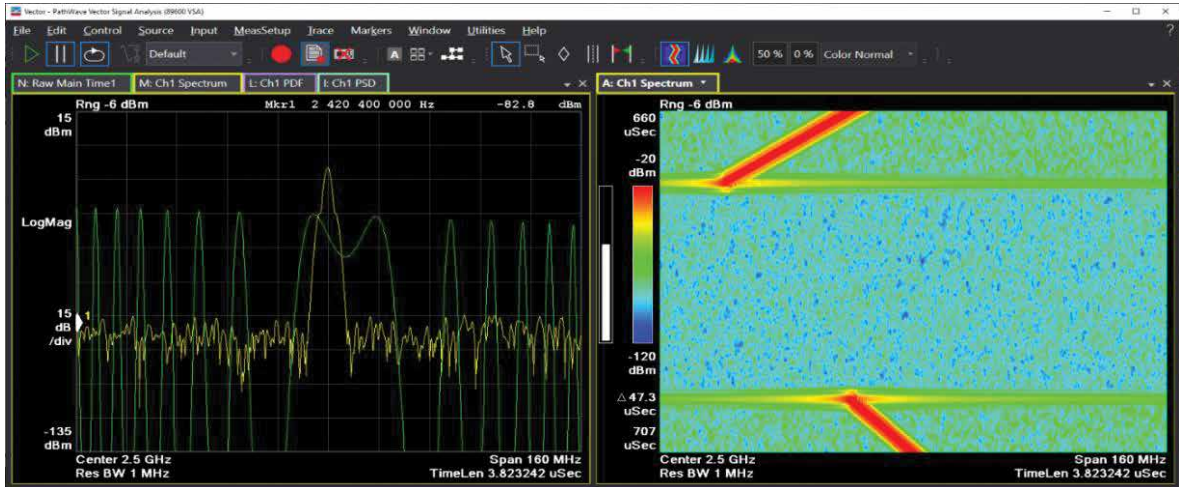

Figure 17.12 Time and frequency domain representation of chirp signal(left). Spectrogram view (right)

Radar Pulse Analysis

With the radar pulse analysis measurement extension, pulse boundaries are automatically detected with advanced algorithms. A Swiss Army knife of tools becomes available, including new trace types, statistics, measurements, and table metrics that are all specifically tailored for pulse analysis.



Trace Types - Here we show instantaneous frequency and instantaneous phase versus time. Furthermore, based on a best fit analysis of instantaneous frequency, deviations from the best fit are plotted as "FM Error vs Time."

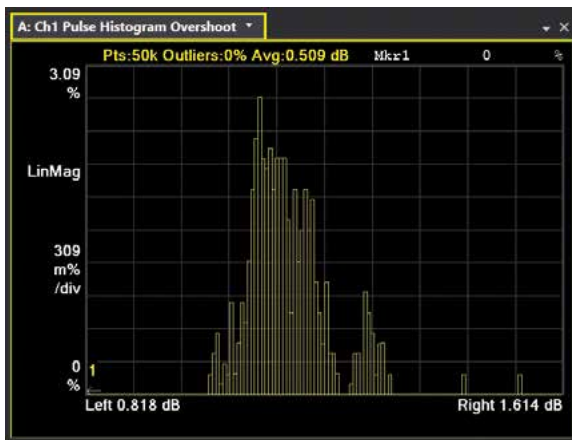

Statistics - Any metric that may be tabulated in a pulse table may be analyzed in terms of its statistics and trendlines. In this case, the amplitude envelope overshoot is plotted as a histogram. This way RF system engineers can answer the question, "How accurate and repeatable were my pulses?"

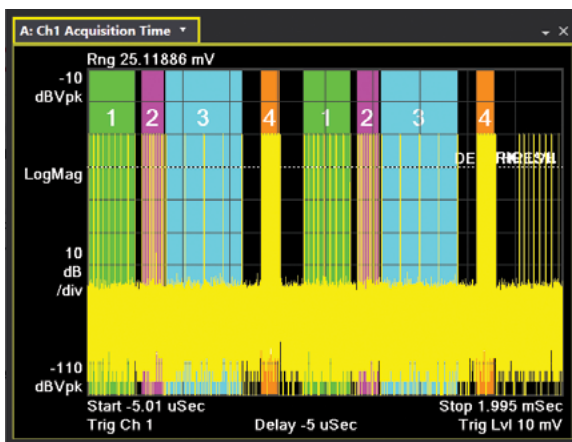

Measurements - Certain workflows require specialized measurements. Some examples include the analysis of pulse sidelobes and pulse compression; angle of arrival; or even pulse pattern search. In this illustration, we present various pulse trains that have been recognized and color-coded appropriately.

Figure 17.13. Trace types, statistics and measurements



Figure 17.14. All-in-one view in single window of VSA software

All three elements (trace types, statistics, and measurements) are shown above with highly configurable windows. Four pulses (4 through 7) are highlighted and aligned with their corresponding time-domain traces. A histogram of the rise time, the trend line of the pulse fall time, and an overall pulse summary are also included. Along the bottom, detailed pulse metrics are tabulated across the 40 pulses detected.

How Accurate and Repeatable were my Pulses?

Since pulses may span many gigahertz of frequency, large data sets must be analyzed to identify individual pulses and quantify various figures of merit. With the option 89601BHQC, pulses are automatically identified, labeled, and cataloged in pulse tables.

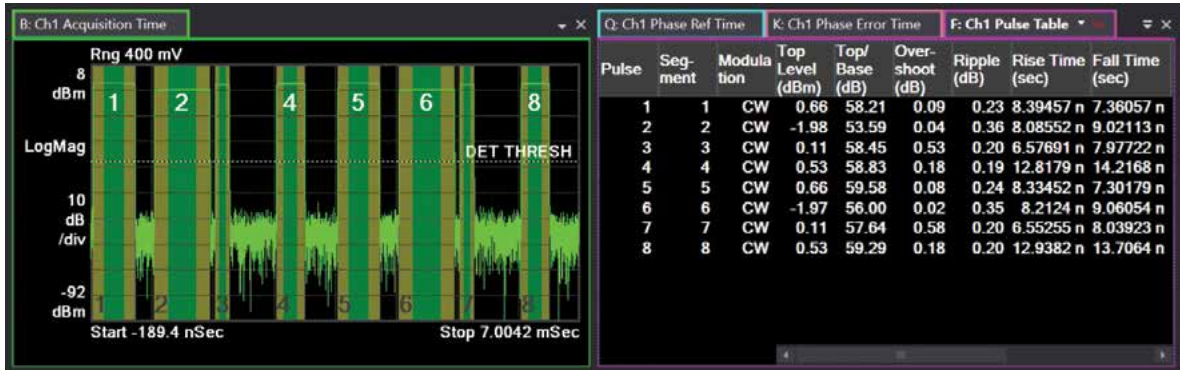

Figure 17.15. Pulse table

The power, frequency, amplitude, and phase vs. time are carefully analyzed for each pulse to calculate figures of merit that can be tabulated in a pulse table (Figure 17.15). Example metrics are pulse width (PW), pulse repetition interval (PRI), rise time, fall time, and amplitude overshoot illustrated below.

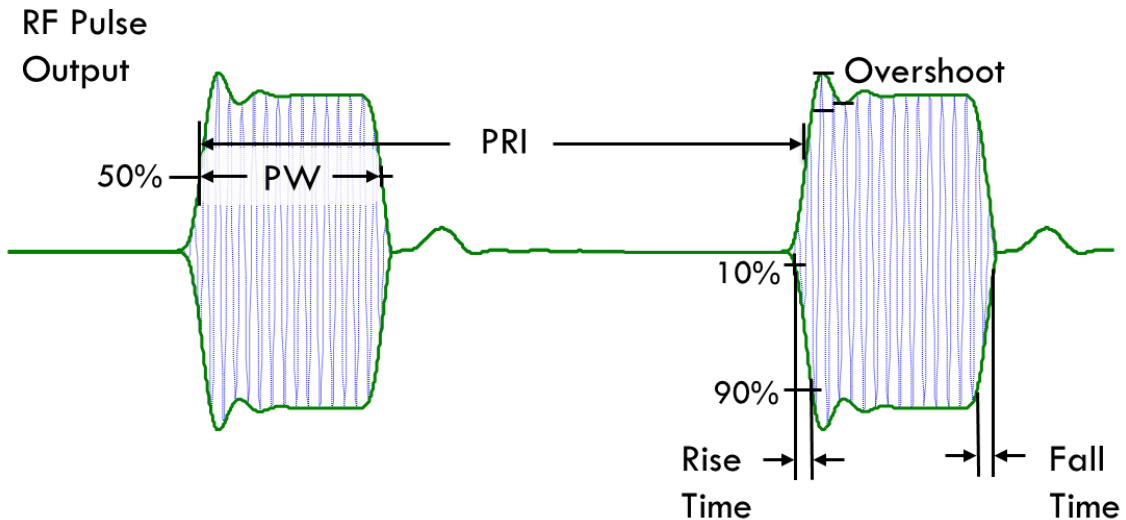

Figure 17.16. RF pulse output

Numerous other metrics are organized in the following categories:

- Modulation Metrics – modulation type, modulation code number, chip count, measured bits, chip width, chip offset
- RF Output Level Metrics – top level, base level, top to base ratio, amplitude when the pulse is on, peak level, mean level, peak to average ratio
- Amplitude Settling Metrics – pulse droop, droop rate, droop starting amplitude, droop ending amplitude, overshoot, ripple
- Time Metrics – rise time, fall time, rising edge, falling edge, width, duty cycle, pulse repetition frequency, pulse repetition interval, off time
- Frequency Metrics - mean frequency, pulse to first pulse frequency difference, peak-to-peak frequency deviation, and relative to an estimated reference signal, RMS frequency error, peak frequency error, and time location of peak frequency error
- Phase Metrics – mean phase, pulse to first pulse phase difference, peak to peak phase deviation, and relative to an estimated reference signal, RMS phase error, peak phase error, and time location of peak phase error
- Linear Frequency Modulation Metrics – best-fit mean modulation frequency, best-fit start modulation frequency, best-fit ending modulation frequency, best-fit peak-to-peak modulation frequency deviation, best-fit FM slope, integrated nonlinearity from best-fit
- Triangular Frequency Modulation Metrics – best-fit apex frequency, best-fit apex time
- Channel to Channel Difference Metrics – time, amplitude, and frequency difference of a corresponding pulse on channel 2 as compared to Channel 1
- Pulse Compression Metrics – correlation between reference pulse and measured pulse; peak sidelobe level, peak sidelobe location, compression ratio, main lobe width
- Deinterleaving Metrics – emitter ID
- Frequency Hopping Metrics – hop state index, hop begin time, hop ending time, hop settling time, hop dwell time, hop switching time, hop mean frequency, hop mean frequency deviation

Any of these metrics may be copied to Microsoft Excel or exported to CSV format for further analysis.

Furthermore, statistics and trends on any of these metrics may be visualized. Hypothetically, a radar engineer may have a large population of pulses that are supposed to have the same pulse width or pulse repetition interval. The repeatability of the RF system may be plotted using a histogram.

Below we show a histogram of pulse repetition interval using an MXG signal generator. Judging by the limits of the x-axis, we observe very little variation in PRI.

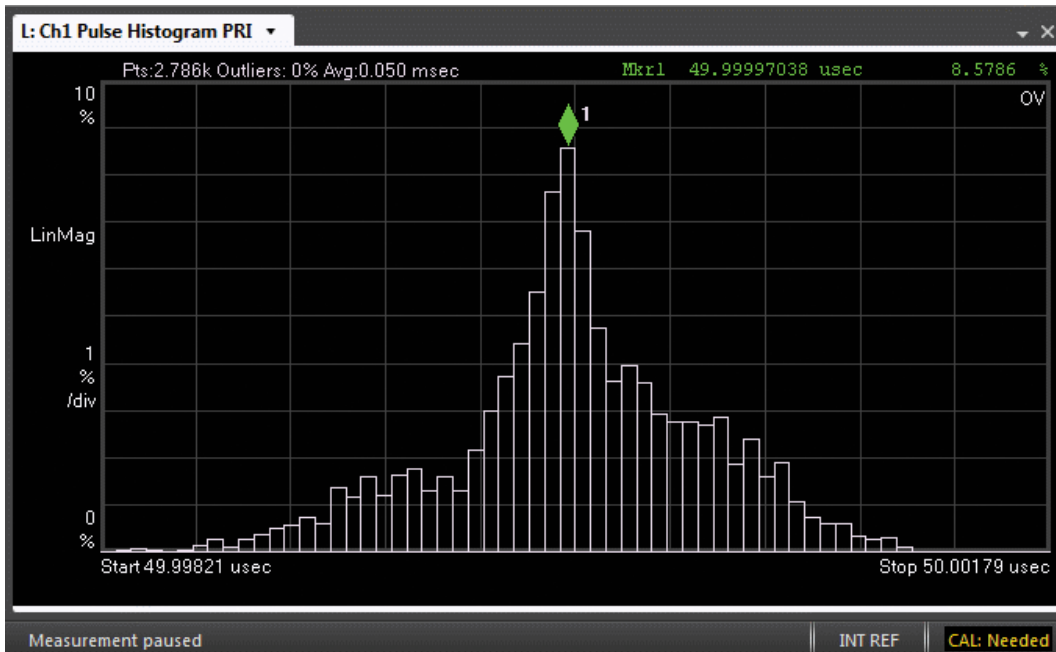

Figure 17.17. Pulse histogram

Evaluate Modulation on Pulse

A real-world signal might be hopping in frequency and modulated in different ways. We will need to automatically identify frequency modulation and modulation code. Fortunately, the VSA enables automatic pulse modulation recognition in the pulse results table, even providing decoded bits in some cases.



Figure 17.18. Modulation types

A small subset of the possible modulation types is shown in Figure 17.18. A more complete list includes the following types: Continuous Wave, Linear FM, Triangular FM, Barker Phase, BPSK, QPSK, Frank Code, P1 Code, P2 Code, P3 Code, and P4 Code. Furthermore, Bipolar Phase Shift Keying (BPSK) modulation may be defined from 0° to an arbitrary phase, including the most typical 180° .

In larger test systems, trigger events may arrive intermittently, with significant pauses in between trigger events. In such cases, it is helpful to tabulate pulse metrics across trigger events and individual acquisitions. For these scenarios, the pulse table may be configured as a cumulative pulse table in that rows describing groups of pulses may come from different acquisitions.

Characterize Angle of Arrival with Segmented Acquisitions

In situations where the duty cycle can be very small, much of the high precision and high bandwidth IQ data captured is wasted. As an illustration, let's assume a pulse width of $1\ \mu\text{s}$ but with a pulse repetition interval of $1\ \text{ms}$, implying a duty cycle of 0.1% . Graphically, this is not very informative as may be seen in Figure 17.19.

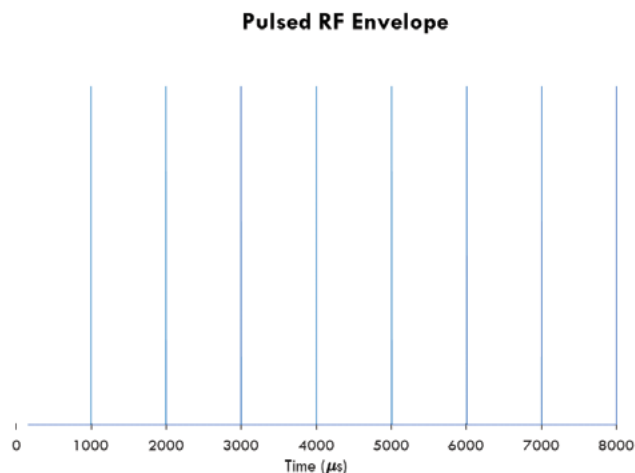

Figure 17.19. Pulsed RF envelope

However, if we enable segmented capture, much of the dead time may be eliminated, allowing a closer look at the most salient characteristics of the pulse, like overshoot or ringing.

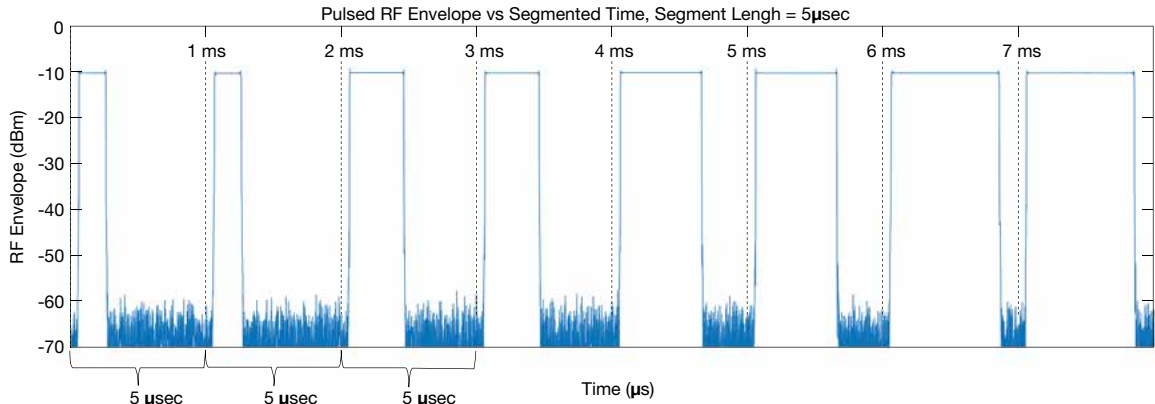

Figure 17.20. Segmented capture of pulse

By leveraging segmented capture measured across four oscilloscope channels, scan patterns across four antennas may be characterized over tens of seconds as shown in Figure 17.21



Figure 17.21. Segmented capture across four channels

Once the antenna spacing and location have been specified, angle of arrival (AoA) calculations may be completed using one of two methods: noting phase differences or the time difference of arrival (TDOA) between channels. Below, a trend plot shows the evolution of elevation and azimuth across pulses (Figure 17.22)

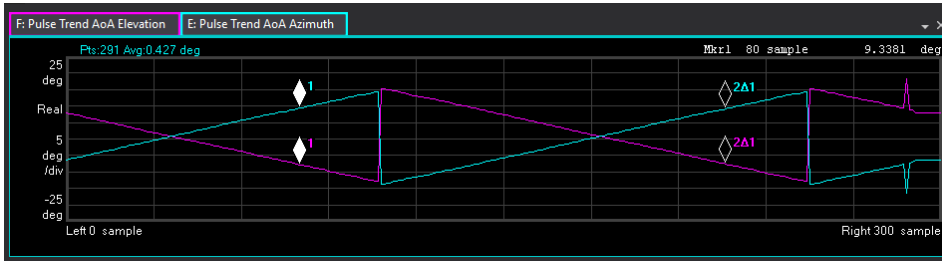

Figure 17.22. Trend plot showing AoA elevation and azimuth

Quantify Pulse Compression and Linear FM

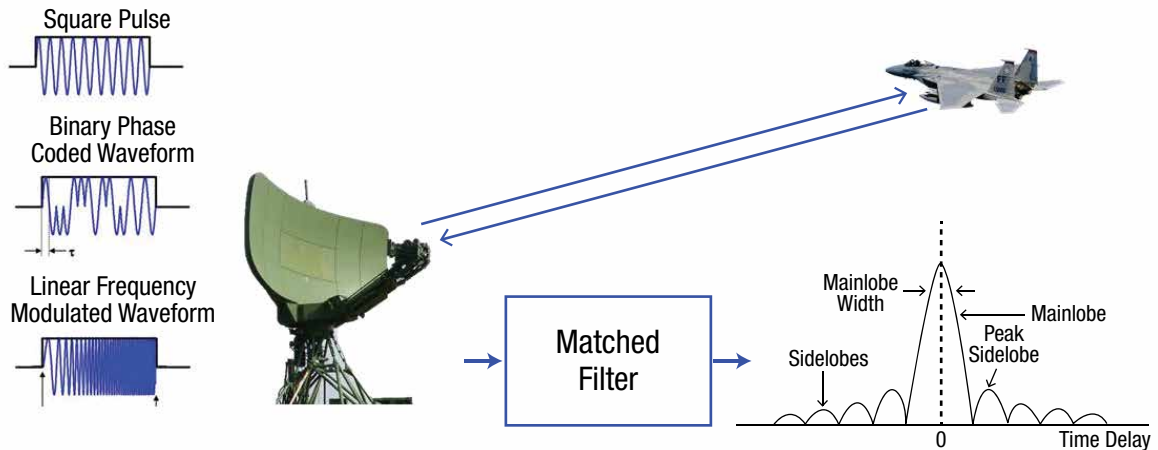

Figure 17.23. Pulse compression

Radar works by sending out a loud pulse and then listening for the echoes of that outbound pulse. In other words, we judge the distance of an object by reflecting a signal off it. By noting the arrival time of the echoes and accounting for the speed of propagation, we can estimate the distance or “range” of the object. Furthermore, by noting the frequency shift of the echoes, we can also gauge the velocity. By changing the shape of the outbound pulse in a specially designed way, the distance resolution and immunity to ambient noise can be improved with the help of a matched filter. Thus the received signal is submitted to a filter that is simply a time-reversed version of the original signal. This is the same as taking the correlation of the original signal. Any echoes off real objects will have the same shape as the outbound signal, and so the convolution of the received signal against the time-reversed outbound signal leads to taller and narrower peaks, which is great for range resolution. System noise or radar clutter will not have the same signature as the outbound signal, so after taking the correlation against the outbound pulse, it continues to look like noise.

With the VSA, the matched filter is specified by choosing a pulse as a reference pulse and saving its shape to a data register. Pulse compression may then be evaluated in terms of the agreement between measured pulses and reference outbound pulse; sidelobe height and time offset; and main lobe width as compared to the overall pulse width (or compression ratio). These are tabulated as metrics in the pulse table.

By the 1950s, the industry had wholeheartedly embraced this concept of pulse compression, and people were looking at improved ways of having sharper main lobes with lower sidelobes. Both experimentally and theoretically, they learned that a wider bandwidth signal leads to lower sidelobes and taller main lobes. The most common approach is to apply linear frequency modulation to the pulse. To achieve even higher levels of pulse compression, radar engineers have explored “non-linear frequency modulation” or NLFM, typically characterized as a polynomial fit to the frequency versus time data.

While some would argue one is a superset of the other, the VSA can analyze both types, returning the polynomial fits to the instantaneous frequency versus time in the case of NLFM. Linear FM metrics are tabulated in the pulse results summary table. For every pulse that has a linear FM chirp, the VSA implements a best-fit to the measured frequency versus time data to estimate what would be the instantaneous frequency versus time if we were looking at a perfectly linear modulator. Deviations from this best-fit are then tabulated.

Getting Data into the VSA

What type of hardware instrumentation is well-suited for radar pulse analysis?

Many radar system engineers require tremendous instantaneous bandwidth because no one knows precisely what frequency the pulses will be arriving. In such situations, we would recommend a broadband oscilloscope with up to 110 GHz of instantaneous bandwidth. Whereas typically super-wide bandwidth oscilloscopes have presented poor dynamic range with the full bandwidth of noise degrading the measured signal-to-noise ratio, this trade-off is not necessary today. The Infiniium UXR scope features hardware-accelerated decimation and filtering.

Some radar engineers are trying to find a relatively small signal hidden in the noise of a dynamic spectrum. In that case, we would recommend a state-of-the-art spectrum analyzer like the UXA with dedicated hardware to provide the best possible dynamic range.

Lastly, for a radar engineer on a test range interested in looking for intermittent aberrations in the electromagnetic airspace, they will be interested in collecting huge amounts of data and saving it to robust hard drives without any gaps between acquisitions. In that case, we would recommend a streaming digitizer such as the M8131A with an optical interface to provide adequate data throughput.

The VSA connects to all three classes of instruments and provides a hardware extension to over 300 Keysight model numbers allowing an engineer to test anywhere in the transmitter chain, from the DSP with a logic analyzer, to the baseband inputs with an oscilloscope, and the RF output with a signal analyzer. Once a connection has been established, the software feels like an extension of the instrument,

allowing the user to set center frequency, sample rate, trigger on RF bursts of power, and even record acquisitions to a binary file for post-processing. Furthermore, connectivity to third-party receivers may be developed using the 89630B Software Development Kit (SDK) and then leveraged with the 89601300C option. The most typical method for getting data into the VSA is by way of a hardware connection.

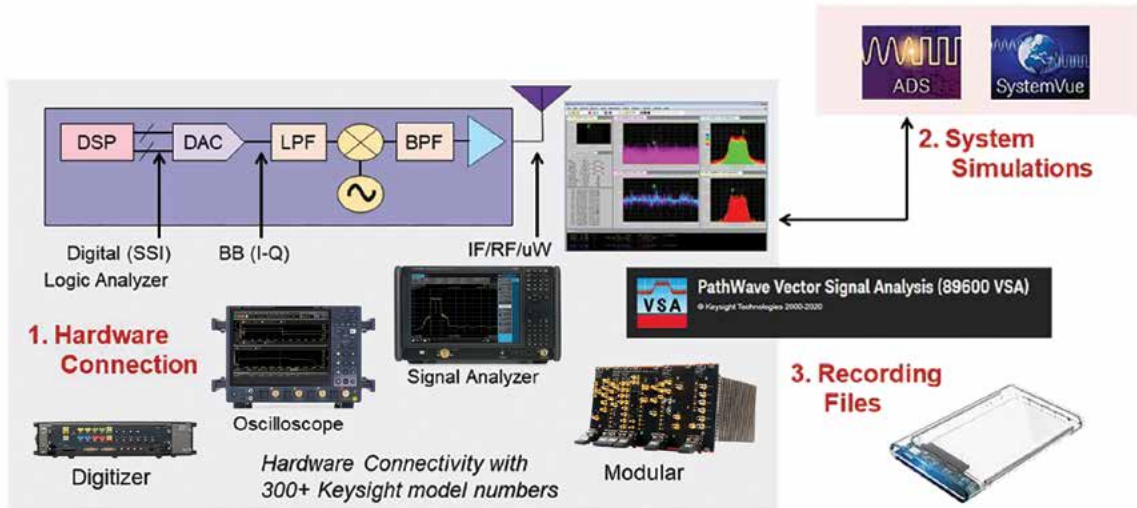

Figure 17.24. Hardware connectivity with 300+ models

A second option is through simulation results. The VSA software connects to both PathWave Circuit Design (formerly known as Keysight Advanced Design Systems) and PathWave System Level Design (formerly known as SystemVue). The third option is through recording files. Assuming the sample rate and center frequency are well-known, waveforms may be brought into the VSA that may have been saved to disk in Matlab format or various other binary formats.

Record Signals as IQ Waveforms or Pulse Descriptor Words for RF Playback

The VSA may be used to record long-time records as a way of monitoring trends or capturing unknown signals, irregular events or new threats yet to be understood.

A radar engineer can save measured RF data to an IQ data recording and then use that same data recording to play it back through a vector signal generator. The I and Q outputs from the data recording get played out as pulsed waveforms at RF frequencies.

With long-time recordings leading to many gigabytes of data, the radar industry invented this concept of Pulse Descriptor Words (PDW's), which allow an entire pulse to be submitted as a series of parameters describing that pulse. The most relevant characteristics like pulse width, PRI, and mean frequency are submitted as columns to a PDW file, where every row represents a different pulse. This PDW file may be then uploaded to an agile vector signal generator like the UXG.

Whether through an IQ data recording or using a PDW file, the recorded signal may be played into a radar receiver under test or radar jammer as a way of verifying its response or in EW parlance, verifying its

“techniques.” A radar analyst may thus capture signals from the sky or a test range and then submit that same captured signal to a radar receiver under test.

Characterize Individual Pulse and Pulse Train Similarity

An RF system engineer typically knows what the outbound pulses should look like. Their job is to generate accurate pulses and then look for impairments caused by the realities of the actual hardware. If they find a badly formed pulse, they will need to understand why and how to fix the component or subsystem responsible. On the other hand, a radar analyst typically collects large volumes of RF data on a test range and checks whether the overall system responded appropriately to an external threat. Typical questions might include: How long did it take for the emitter to change modes? Or, did the radar switch from search mode to track mode at the correct time? On the electronic battlefield, an adversarial signal may be trying to jam or confuse your radar receiver. To avoid this, the radar analyst maintains a catalog of pulse patterns as well as pulse characteristics identifying the equipment responsible. Measured pulses are thus compared against a catalog of known pulse trains and equipment signatures. To address the divergent requirements of both the RF system engineer and the radar analyst, the VSA provides two features - pulse scoring and pulse train search.

In both cases, we begin with the definition of some reference pulses. This is entered as a table with characteristics of amplitude, pulse width, pulse repetition interval, and average frequency. Whereas pulse scoring compares each corresponding pulse against the reference list of pulses, pulse train scoring evaluates the agreement of the entire measured pulse train. With pulse scoring, one may answer the question, “Is a pulse or series of pulses similar to a single reference pulse or series of reference pulses?” On the other hand, with pulse train scoring one may answer the question, “How do we know that pulses measured in a reference train happened in our latest measurement, and how closely do they match?” Certain figures of merit (like pulse width) may be emphasized more strongly than the others by way of base error tolerances. If the base error tolerances are set small, then that metric will play a stronger role in the overall score. Once the reference pulses and base error tolerances have been defined, measured pulses are color-coded both on the time trace as well as in the pulse summary table, as shown below.

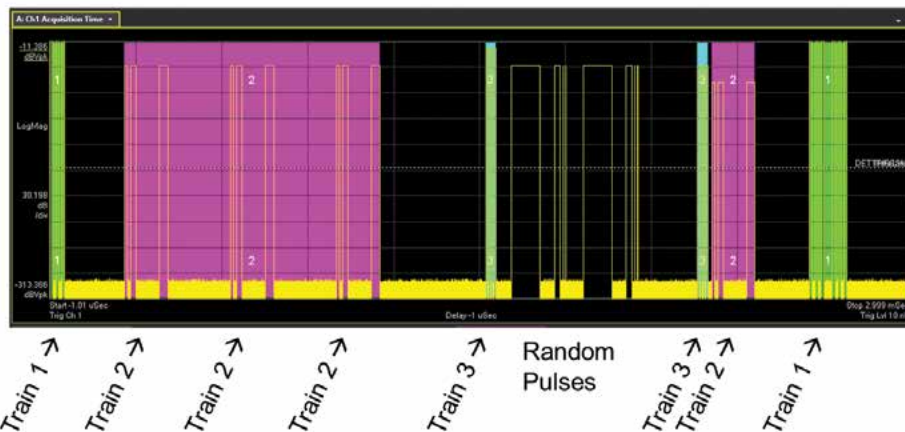

Figure 17.25. Pulse train

Fast-Time Slow-Time Display and Doppler Plots

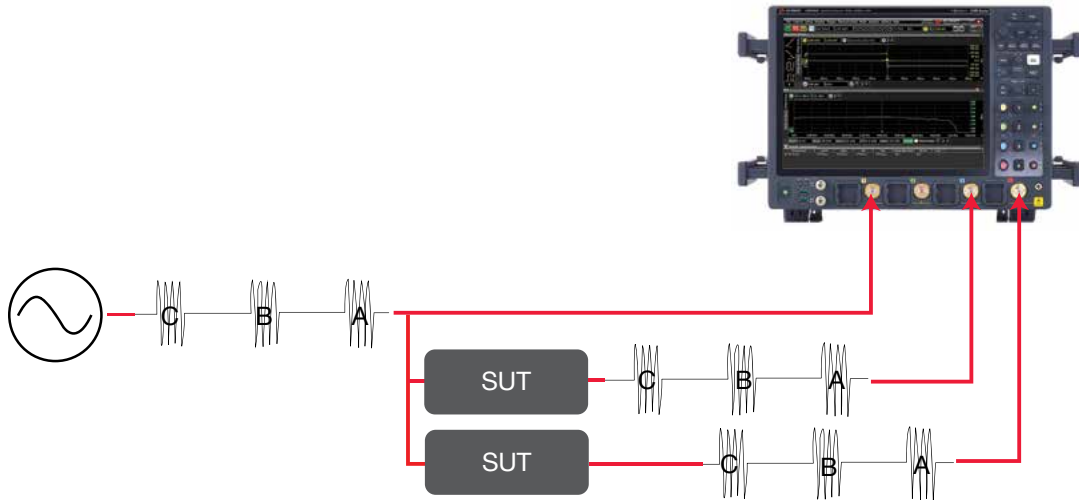

Figure 17.26. Input-to-output difference

A System Under Test (SUT) will receive a train of pulses and then in response, output a train of pulses. To characterize the efficacy of this response, it becomes necessary to chart the pulses at the input and the output of the SUT. A multichannel scope, like the UXR, may be used to collect phase-coherent time-domain data to look at channel-to-channel differences or more specifically, input to output differences. Based on the number of channels in the receiver, multiple SUT's may be tested in parallel.

Radar engineers often want to track the evolution of the SUT's response to an incoming pulse, so the pulse repetition interval demarcates a "fast-time" slice. In plotting the evolution of the SUT response across fast-time intervals, a new notion of time lends itself to the name "slow-time." Below, we show the incoming signal on channel 1 and SUT response on channel 2 in Time vs. Time Heatmap traces. This illustrates a classic "Range Gate Pull-off" technique.

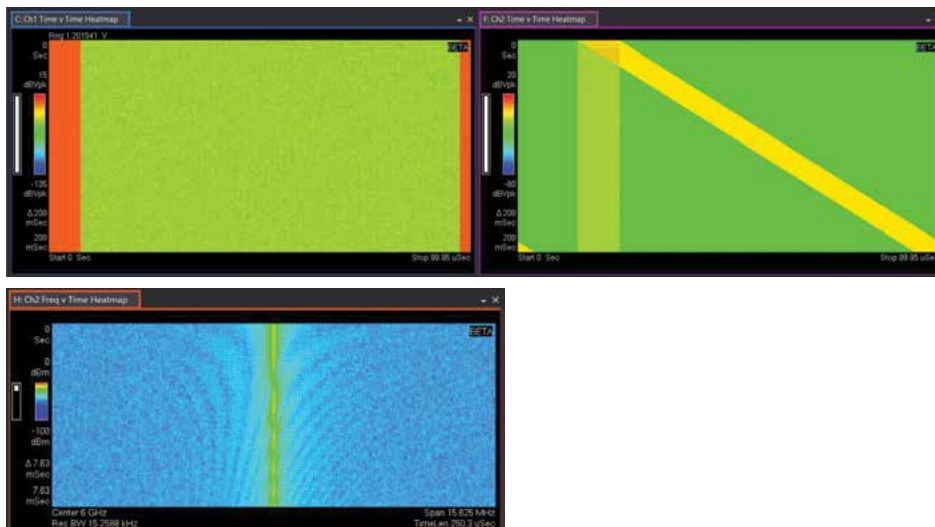
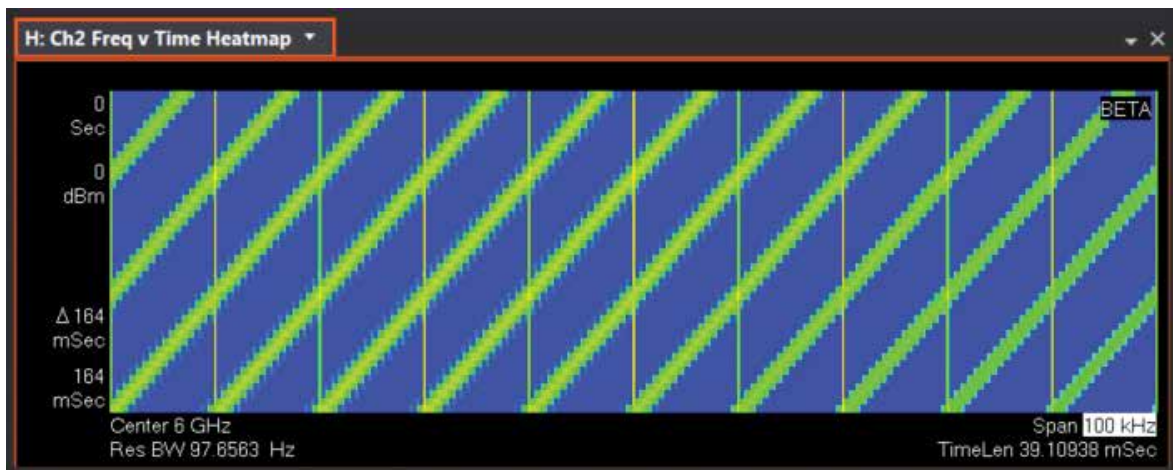

Figure 17.27. Freq vs Time heatmap

A frequency-domain representation of the output signal can reveal a Doppler shift as evidenced by slight frequency shifts in the SUT output signal. To capture time-domain data with high fidelity, a wide bandwidth is required. However, this wide bandwidth provides a macro view of the frequency spectrum, preventing a proper view of the frequency shifts due to the velocity change of the target.

The span needs to be narrowed significantly to support the most likely frequency shifts. After changing the span, VSA resamples the same data to show the changing frequency impulses versus time, with the most recent time slice displayed at the bottom.



This however results in a significant blurring of the details in the Time vs. Time Heatmap. So how can we achieve good resolution in the time-domain as well as in the frequency-domain? The multi-measurement capability in the VSA enables this, where the span for Meas01 may be set to 16 MHz for better Time vs. Time resolution and independently, the span for Meas02 may be set to 100 kHz for better Frequency vs. Time resolution. Both the Time vs. Time Heatmap and Frequency vs. Time Heatmap traces are offered in basic vector mode and pulse analysis mode.

Since the days of Nikola Tesla and other pioneers, radar has become ubiquitous and the breadth of its application is still growing. At the same time, radar technology has become more sophisticated as signal processing is commonly used to enhance the returned signal and to extract information, such as target images during post processing. However, no matter how sophisticated the signal processing becomes, the performance of every radar and EW system is directly determined by the quality of the underlying transmitters and receivers.

Understanding radar measurements and how instrumentation responds to radar signals is crucial to designing high-performance and cost-effective radar solutions. This chapter has sought to provide an explanation of common radar measurements and highlight the measurement solutions available today. Critical radar measurements include power, spectrum, pulse characteristics, antenna gain, target cross-section, component gains and losses, noise figure, and phase noise—all of which can be shown, through the radar range equation, to directly influence the performance of the radar. These measurements should always be made using quality test equipment designed to deal with the unique and demanding characteristics of radar systems and signals.

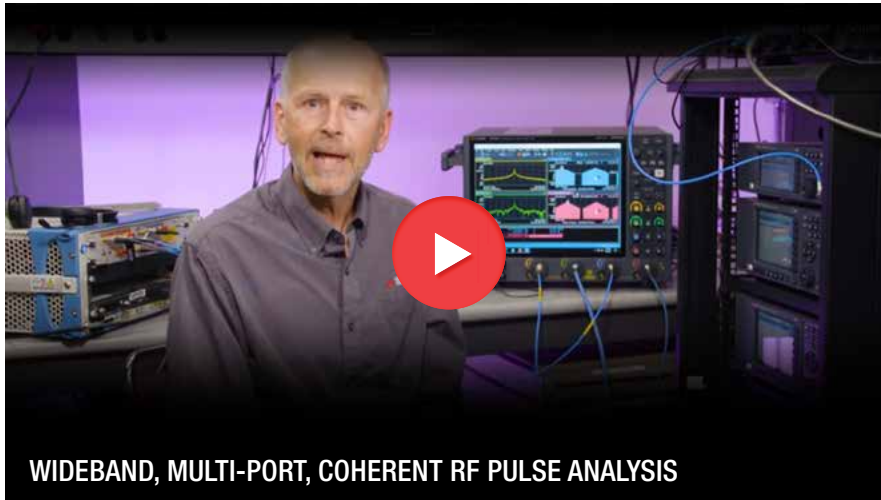

<https://www.keysight.com/see/radar-ew-subsystem-test>



Chapter 18 Testing TR Modules Efficiently

Radar, satellite, and electronic warfare (EW) systems utilize a wide variety of microwave modules. Active Electronically Steered Arrays (AESA) is one of the most critical and complex modules of a Synthetic Aperture Radar (SAR).

A phased array antenna with an array of antenna elements controls the relative amplitude and phase of signals from these elements to concentrate the energy in the desired direction. The attenuator and phase shifter in each TR module quickly change their states, which enables a phased array antenna to scan the narrow beam very rapidly.

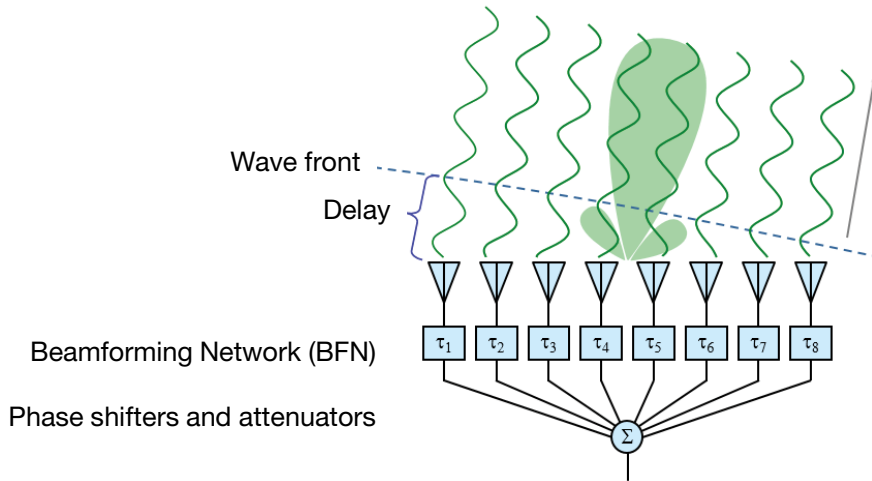

Figure 18.1. AESA beamforming network

Today's phased-array antennas utilize 100s or even 1000s of antenna elements with TR modules. Their energy can be directed and scanned to multiple positions, which makes them extremely flexible for use in radar, electric warfare, and communication applications.

Active electronically scanned arrays, or AESA antennas, are the latest version of the phase-array antenna. AESA can form a lot of antenna patterns. This provides versatility with a wider scan angle and multiple concentrated beams for detecting and tracking multiple targets simultaneously.

Precise relative phase and amplitude control are crucial to the AESA capabilities. Shown here is a typical AESA antenna with 24 test ports and 6-bit phase and 6-bit attenuator control. It has 4096 settings per test port and is tested at 21 frequency points. That is over 2 million antenna patterns to be tested, Figure 18.2.

4096 antenna patterns per frequency and test port

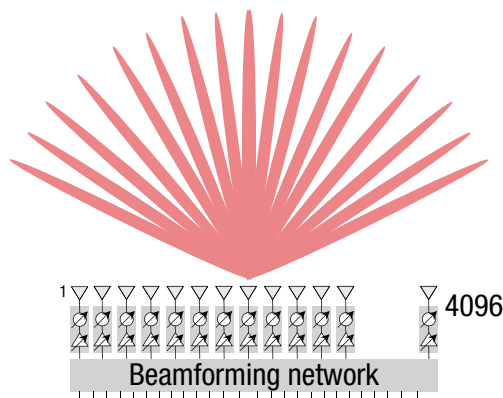

- Θ scan angle: $\pm 45^\circ$
- Φ scan angle: $\pm 45^\circ$
- 24 test ports
- 21 frequency points
- 4096 'beam' positions per port and frequency

$$24 \times 21 \times 4096 =$$

2 million antenna patterns!

Figure 18.2. AESA test

Table 18.1 shows three types of phased-array antenna systems with their typical applications and characteristics.

Type 1	Type 2	Type 3
Communications, weather radar, perimeter detection, imaging radars, automotive radars, etc.	Communication on ships, airborne intelligence, surveillance, reconnaissance (ISR) radars, etc.	Fire Control, EW, ECM, etc.
30 to 100 mW per element on Tx, can be done in SiGe + lowpower GaAs	Medium power, can be done in SiGe + medumpower GaAs	High-power, 3 to 10+W per element, GaN, maybe SiGe
\$	\$\$	\$\$\$\$\$

Table 18.1. AESA-applications and characteristics.

Source: TRM tutorial session at IEEE International Symposium on Phased Array Systems & Technology; October 17-21, 2016.

Type-1 RADARs are low power and low-cost arrays for communications, weather radars, perimeter detection, and automotive radars. The range of applications is rapidly growing. The phased-arrays needed for future 5G systems will be in this category. Type-2 RADARs are medium power phased-arrays used for military intelligence and surveillance which have a higher cost per element. This type of radar system is also growing rapidly as communication and situation awareness become more and more important. Type-3 RADARs are very high power per element and very expensive. These are used in applications for fire control radars, electronic warfare, and electronic countermeasures. GaN is the current semiconductor of choice for these high-power applications.

Applications for phased-array antennas are expanding and growing rapidly in aerospace and defense to commercial industries, with medium to low power but highly integrated form factor. TR modules typically need extensive testing to ensure that they are matched across the phased-array in which they are used.

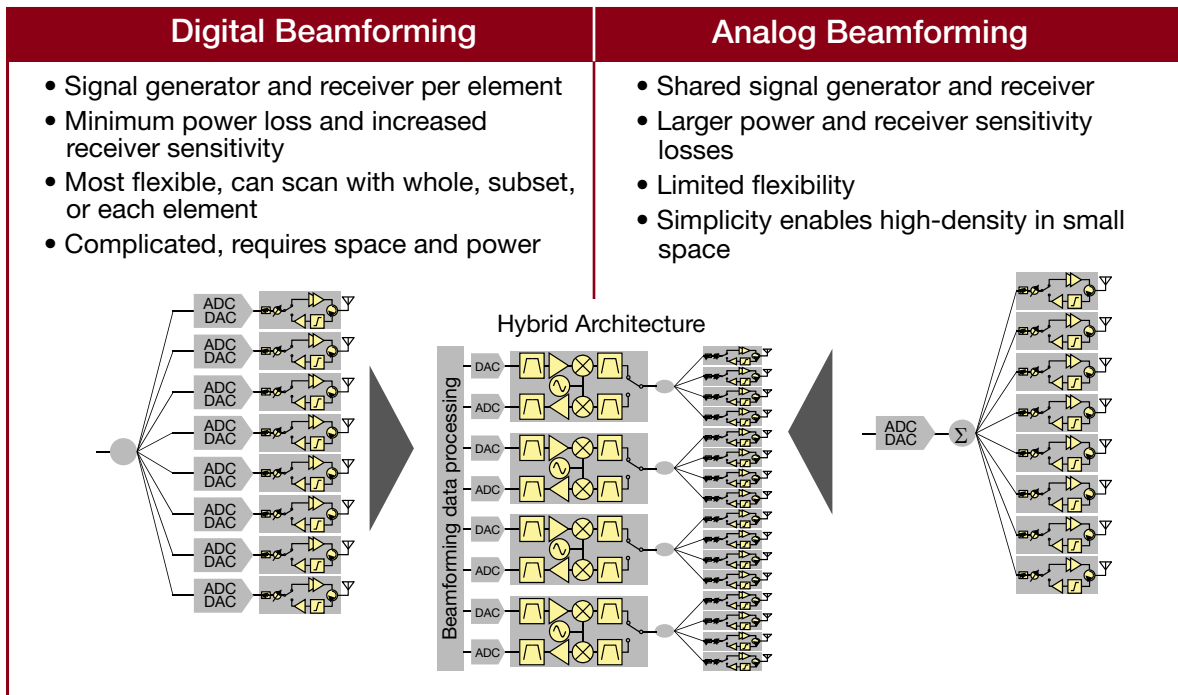

Table 19.2. Digital vs Analog beamforming

Digital beamforming in phased-array antennas is becoming popular in both military and commercial applications. It has a radar exciter, or signal generator and a receiver right behind each TR module, and provides the most flexible beam control. This configuration minimizes power loss in the transmitter and increases receiver sensitivity. The tradeoff is that it increases the complexity and requires more components and space than analog beamforming. An alternative approach is a combination of analog and digital beamforming to optimize special and power requirements, as well as performance and versatility requirements.

The active phased array allowed lower RF power per element in the front-end. Lighter and smaller structures became replacements for bulky waveguide manifolds. This enabled more elements in a system and allowed more sophisticated digital beamforming.

Then with the planar structure, the whole system became smaller, lighter, and cheaper, but required more components to be integrated into a smaller form factor.

Now, as function blocks like front-end TR modules, signal generators, and receivers baseband digital processors become available in IC chips and frequency range is extended; the phase array antenna systems will find applications in many industries. Then we begin to see needs of different scales and sizes, lower-cost structures, high-volume production, and maybe new performance requirements.

Ultimately, front and back-end RF and digital sections will be fully integrated and attached directly to the antenna array. It will drive full scalability in size, cost, power, frequency, and bandwidth making it easier to adapt to different requirements.

Trends and Challenges

TR modules have a major effect on RF performance. During transmit operations the output RF pulse is amplified by the module, thereby defining the maximum radiated power of the radar. Because the transmitter is operated in pulsed mode, output pulse parameters are typically measured. During receive operations, the low-noise amplifier (LNA) within the module input determines the system noise figure and consequently the minimum detectable signal. Within each path, programmable phase shifters and attenuators control the antenna beam-steering and determine the angular accuracy of the radar.

Now, let's review the front-end TR module and its trend.

Here we see a typical TR module. In one direction it's a pulsed power amplifier, in the other, it's a low noise amplifier. All the RF characteristics of these paths are dominated by these devices and circuit designs around them.

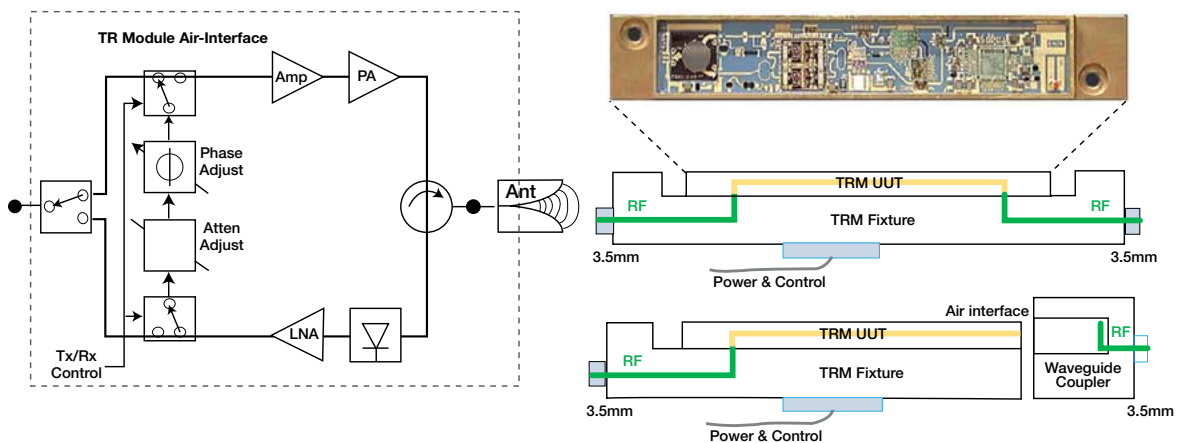

Figure 18.3. TR module

The unique part of a TR module is the phase shifter and attenuation adjusters which allow each TR module to have its own settings. The attenuator and phase states can be re-programmed for each radar pulse.

When TR modules are tested, they are attached to a fixture with a coaxial interface or waveguide adapter for modules with built-in antennas. Then, the fixtures are de-embedded from the measurement results.

Let's now focus on TR modules most commonly used today and discuss their test requirements and challenges.

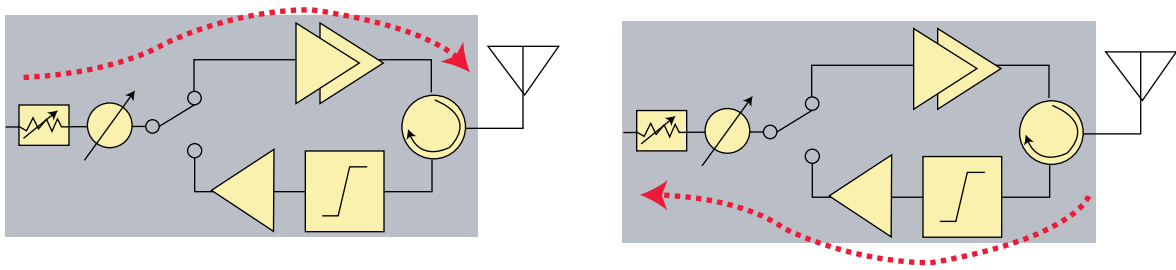

Figure 18.4. TRM transmit and receive path

Let's start with the transmit path (Figure 18.4). The signal in the transmit path is typically pulse-modulated. It goes through an attenuator and a phase shifter, and then a power amplifier. To deliver amplitude- and phase-controlled signals to the antenna element, the input and output matches of the path, gain, and attenuation and phase offset deviations are measured at every possible setting over the operating frequency range. The attenuation step can be 0.5 or 1 dB in the 20 to 30 dB range, and the phase offset is controlled in about 3-degree steps or less from -180 to +180 degrees. The number of combinations, in this case, varies from a few to several thousand. Each set of measurements are simple S-parameters, but there are a lot of amplitude and phase states to be tested.

Furthermore, the power amplifier characteristics are tested. This includes a 1 dB compression point or P1dB, maximum output power at P1dB or at saturation, 2nd and 3rd harmonic distortions, and output-referred IP3. It is quite simple to measure the gain, then find P1dB and the output power with a vector network analyzer. Notice they are all tested versus frequency. If it is tested at every 10 MHz in the whole X-band, the measurements have to be repeated 401 times.

Distortions are traditionally tested with signal generators with a combiner and a spectrum analyzer. This approach is simple to implement and very straight-forward for fixed-input frequency, but it is time-consuming for testing versus frequency.

Now, let's look at the receive path. The receive path has a power limiter at the front-end to protect the following low-noise amplifier from unexpected high-power signals. The phase shifter and attenuator are controlled in the same manner as the transmit path. The matches and gain are tested over the operating frequency and the various attenuator settings. They are simple measurements but require a lot of steps.

The input path is the front-end of the whole receiver chain where distortions are tested. They include 2nd and 3rd harmonics, input-IP2 and IP3 or IIP2 and IIP3. They are calculated with the main output power, 2nd- and 3rd-order IMD, and the gain. A spectrum analyzer is used for distortion measurements, and a VNA measures the gain. Testing IIP2 and IIP3 requires data from both instruments and some math. They are also tested versus frequency, so it becomes even more complex.

This is probably not common in production, but TR modules may be tested with transmitter and receiver subsystems in design characterization. The matches stay simple as S11 and S22, but transmissions become conversion gains between the input and the output at different frequencies. Amplitude

measurements are relatively simple, although calibrations require extra steps. Phase measurements need a slightly different measurement and calibration technique.

As there are frequency converters in the paths, there are more opportunities for signals leaking through undesired paths. High-order mixing products are generated so there are more spurs. The mismatches in the paths also make the signal flow more complex. These spurs and leakages must be tested in transceiver subsystems. Additionally, wideband performance with modulated signals may be tested, such as noise-power ratio, transmitter noise density, and receiver error vector magnitude. Vector signal generators and signal analyzers may be used for testing these performances. They may not be needed in a TR module test system, but it is better to be able to incorporate these additional capabilities when needed.

TRM Test System

Having understood the trends and TRM measurement challenges, let's understand considerations for building TR module test systems for higher test throughput and better test quality.

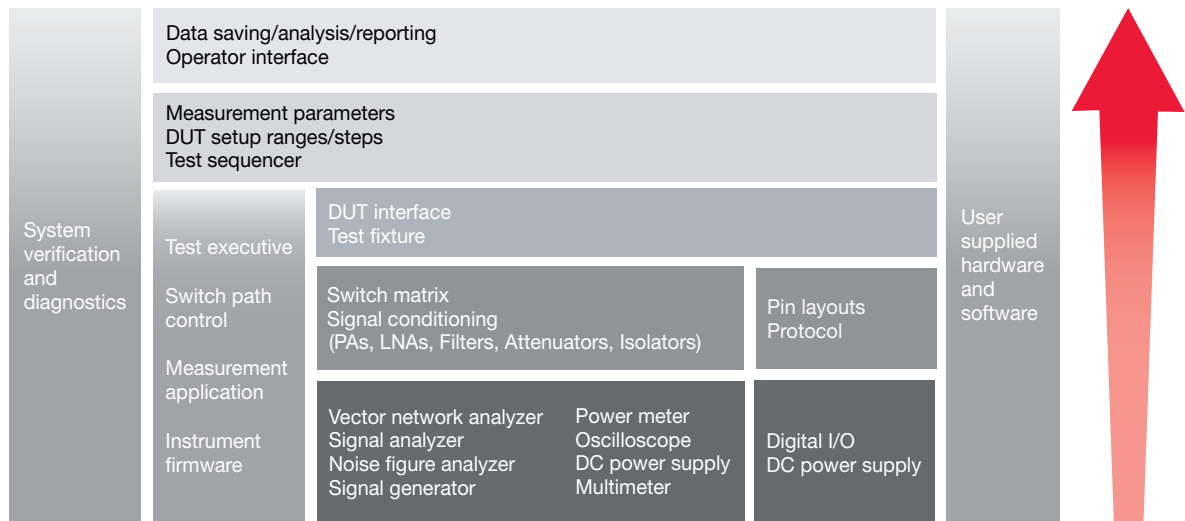

Figure 18.5. Conceptual building block for test system

Figure 18.5 shows a conceptual building block for test system integration. Building a test system involves three key areas of challenges viz. measurements, switch matrices and signal conditioning, and automation.

The measurement challenges are mostly addressed with tools and techniques that are available from instrument suppliers. Users need skills and knowledge to utilize them, but suppliers are typically able to assist.

The switch matrices and signal conditioning are unique to each test system and measurement requirement. It requires a good understanding of test specifications, RF and MW, and perhaps digital fundamentals. Suppliers for switches and signal conditioning devices will be able to identify the right products based on your requests, but you could spend a great amount of effort designing and optimizing the configuration.

Automation is a huge task. Controlling TR modules and sequencing the tests require a deep understanding of the module design, test plans, specifications, and expertise on hardware control and software integration. It also requires measurement knowledge to maintain the test quality so that the test systems perform as expected.

Before understanding the latest measurement techniques, let's review the traditional test approach.

Traditional test systems are configured with many instruments, each of which was designed for a specific set of measurements. For example, a power meter is used for output power measurements and a VNA is used solely for S-parameter measurements. Separate signal generators and spectrum analyzers are used for distortions and spurious tests. A noise figure analyzer is added for the NF measurements on the receive path.

Here is an example of a VNA with the latest hardware architecture (Figure 18.6). This is PNA-X with a 2-port configuration. It can have two internal sources with built-in harmonic filters with a signal combiner for two-tone IMD measurements.

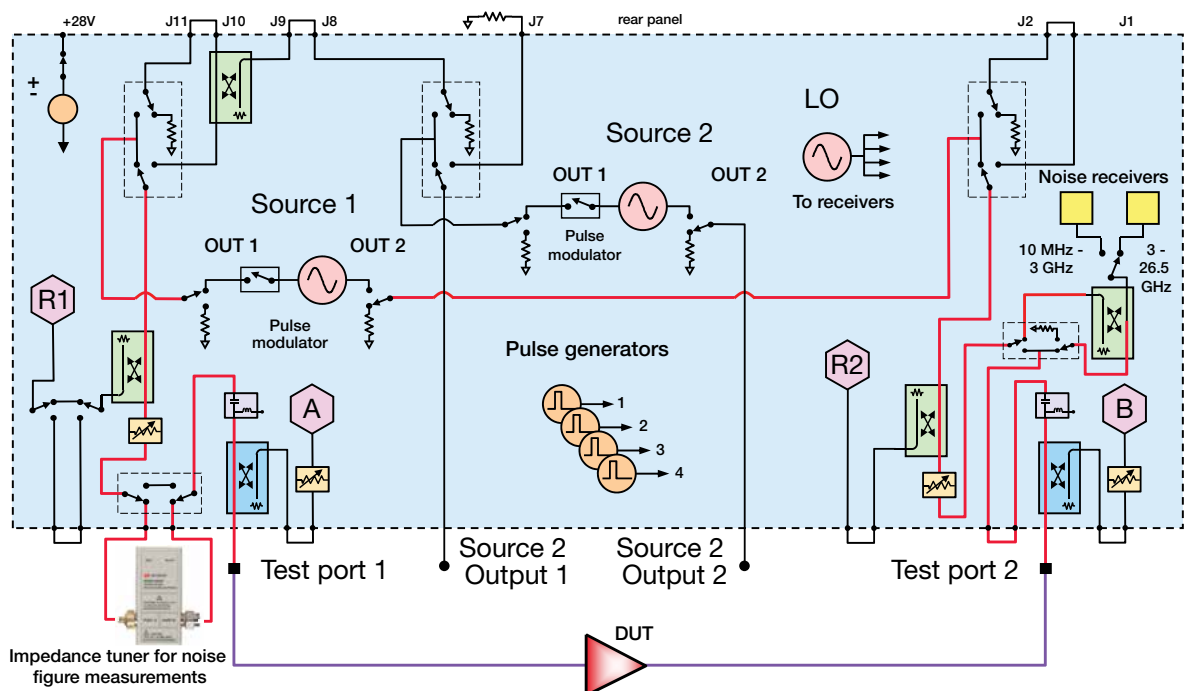

Figure 18.6. VNA architecture

The sources are capable of pulse modulation, controlled by internal pulse generators, which is useful for testing devices in radar applications. There are signal path switches behind the reflectometer so that signals are routed to different hardware for additional measurements while maintaining S-parameter measurement accuracy. Additional hardware may be included, such as a low-noise receiver for noise figure measurements.

The test fixture is connected to different instruments through a large multiplexing switch matrix, which adds large path loss and mismatches, causing drift and reducing system dynamic range. Software must control each instrument with a slow interface and longer instrument response time. This becomes a major problem for sequencing a lot of tests like TR modules.

These measurements are traditionally made with standard S-parameter measurements in a VNA. The compression, or P1dB, is found in swept power S21 measurements then the output power can be found at the same output power as the P1dB. It needs many setups to cover the required frequency range which causes throughput and calibration challenges.

The latest VNA, like the PNA-X, offers a software option called Gain Compression Application or GCA. In a single setup, the GCA controls the stimulus frequency, power, linear gain, P1dB, and output power at P1dB versus frequency with fewer measurement points. Using the GCA, the setup and calibration are simpler and the measurement speed is significantly faster than the traditional swept-power S21 method.

Spurious tests are typically done using a spectrum analyzer with fixed-frequency input to the DUT. The input frequency is stepped to cover the frequency range. The search range becomes wider frequency and lower level making it time-consuming. Repeating these measurements at different input frequencies can lead to hours of testing.

The slow sweep speed is mostly due to the microwave preselector at the spectrum analyzer input in swept mode. Spectrum analyzers use it for measurements with the highest level of accuracy. The latest spectrum analyzers also have FFT mode for faster measurements, but it bypasses the pre-selector and loses accuracy.

Let's move on to IP2 and IP3 measurements. Today we have a simpler way with swept-IMD applications. The swept-IMD controls the two internal sources and switches to make two-tone IMD measurements. By simply setting the center frequency, tone-spacing, and the sweep range we can choose the test parameter from the pre-defined list. This is easier than setting up individual source frequencies, programming to sweep, finding peaks, and calculating parameters using the traditional method.

One of the most important parameters of the receive path is the noise figure, which is defined as signal-to-noise ratio degradation. The noise figure is traditionally measured with either a noise figure analyzer or a spectrum analyzer with a noise figure option using a technique called the Y-factor method. The Y-factor method calculates noise figures from noise power measurements at the DUT output with hot and cold noise source states at the DUT input. This is very popular and works well when the noise source is connected at the DUT input. However, it assumes the DUT input is terminated with 50-ohm and

calculates the noise figure. When configured with switch matrices in an ATE system, this is no longer true, and the noise figure is greatly affected by the input mismatch. This method is also very slow, which limits the number of frequency points in practical use.

The noise figure application on PNA-X uses an optional low-noise receiver or standard VNA receivers that minimize the need for switching between the noise figure and other measurements. With industry-unique source-mismatch error correction, it delivers superior accuracy, especially in an ATE environment. It calculates noise figure from the device gain and noise power at the DUT output with no signal at the DUT input, so it is called the “cold-source” method. This method enables typically 10 to 40 times faster measurement speed than the traditional Y-factor method, enabling a finer frequency resolution with a small impact on the test throughput.

While this chapter focuses on the PNA series VNA for the TRM test, a similar but slightly modified approach can also be used with Keysight modular PXIe VNAs and latest the E5080B ENA for TR module testing.

Classic ATE systems are configured with front-end switch matrices to connect multiple instruments to a DUT. The design is simple, and it is easy to understand, but it is large, difficult to configure, less accurate, and very slow.

The ATE systems with the latest approach introduce more software capabilities and utilize front-end receivers for multiple measurements. However, not all required measurements can be done with a single type of receiver using software. You may need a signal generator for higher output power or complex modulation or a signal analyzer for wideband demodulation. Then you need to switch the paths to these instruments. And you would most likely need signal conditioning for some measurements and switch them in and out when changing measurement types. The best solution is to keep the front-end receivers as close as possible to the DUT interface so you can minimize the path loss and system drift. This is not always possible, but it is a good practice to optimize the path switches and maintain higher accuracy.

These signal conditioning devices often need to be switched in and out to optimize the performance of each measurement. A high-power setup for the transmit path is completely different from the one for noise figure tests on the receive path. We discussed earlier that switching should be minimized between DUTs and receivers, but there are many cases where you must switch them in front for better measurements, efficiency, or simplicity. If you can't avoid the switches, they must be linear, very low loss, and a good match. For these reasons, electro-mechanical switches are commonly used. There are a few different types of switches with unique capabilities (Table 18.3).

Multiport switch	Bypass switch	Transfer switch
<ul style="list-style-type: none"> - One input 2 to 6 ports outputs - Used to switch multiple DUTs to one instrument, or multiple instruments to one DUT 	<ul style="list-style-type: none"> - Configured with a pair of 1x2 switches - Alternate signal paths <ul style="list-style-type: none"> • Switch in/out a PA/isolator at the DUT input • Switch LNA and attenuator path for a receiver 	<ul style="list-style-type: none"> - Configured with a pair of 1x2 switches - Switch to opposite states to <ul style="list-style-type: none"> • Switch between 2 inputs and 2 outputs • Used for signal reversal • Configure as SPDT or bypass switch 

Table 18.3. Building switch matrices for signal routing

The first type of switch is a multiport switch. It has one input and typically from 2 to 6 output ports and is used to expand the number of test ports for multiple DUTs, to route a signal generator to multiple outputs, or sharing a signal analyzer with multiple input ports.

The second type of switch is a bypass switch. It is configured with a pair of one-by-two switches and used for switching a signal path from one to another. For example, it is used to switch in and out a booster amplifier and an isolator pair at the DUT input or used in front of a receiver and switches between a high-sensitivity path with an LNA and a high-power path with an attenuator.

The third type of switch is a transfer switch. It is also configured with a pair of one-by-two switches, but they switch to opposite states to switch between two inputs and two outputs and reverse the signal direction. It can be configured as a single-pole, double-throw, or bypass switch. It is often used as a bypass switch and for reversing the DUT connections between transmit and receive paths to simplify the test system configuration.

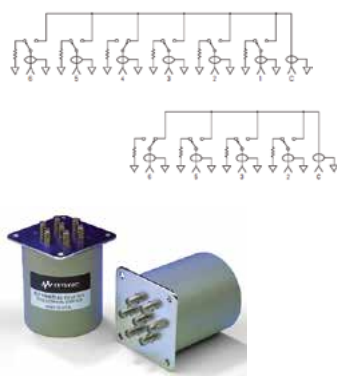
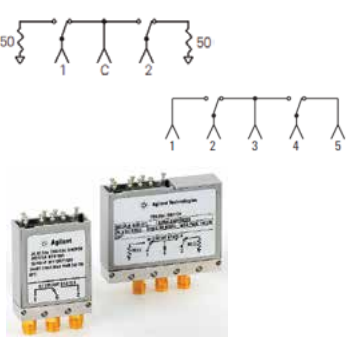
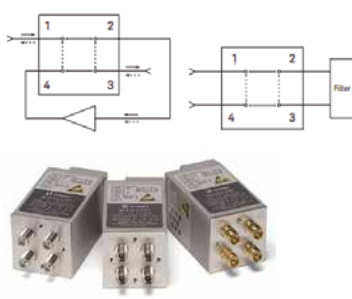
Once you have designed and built a test system with switch matrices, the next challenge is to design a calibration procedure that maintains the system's accuracy and minimizes user effort and errors. One approach is to integrate high-performance switches and calibration standards, such as an ECal module, a power sensor, and perhaps a noise source and a thru path. This can be expanded to multiport DUT topology with multiport switches. All paths from calibration standards to the reference planes are measured and stored as user characterization files in the ECal module and the PNA. This approach simplifies the calibration procedure and minimizes operator errors.

TR Modules need to be tested under environmental conditions. Under long temperature cycle for radar and EW applications and TVAC conditions for satellite applications.

Shown in Figure 18.7 is a configuration example with CalPods for measuring TR modules in a thermal vacuum chamber.

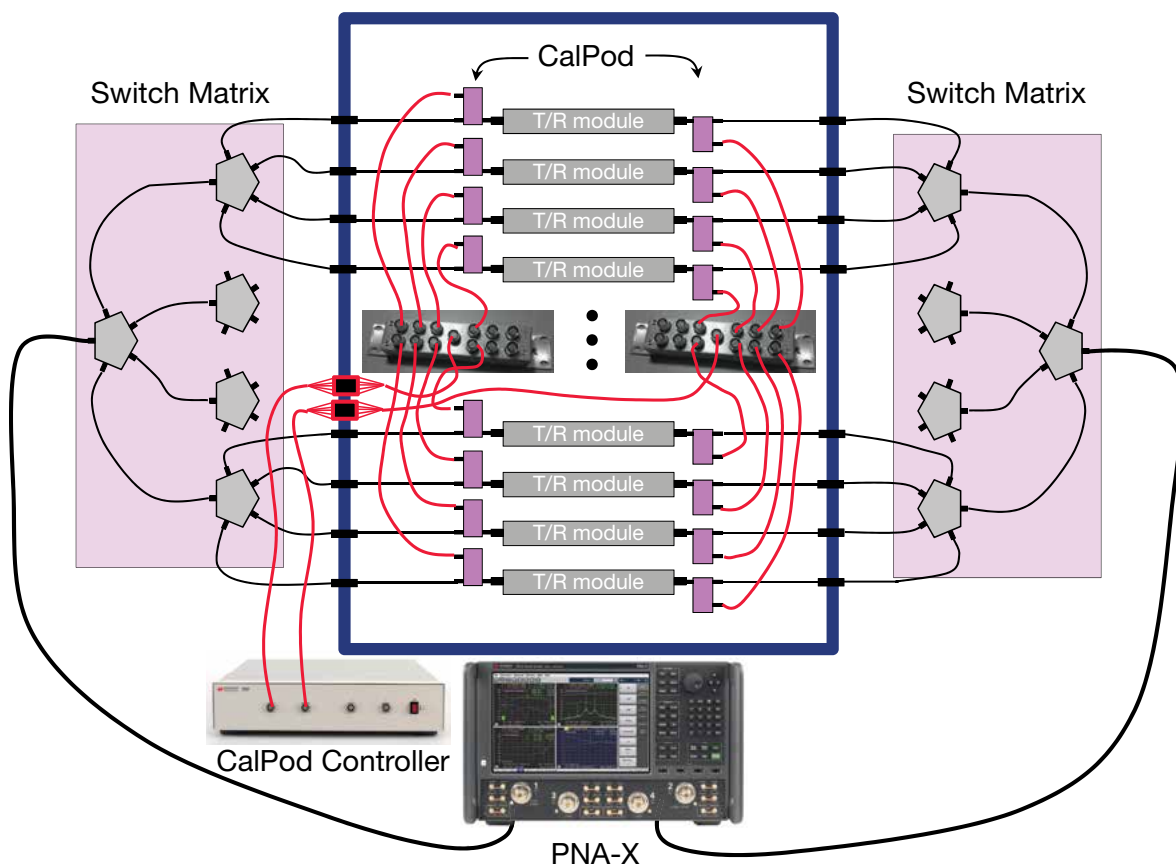

Figure 18.7. Calpod for maintaining measurement accuracy

The CalPod assemblies include multiple impedance states that are characterized over temperature range. They are left in-line during the calibration and measurements and allow re-correcting the drift or any path characteristic changes after the initial calibration. This approach increases calibration intervals, and saves a lot of operation cost, especially for testing devices in thermal vacuum chambers.

It is one of the most critical aspects of the TRM Test system to synchronize TR module attenuator and phase shift and getting the TR module state to change at every pulse of the radar's PRF. You can see the trigger handshake interactions between the PNA-X and the DUT control FPGA.

The PNA-X provides very flexible and low-latency triggering interfaces with DUT control FPGA, as well as other instruments in the system.

The DUT control FPGA manages the timing of measurements, detects the measurement completions, and attenuator and phase shifter states of the TR module over the proprietary interface.

Keysight's Pathwave Test Automation Platform is a Microsoft .NET-based framework, designed for speed and optimized execution. It provides a graphical user interface, which allows the user to quickly construct test plans with highly repetitive tasks. Customizable modular plug-ins are available for test steps, instrument/DUT interfaces, and result storage.

Pathwave Test Automation connection manager helps easily control the DUT, PNA-X, and non-Keysight instruments, and a variety of measurements, including switch matrices. Pathwave Test Automation command-line interface enables integration with other manufacturing applications and allows for various levels of customization. There are many plug-in tools for visualization and analysis as well.

For TR module testing, Keysight provides a custom PNA-X driver which can be scaled to execute a unique set of measurements and be synchronized to the DUT control required for phase shift and amplitude validation. The results can be shown in test development mode or automatic test mode in graphical format. The timing analyzer shows each test duration and provides insight into where to optimize the test sequence for the maximum throughput.

Pathwave test automation plug-ins can be used to export the data into a graphical or numerical format for easy analysis, test reports, and data archiving. The example here shows a graphical display on the test automation platform as PNA-X will display. All data can be saved with a variety of standard data formats.

Keysight Pathwave test automation is not just another programming language, it is a highly customizable and adaptable platform to speed up system integration for any skill level. It builds environments to archive plug-ins and re-uses them to make future system integration simpler and quicker.

Keysight leads the industry in the development of new and advanced measurement methodologies and techniques. TRM Automated Test solutions brings leadership experience to unique test needs and provides a standard configurable platform giving the ease of use and flexibility required to reduce TR Module test times without compromising measurement accuracy.



<https://www.keysight.com/see/radar-ew-subsystem-test>

Chapter 19

Understanding the Techniques for Antenna Testing

We work in a high-tech industry, where technology constantly changes and improves the way of doing things. To remain competitive in the radar and EW industry, we need to continuously evolve how we test antennas and RCS.

Before the mid-1980s, antenna and radar cross-section (RCS) test engineers used dedicated microwave receivers. In the mid-1980s, utilizing a network analyzer in an antenna or RCS application was a new and novel idea. Companies and individuals who adopted the new network analyzer technology to make antenna or RCS measurements were leading innovators, and many others came to follow this technology lead in later years.

With the next generation of network analyzers now available to the industry, the antenna test community needs to evaluate this new technology to see if it can provide similar gains in improved performance, accuracy, and speed to provide a better value for the antenna test community.



Antenna Test Parameters

Normally the antenna is tested under receive mode. However, certain applications require the antenna to be tested in transmit mode also. Numerous parameters exist for characterizing the performance of antennas and the most significant of these are discussed here.

- Antenna Impedance
- Radiation Pattern
- 3dB Beamwidth
- Directivity
- Antenna Gain
- Bandwidth

The antenna pattern is the response of the antenna to a plane wave incident from a given direction or the relative power density of the wave transmitted by the antenna in each direction. The antenna pattern can be realized by one of the three antenna pattern measurement techniques. The first technique developed was the far-field range, then near-field techniques, and compact range.

Near and Far-Field Regions

Let's understand the antenna radiating regions. It is divided into three regions:

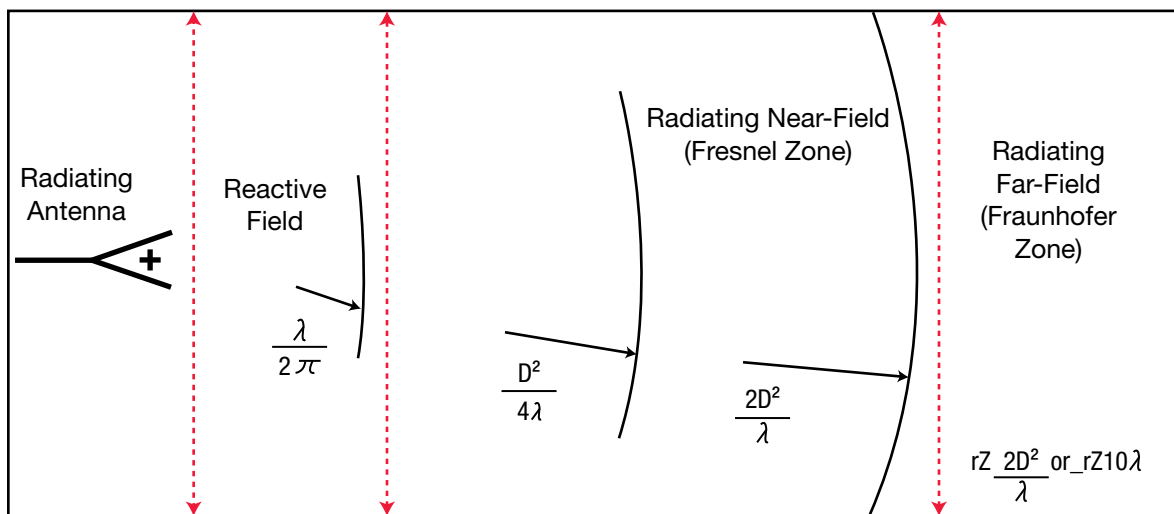

Figure 19.1. Antenna radiating regions

- 1. Reactive:** This region is the space immediately in front of the radiating portion of the antenna. The reactive region is from the surface of the antenna up to one wavelength away from the surface of the antenna. Successful measurements cannot be made in this region.

2. **Near-field:** Beyond the reactive region, is the near-field region. The near-field region is often thought of as existing from one to ten wavelengths from the aperture of the antenna. Because of geometric scan considerations, the near-field is usually sampled at one wavelength from the antenna aperture but can be sampled successfully at up to ten wavelengths.
3. **Far-field:** The transition from the near-field region to the far-field region is gradual, and not well defined. The far-field region has been historically defined as $2D^2/\lambda$. This distance provides for 22.5° of phase taper across the aperture (as defined by 'D') of the antenna. For low-performance antennas, this 22.5° of phase taper provided acceptable errors in the nulls and sidelobes of the antenna. However, the actual far-field distance that is required is more of a question of the amount of measurement error one is willing to accept in the null depths and sidelobes. When trying to accurately measure a very deep mono-pulse null or a very low sidelobe antenna, one may find that $10D^2/\lambda$ may be required to reach the far-field criteria necessary to achieve adequate measurement results.

The far-field range was the original antenna measurement technique and consists of placing the AUT a long distance away from the transmit antenna. The AUT is illuminated by a source antenna at a distance far enough to create a planar phase front over the electrical aperture of the AUT. The AUT moves Azimuth and Elevation directions when measuring the antenna pattern. The far-field technique can be implemented outdoors or indoors with a reflector (compact range).

Far-field antenna ranges were the original technique for characterizing antenna radiation patterns and have been in use for over 60 years. However, as the antennas have become larger and have increased performance, the far-field range distance has increased. Many factors have affected the viability of using longer far-field antenna ranges. Longer antenna ranges are subject to increased undesired reflections from the ground, buildings, and other man-made structures. Electromagnetic congestion has increased the interference from other sources, as well as the need to reduce electromagnetic interference from the antenna test range. All these factors have resulted in the need to find an alternative to far-field testing.

The first alternative to far-field testing is near-field testing, which is a technique that has been known for many years but did not come into popular acceptance until the availability of adequate computational power of computers. The near-field technique measures amplitude and phase data at half-wavelength intervals across the radiating aperture of an antenna and utilizes a two-dimensional Fourier transform to transform this measured near-field data to an equivalent far-field radiation pattern. Near-field techniques began to gain popularity about 20 years ago, as the computational power of PCs was able to handle the two-dimensional Fourier transforms. Today, near-field measurements are widely used by antenna test engineers because of their many benefits. They utilize smaller carbon footprints, are not as affected by electromagnetic interference, nor do they contribute to electromagnetic interference, provide all-weather testing capabilities, provide security for testing proprietary antennas, and the errors associated with near-field antenna ranges are much smaller and better characterized than for far-field antenna ranges.

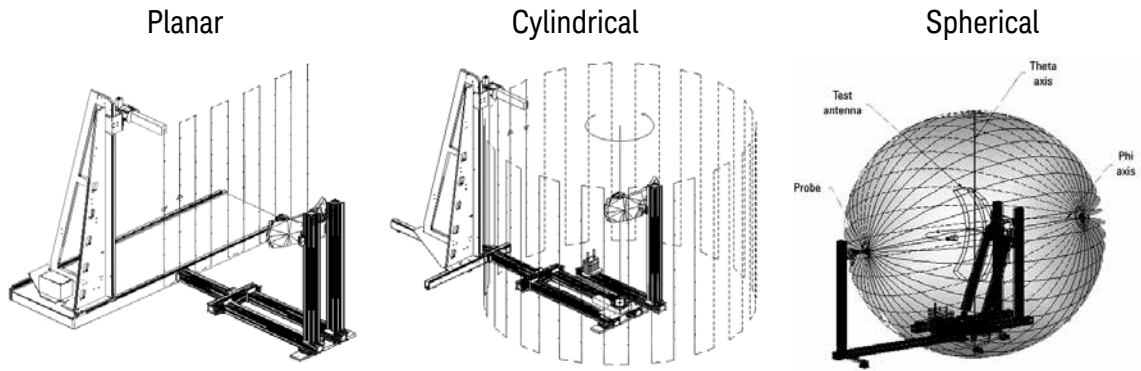

Figure 19.2. Scan type for near field antenna testing

There are three types of near-field scans:

- **Planar Near-field scanning:** The measurements are conducted by scanning a small probe antenna over a planar surface. These measurements are then transformed to the far-field by use of a Fourier transform.
- **Cylindrical Near field scanning:** It measures the electric field on a cylindrical surface close to the AUT. A Fourier transform using cylindrical coordinates is used to transform the measurements to the far-field.
- **Spherical Near-Field scanning:** It measures the electric field on a spherical surface close to the AUT. A Fourier transform using spherical coordinates is used to transform these measurements to the far-field.

The 2nd alternative to far-field testing is a compact range which is another type of far-field facility. These are typically located indoors, using anechoic material and large reflectors. Once the radiated energy passes the focal point of the reflector, the signal is in the far-field. Compact antenna chambers have a “quiet zone” that defines an area in which planar waves meet the far-field criteria.

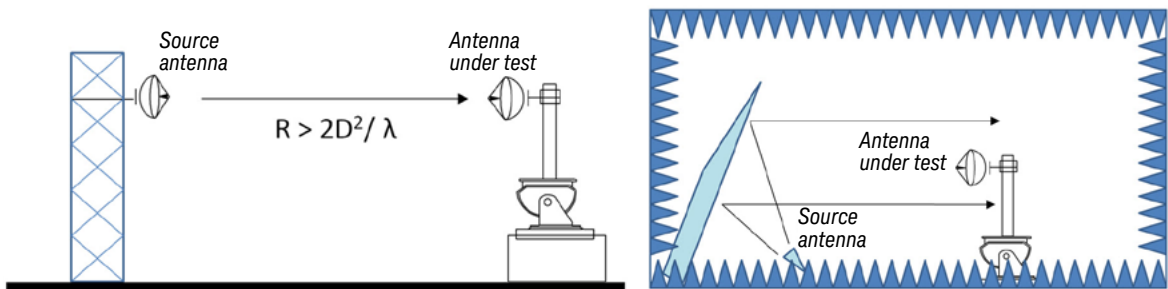

Figure 19.3. Far-field test facilities are outdoor and compact indoor

Antenna Measurement System

A typical antenna range measurement system can be divided into two separate parts: the transmit site and the receive site.

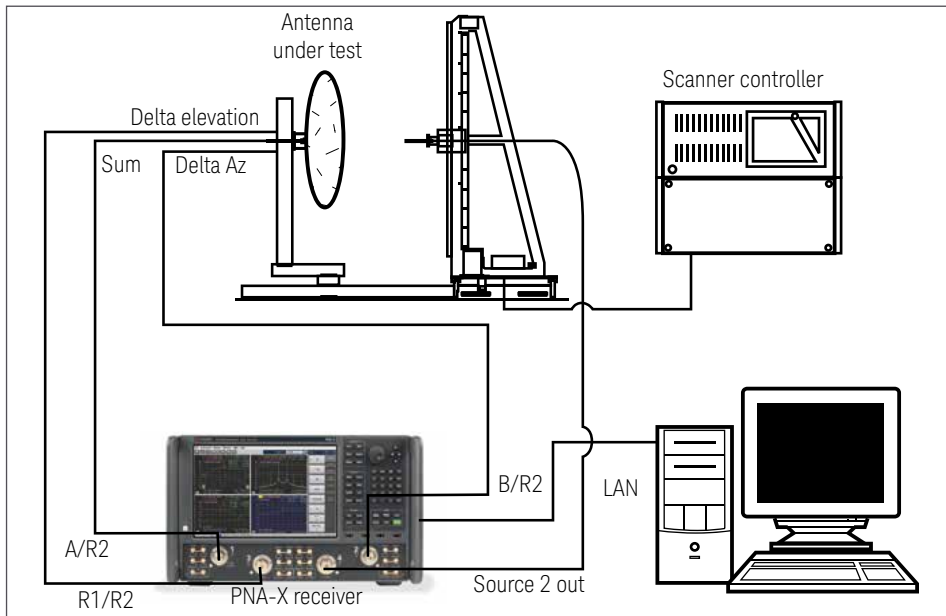

Figure 19.4. Typical near field test range

When designing an antenna test facility, many parameters must be considered to select the optimum equipment. Typically, one begins by considering the components for the transmit site, then moves to the receive site. Designing a complete antenna system often requires you to configure the transmit site, then the receive site, adjust the transmit site, and recalculate the values for optimum performance.

Transmit Site

The transmit site consists of the microwave transmit source, amplifiers (optional), the transmit antenna, and the communications link to the receive site.

In selecting the transmit source, consider the frequency range of the antenna under test (AUT), the distance to the transmit antenna, the available power of the source, and the speed requirements for the measurements. For compact and near-field ranges, the internal VNA source will typically be the best source to meet your measurement requirements. The internal source is faster than an external source and may lower the cost of the complete system by eliminating a source. Large outdoor ranges may require an external source that can be placed at a remote transmit site. Start by estimating the effective radiated power (EIRP) of the transmitter site. The effective radiated power is the power level at the output of the transmit antenna. To understand the required power level at the transmitter site, begin by making your power calculations. If after doing the power calculations the transmit power is not high enough, you may like to add an amplifier and run the calculations again.

Receive Site

The receive site consists of the AUT, a reference antenna, receiver, LO source, RF downconverter, positioner, system software, and a computer.

The free-space loss of an antenna range determines the difference in power levels between the output of the transmit antenna and the output of an isotropic (0dBi) antenna located at the receive site. The test channel received power level must be calculated to determine the approximate maximum power level present at the output of the antenna-under-test (AUT). The required measurement sensitivity is determined from the test channel received power level, the required dynamic range, and the required measurement accuracy.

$$P_D = 32.45 + 20 \cdot \log(R) + 20 \cdot \log(F)$$

Where:

R = Range length (meters)

F = Test frequency (GHz)

This equation does not account for atmospheric attenuation, which can be a significant factor in certain millimeter-wave frequency ranges.

$$P(\text{AUT}) = E_{\text{RP}} - P_D + G(\text{AUT})$$

Where:

E_{RP} = Effective Radiated Power (dBm)

P_D = Free-space loss (dB, at the maximum test frequency)

$G(\text{AUT})$ = Expected maximum gain of AUT (dBi)

Measurement accuracy is affected by the measurement sensitivity of the system. The signal-to-noise ratio will directly impact the measurement accuracy of the system for both amplitude and phase measurements. The frequency and sensitivity requirements of your antenna system will determine the network analyzer specifications.

$$\text{Sensitivity} = P(\text{AUT}) - \text{DR} - \text{S/N} - \text{L}$$

Where:

$P(\text{AUT})$ = Power at the output of the AUT (dBm)

DR = Required dynamic range (dB)

S/N = Signal-to-noise ratio (dB)

L = Cable loss (dB) from AUT to PNA input

Keysight has developed options for the PNA Series specifically for antenna measurements. Because of these options, the PNA Series is often the preferred analyzer for antenna solutions. However, some applications do not require these options and the lower-cost PNA-L Series or ENA Series analyzers may

be the right solution. For secure environments, a PNA or PNA-L Series analyzer must be used. Select an analyzer from the following table that meets your frequency and sensitivity requirements.

The VNA should be located as closely as possible to AUT to minimize the RF cable lengths. The measurement sensitivity of the PNA must be degraded by the insertion loss of the RF cable(s) to determine system measurement sensitivity.

If the AUT is located far from the analyzer, requiring long cables, then the loss caused by the cables could be significant, reducing accuracy and dynamic range. You may also be unable to find an analyzer that meets your sensitivity requirements. In this situation, down-converting the signal to an IF signal by using the LO/IF distribution unit with remote mixers brings the measurement closer to the AUT. This reduces RF cable loss and maximizes accuracy and dynamic range.

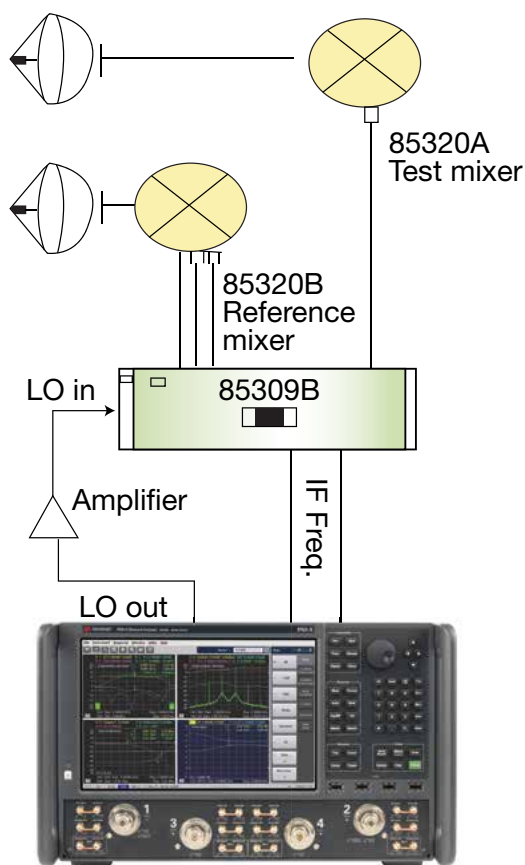

Figure 19.5. Remote mixing receive site

Measuring system speed for antennas is one of the important aspects of an antenna measuring system. Some applications require the fastest speed a system can provide, others are concerned with the best dynamic range available. With the PNA Series network analyzer, users can adjust their setup according to their specific needs. The selectable bandwidth feature can be used to optimize the measurement speed vs. sensitivity tradeoff.

By selecting the widest bandwidth available (5 MHz for DSP-4, 15 MHz for DSP-5), the measurement speed is maximized. The PNA-X analyzer is mixer-based, with fundamental mixing to 26.5 GHz, providing a 24 dB increase in sensitivity and dynamic range over sampler-based analyzers. This more than makes up for the sensitivity reduction realized when the IF bandwidth of the PNA-X is opened to its maximum to maximize measurement speed. Therefore, the PNA-X can achieve faster data acquisition speeds with increased sensitivity in near-field applications over legacy configurations.

RCS Testing

From the radar range equation, RCS (σ) has a direct effect on the ability of a radar system to detect a specified target at a defined range. Although the cross-section of the target cannot be controlled, the objective in modeling RCS is to develop simulation tools capable of predicting the behavior of radar receivers in a realistic environment.

A target's RCS is a measure of its reflectivity in each direction, and there are three main contributors:

- **Specular scattering:** Localized scattering dependent on the surface material/texture and geometry
- **Diffraction scattering:** Incident signal scattering at target edges and discontinuities
- **Multiple bounces:** Reflections among target elements at offset angles

Improvements in technology have enabled a deeper understanding of how to minimize an object's reflected energy. As designers become more adept at minimizing σ for the smallest possible return, the received signals are very small. The level of the returned signal is also affected by the need to use large distances with large objects (e.g., full-sized aircraft or missiles) to ensure a planar wavefront.

Computing the IFFT on a finite-length sample produces a noteworthy artifact: It creates repetitions or "aliases" of the fundamental signal in time. These aliases can be minimized or eliminated through a process of testing to find an alias-free measurement span. The width of this span will depend partly on the number of data points the analyzer can measure and process. RCS measurements tend to be very wide frequency sweeps, ensuring the presence of band crossings. High-power pulses are often used in RCS measurements to overcome the high losses due to low device reflection and two-way transmission path loss. For this reason, receiver gating is often required in RCS measurements to avoid overloading the receiver during the transmission of the pulsed-RF signal.

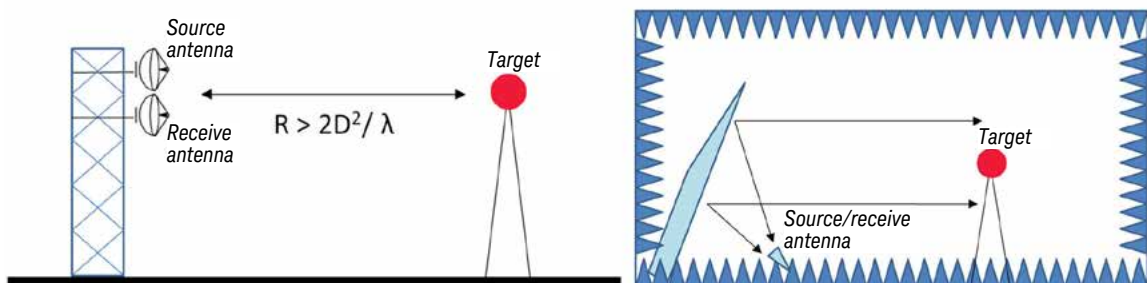

Figure 19.6. RCS test facilities: outdoor far-field and compact anechoic chambers

As with far-field testing, there are two main types of RCS facilities: a traditional outdoor test facility and the compact range (as shown in Figure 19.3). RCS testing tends to be sensitive from a security perspective, so outdoor test facilities are often in remote locations. Indoor test facilities offer optimum security but may become large and expensive depending on the size of the target.

Simplifying Test of Phased Array Antenna

Modern EW systems and radars use phase-array antennas. A phased-array antenna is a collection of antenna elements assembled such that the radiation pattern of each element combines with neighboring antennas to form an effective radiation pattern called the main lobe. The antenna array is designed to maximize the energy radiated in the main lobe while reducing the energy radiated in the side lobes to an acceptable level. The direction of radiation can be manipulated by changing the phase of the signal fed into each antenna element, which has an independent phase and amplitude.

The original way to implement a phased-array antenna is to use separate attenuators, phase shifters, and other components. With the new modular approach, each antenna element and its related transmit power amplifier (PA), receive low-noise amplifier (LNA), shifters, attenuators, and switches are packaged together in a transmit/receive (T/R) module.

In transmit mode, the signal from the transceiver passes through the attenuator, phase shifter, and T/R switch to the PA and then to the antenna. In receive mode, the signal from the antenna passes through the T/R switch to the LNA and the phase shifter and attenuator to the receiver section of the transceiver.

Requirements for test and measurement must align with the application challenges we just discussed. The testing of multiport DUTs presents four significant challenges:

- Efficiently testing all components in multiple-input/multiple-output (MIMO) antennas
- Improving measurement throughput and unit volumes while reducing cost
- Increasing the accuracy of testing for higher port-count devices
- Reducing the floor space needed for testing in component manufacturing

Various multiport measurement solutions are available today and we can divide them into two categories: switching solutions and true multiport VNAs.

Switching solutions include a two or four-port benchtop VNA and different types of switch matrices. Simple switching test sets are based on RF switches that route VNA ports to the various ports of the DUT. This type of multiport solution often uses a two-port VNA to reduce cost. These test sets are typically constructed from a combination of 1x2, 1x4, and 1x6 RF switches. Switching test sets do not offer measurements between any two ports, so care must be taken when designing the switch tree in the test set to ensure it meets the measurement requirements of the intended DUT.

Many multiport devices require measurements from each port to every other port. In general, the response of any path depends upon the loading or match applied to every other port. To obtain a full matrix of paths, a “full crossbar” switch matrix is required. In the general configuration, sets of 1xN switch trees are cross-connected to 1x2 switches at each port. This configuration allows any path to be measured and the unused ports are terminated with an internal load contained in the 1xN switches.

The switching-based approach has several drawbacks: complex setup, long test times, inadequate measurement performance, and trade-offs between time and cost.

Complexity in the setup

- Switch matrices might need additional software to assist with the measurements
- Implementation becomes more difficult as the number of ports increases
- Calibration of a full N-by-N system is difficult due to the need for port terminations

Very long test times

- Because many configurations share the source and receivers, test time becomes prohibitive
- Example: 24-port switching test set supports only 144 paths, but a 24-port device has 276 paths

Given these shortcomings, it becomes vital to understand a better way to address the test challenges. The solution is a new-generation modular VNA. It delivers three main benefits:

- Increased throughput and improved accuracy driven by enhanced speed and performance
- Enhanced configurability is well-suited to the requirements of integrated A/D subsystems
- Application versatility can satisfy the majority of the needs for the testing of A/D components

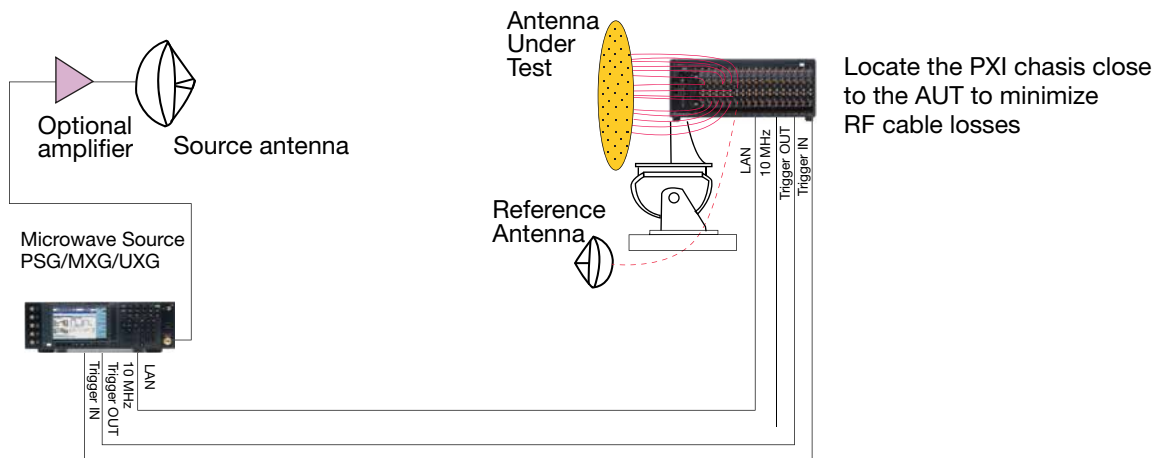

Figure 19.7. Far field multi-channel configuration

For multi-channel antenna measurements, a multi-channel vector network analyzer is becoming quite popular. Before the availability of multiport VNAs, an RF switch network was required to switch multiple antenna test ports into a four-port VNA. The switch network adds additional loss (reducing measurement sensitivity) and introduces additional measurement time to sequence through the various switch positions. With an M980xA multiport VNA, each output port of the antenna to be measured can be routed to an individual test receiver port, providing simultaneous measurements on every antenna port with each trigger from the antenna rotation positioning system. This significantly reduces the measurement time for a multiport antenna. With this multiport PXI VNA approach, there are no remote mixers utilized, so the RF signal is routed from the antenna directly to the input ports on the PXI VNA. Because of this, minimizing the RF cable length between the test antenna and the PXI VNA is important to minimize measurement sensitivity degradation. Some antenna ranges are being configured with the PXI chassis located as close as possible behind the antenna under test.

Further, to reduce the complexity of scanning a single probe antenna over a mechanical arch, multiple probe antennas can be mounted at fixed positions on an arch, and PIN switches were used to multiplex the different probe antennas into a four-port receiver. The AUT is then rotated slightly in azimuth and when the AUT has been rotated 180 degrees and the entire hemispherical radiated energy from the AUT has been measured, it's possible to do the computation of the antenna pattern.

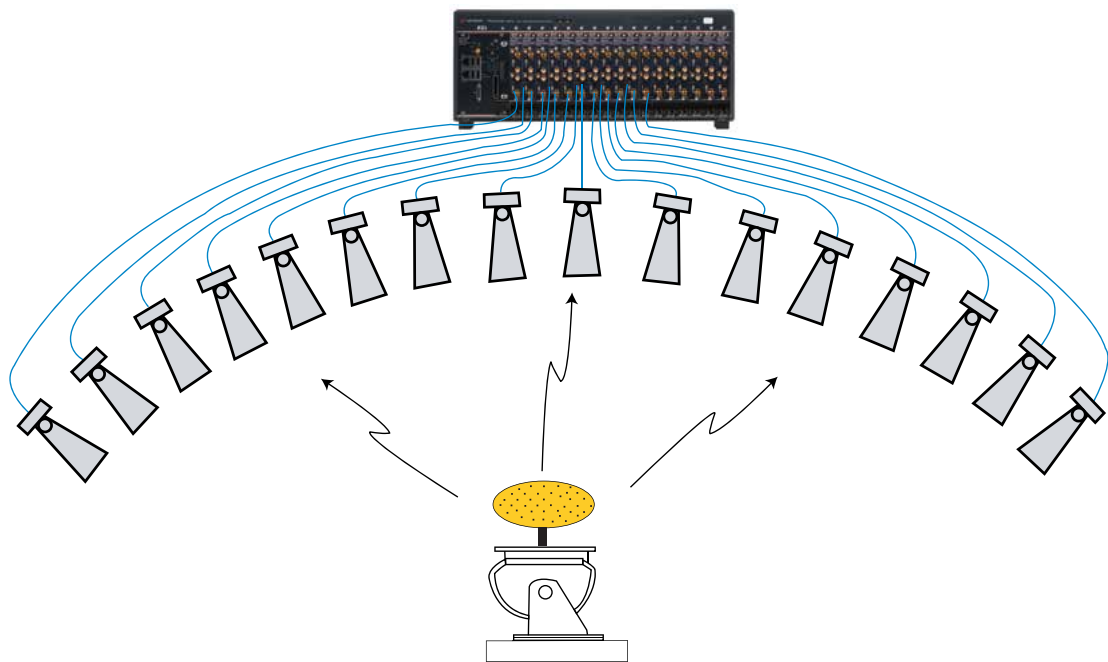

Figure 19.8. Measuring antenna patterns with multiport receivers

This method reduces the complexity of the mechanical positioning required for a single probe antenna but adds complexity and loss with the RF switches.

Keysight Technologies provides many of the components required to make accurate antenna and radar cross-section (RCS) measurements. Keysight instruments provide the greatest accuracy, reliability, and productivity available.

You can integrate our instruments into your antenna test systems to measure a wide range of data acquisition speeds and measurement sensitivities. Applications include near field, far field, and radar cross section measurements.

Section 5

System Level Radar and EW Test





Introduction

Today, different types of radar systems are used in a variety of applications: avionic, military, automotive, law enforcement, astronomy, mapping, weather, and more. Within this broad range of uses, several radar technologies have emerged to meet specific needs in terms of performance, cost, size, and capability. For example, many police radars use continuous-wave (CW) radar to simply assess Doppler shifts from moving cars; range information is not needed. As a result, low cost and small size are more important than advanced capabilities and features.

In this section, learn how to simulate an effective and accurate radar environment, and understand how these processes are innovative in the radar and EW industry. Various system level test and measurement procedures are covered including validation of jammers effectiveness, Electronic Intelligence, signal recording and analysis. The section highlights the critical need of system calibration, field testing, sustainment and services. It also touches upon the importance of software testing and new age cyber security.

Chapter 20

Avoiding 5G Coexistence and Effectively Simulating Background Signals

With new bands specified for 5G communications systems, there is now an issue of coexistence, which is radar and satellite using the same or similar frequency bands with 5G. Such coexistence can cause loss of capacity in 5G systems and can even damage sensitive front ends in satellite ground stations.



There are three primary use cases envisioned for 5G communication systems.

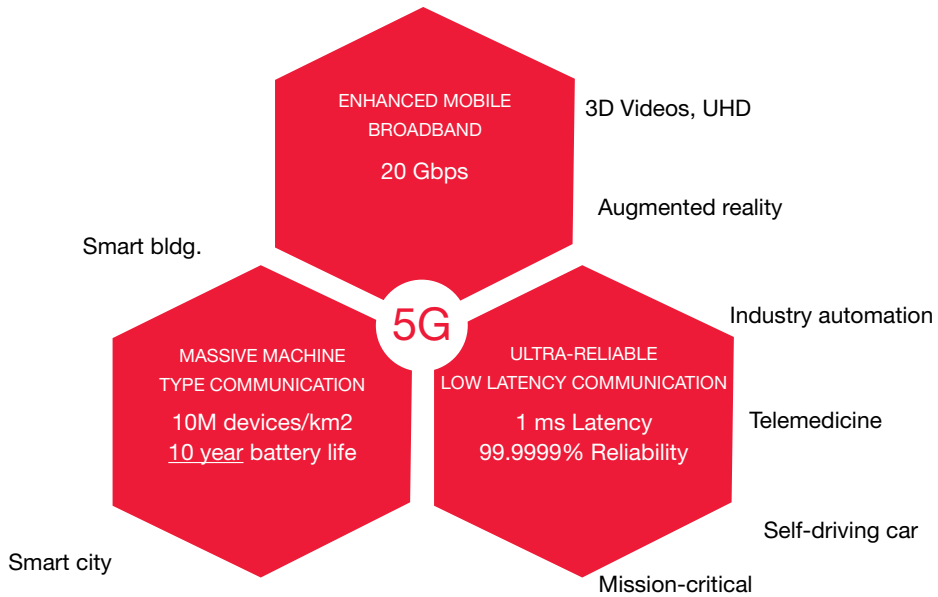

Figure 20.1. 5G use cases

The topmost hexagon is the familiar use case of watching high-definition videos on your phone. This could entail 3D videos or augmented reality. The lower right hexagon use case is ultra-reliable low latency communications. This would entail 1ms latency, roughly a 10x improvement, and 99.9999% reliability. Some of the applications include industrial automation, telesurgery, self-driving vehicles, and mission-critical communications. The lower left hexagon is massive machine-type communication. This is akin to IoT sensors, where you have 10 million sensors per square kilometer. The data that they pass back is meant to be low rate, therefore low bandwidth, and less power consuming. The battery in these devices is meant to last for 10 years, and after this time, the sensors are thrown away.

These 3 use cases signify different frequency bands. The enhanced mobile broadband service needs higher bandwidth, and higher bandwidth means higher frequency which tends to be 20+ GHz or higher. The ultra-reliable low latency communications require mid-band frequencies, roughly 3 to 6 GHz. The massive machine-type communications need low bandwidth to conserve power, so the frequency band tends to be < 3 GHz.

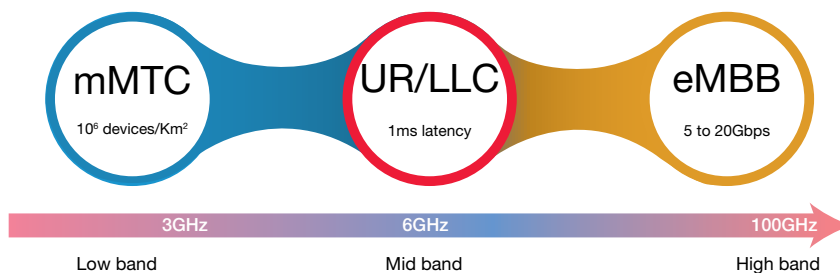

Figure 20.2. 5G NR spectrum targets for different use cases

5G operating bands are described by Frequency Range 1 and Frequency Range 2 (FR1 and FR2). Frequency Range 1 is also called sub-6 GHz, and incorporates the low-band and mid-band. FR2 includes bands around 28 GHz and 39 GHz and is also called mmWave. More bands will be allocated as 5G gets further revisions to the standard.

	Low Bands < 1 GHz (Freq Uplink, Freq Downlink unless otherwise noted)	Mid Bands 1 GHz - 6 GHz (Freq Uplink, Freq Downlink unless otherwise noted)	High Bands > w24 GHz (Freq Uplink, Freq Downlink unless otherwise noted)	
5G NR	n5: 824 - 849 MHz, 869 - 894 MHz n8: 880 - 915 MHz, 925 - 960 MHz n12: 699 - 716 MHz, 729 - 746 MHz n20: 832 - 862 MHz, 791 - 821 MHz n28: 703 - 748 MHz, 758 - 803 MHz n71: 663 - 698 MHz, 617 - 652 MHz n81: 880 - 915 MHz (SUL) n82: 832 - 862 MHz (SUL) n83: 703 - 748 MHz (SUL)	n1: 1920 - 1980 MHz, 2110 - 2170 MHz n2: 1850 - 1910 MHz, 1930 - 1990 MHz n3: 1710 - 1785 MHz, 1805 - 1880 MHz n7: 2500 - 2570 MHz, 2620 - 2690 MHz n25: 1850 - 1915 MHz, 1930 - 1995 MHz n34: 2010 - 2025 MHz, 2010 - 2025 MHz n38: 2570 - 2620 MHz, 2570 - 2620 MHz n39: 1880 - 1920 MHz, 1880 - 1920 MHz n40: 2300 - 2400 MHz, 2300 - 2400 MHz n41: 2496 - 2690 MHz, 2496 - 2690 MHz n50: 1432 - 1517 MHz, 1432 - 1517 MHz n51: 1427 - 1432 MHz, 1427 - 1437 MHz	n66: 1710 - 1780 MHz, 2110 - 2200 MHz n70: 1695 - 1710 MHz, 1995 - 2020 MHz n74: 1427 - 1470 MHz, 1475 - 1518 MHz n75: 1432 - 1517 MHz (DL) n76: 1427 - 1432 MHz (DL) n77: 3300 - 4200 MHz, 3300 - 4200 MHz n78: 3300 - 3800 MHz, 3300 - 3800 MHz n79: 4400 - 5000 MHz, 4400 - 5000 MHz n80: 1710 - 1785 MHz (SUL) n84: 1920 - 1980 MHz (SUL) n86: 1710 - 1780 MHz (SUL)	n257: 26500 - 29500 MHz, 26500 - 29500 MHz n258: 24250 - 27500 MHz, 24250 - 27500 MHz n260: 37000 - 40000 MHz, 37000 - 40000 MHz n261: 27500 - 28350 MHz, 27500 - 28350 MHz

Figure 20.3. Sub-6GHz and mmWave operating bands in 5G NR

There are many new operating bands in 5G. In particular, the n77 band spans 3.3 to 4.2 GHz and n78 band spans 3.3 to 3.8 GHz. Many new 5G commercial deployments are focused on these bands. This overlaps with a possible downlink frequency range of satellite ground stations, from 3.4 to 4.2 GHz.

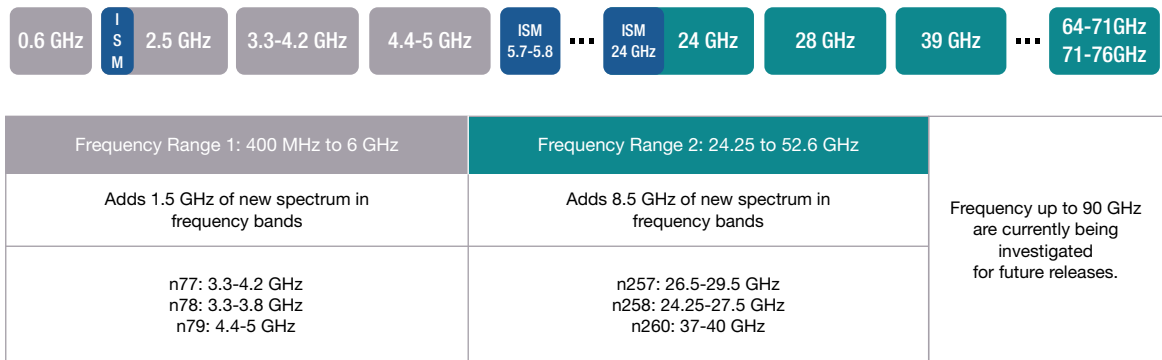

Figure 20.4. New operating bands in 5G NR

In addition, the n257 band spans 26.5 to 29.5 GHz, and the n258 band spans 24.25 to 27.5 GHz. The n260 band spans 37-40 GHz and the n261 band spans 27.5 to 28.35 GHz. These are all overlapping with fixed satellite services ground station uplinks at the 27.5 to 29.5 GHz and downlink at 37.5 to 40 GHz.

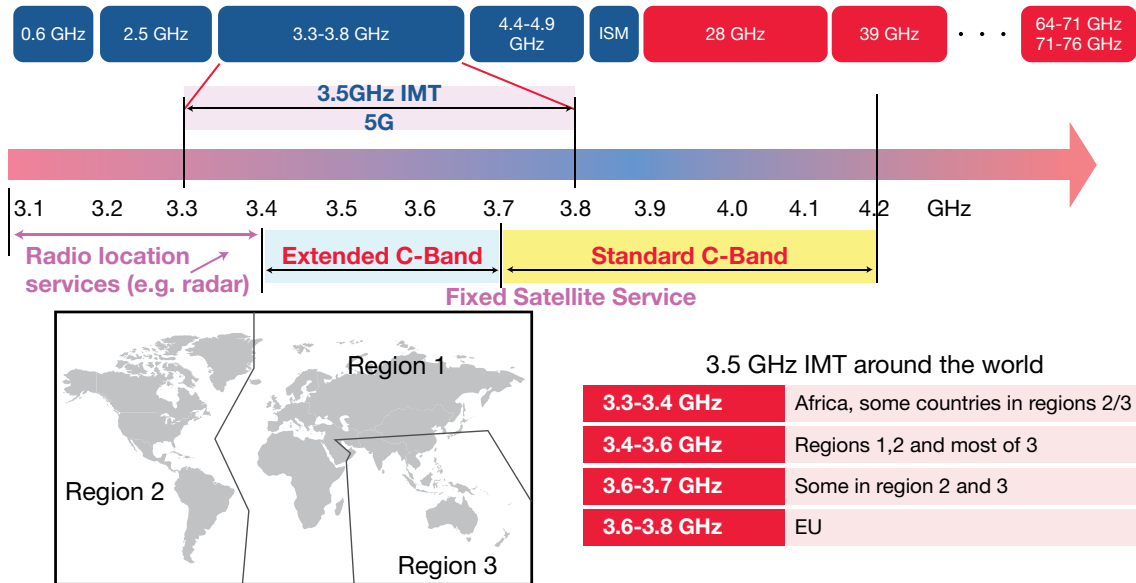

Figure 20.5. Detailed frequency range for 5G NR

Currently, in the US, the entire 3.1-3.55 GHz band is allocated for both federal and non-federal radiolocation services. Federal radiolocation services have a primary allocation and non-federal users operate on a secondary basis. In addition, the C-band and extended C-band are used for fixed satellite services. This introduces a conflict condition between 5G and radar/satellite allocations which is known as coexistence.

Radar Coexistence with 5G

Coexistence is similar to interference, except that two or more signals have the right to occupy the spectrum in question. However, usually one of the signals has priority, typically radar has priority over 5G. Thus, 5G must either shut off or move off frequencies to account for this. The coexistence of 5G and satellite is dangerous because satellite ground stations have very sensitive RF front ends that are designed to receive very lower-power signals from an altitude of 36,000 km. This makes receiver front ends very sensitive to external interference. On the other hand, 5G base stations are strong as they are designed to speak to phones from one to two miles away.

Due to coexistence, it is incredibly important that there be a set of concrete metrics that can be used to assess the signal quality and thus the impact of coexistence. One of the key parameters for signals, in general, is error vector magnitude. Error vector magnitude is the measure of the difference between a measured symbol and the reference symbol in two dimensions (I and Q). The higher the EVM is, the poorer the demodulation will be. A perfectly clean signal will theoretically have 0 EVM. EVM is often expressed in dB or percentage.

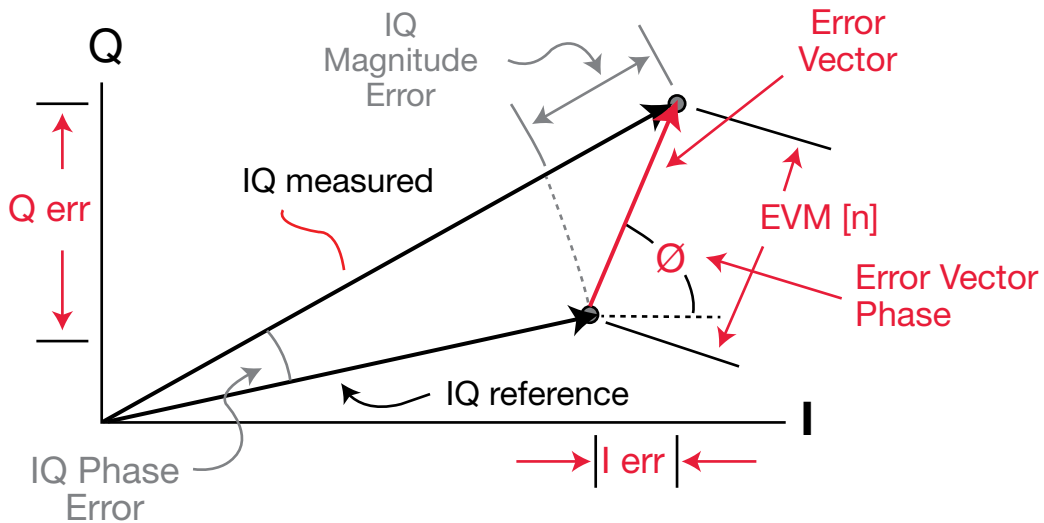

Figure 20.6. Error vector magnitude (EVM)

The 3GPP standard for 5G has laid out EVM requirements for different modulation schemes because the modulation can be changed depending on what the channel can support. If the channel is cleaner and can support a higher-order modulation, which is more signals being transmitted, then it will. In Table 20.1, you can see that the QPSK, the least order modulation, has the highest required EVM, followed by 16 QAM, 64 QAM, and then 256 QAM, which requires a clean channel.

Modulation scheme for PDSCH	Required EVM
QPSK	17.5 % (-15.1 dB)
16QAM	12.5 % (-18.1 dB)
64QAM	8 % (-21.9 dB)
256QAM	3.5 % (-29.1 dB)

Table 20.1. Table shows how 3GPP EVM requirements for user equipment (UE) decrease as the modulation density increases

There are several discriminators for minimizing coexistence conditions. The frequency regulator could set up guard bands and distinct frequency spacing of different services to prevent coexistence. Services could dictate a minimum distance from transmitters. For example, shipborne radars could say that they need to be X miles away from the coast where there may be 5G base stations. Also, the power level can be adjusted to minimize coexistence. Lastly, antenna type, angle, and elevation is another parameter to adjust. Of course, the measurements that would assess coexistence impact are EVM and throughput testing or satellite video signal quality.

A radio channel is the propagation path between a transmitter and a receiver. It includes such effects as path loss, shadowing, multipath and fading, and Doppler.

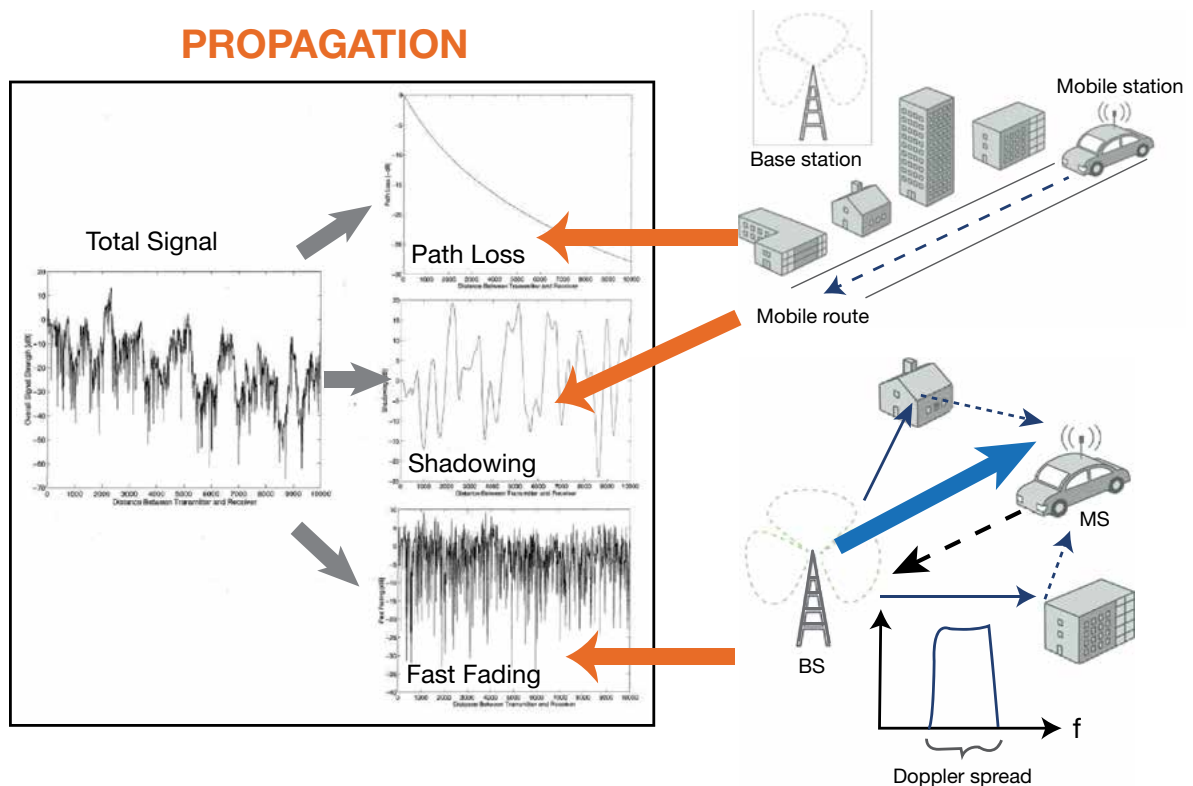

Figure 20.7. Radio channel diagram

The superposition of multi-path components causes fast fading. This is when phases of multi-paths are independently varying and summing together. Distance-dependent attenuation of propagating signals is called path loss. The longer the propagation path, the greater the path loss. Large obstacles between the transmitter (Tx) and the receiver (Rx) create shadowing and cause slow fading. A fading channel affects RF signals between UE and BTS (over-the-air).

As the threat emulation environment is built up, one of the first considerations needs to be the time-base of the system; specifically all emitters need to be phase-locked to the same time base. A fully coherent system is critical for a successful model of threat emulation. In summary, coexistence is between 5G and radar/satellite and is a very real problem in a crowded spectrum. The impact of 5G on radar/satellite

and vice versa can be measured by EVM or by 5G quality metrics. An adequate guard band should be chosen to minimize the issue to the extent possible. Power levels, distance, and antenna orientation are other mitigation parameters. With the ability to measure coexistence, the effects of it may be lessened to provide seamless communication services.

Simulating Non-Radar Background Signals

An important task for an EW receiver is to detect incoming signals (waveforms), identify exactly which station or stations they are coming from, and analyze signal information from all transmission stations. The information coming from a signal transmission station includes the station's location, speed, waveform types, and frequency bands. The signal appearing at the EW receiver input is a combination of signals from different radar or communication transmission stations with complex information for the location and speed of the stations, as well as time waveforms and the frequency bands of transmitted signals. To test the EW receiver, a test signal with the following characteristic is needed:

- It must come from multiple radar and communication transmission stations
- Each component of the EW receiving signal must include information from the transmission station on its location and speed, as well as the time waveform from the station and the signal's frequency-domain information
- It must form multi-emitter, overlapping, or non-overlapping signals

This type of test signal is called a Multi-Dimensional (MD) signal.



Figure 20.8. Shown here is an example of an ew receiver test environment with several geographically dispersed emitters contributing to signal conditions at a centrally-located receiver.

Testing an EW Receiver

To test an EW receiver, a test signal must be generated and that does not mean simply adding several time waveforms together. Instead, a MD signal must be created using a detailed setup. For example, because the EW receiver might be installed on an airplane, car, or ship, the tool that's used to generate that test signal must allow the user to specify the EW Rx station's location, speed, time waveform, and frequency band. Also, for each radar station, the tool must allow the user to specify its location, speed, time, waveform, and frequency band, as all this information is built into the MD signal.

There are 4 steps to generate the test signal:

Step 1: Generate the Tx signal for each Tx with location described by longitude, latitude, and height, as well as speed, the proper time waveform, and frequency content (carrier and Doppler frequency). The required complex Tx comprises:

- An antenna and active array antenna with beamforming
- Pulse and dynamic pulse
- Environment scenarios
- A multi-emitter from radar and communication systems
- An EW receiver test signal with MD information from the radar stations
- A long test sequence with a wide frequency band

Step 2. Determine EW receiver location. Speed also needs to be considered.

Step 3. Combine all Tx signals together to form the MD signal.

Step 4. Prior to the test, verify the MD signal.



EW Test Platform

To test the EW receiver, a test platform is needed in which the MD signal can be built and analyzed. The proposed system will work under actual tactical situations with terrain, numerous threats and targets, plus multiple radar signals and jammers. SystemVue can provide a design and test platform with radar/EW scenarios such as target radar cross section (RCS), interference, jamming, deception, and clutter. With SystemVue, an AGI System Tool Kit (STK) link is provided. This link allows the user to describe complex radar/EW environments under actual tactical situations with terrain, numerous threats and targets, plus multiple radar signals, and jammers simultaneously occurring.

One of the challenges that is often encountered when testing radar/EW systems is how to generate and analyze the MD signals, which include information about monitored Tx stations, such as location, velocity, time, and frequency. Radar and EW environments also include interference, jamming/ deception and this must be taken into consideration when performing measurements under real-world scenarios. A solution to address these issues using SystemVue has been proposed, and simulation and test platforms have been built. Using these platforms, engineers gain access to a myriad of benefits. They provide a true design-oriented value proposition to shorten the development cycle and allow users to save time and money by minimizing field tests. Moreover, SystemVue's multiple environment scenarios enable engineers to create real-world test environments that enable them to design high-quality products. Such capabilities and benefits are critical to ensuring the successful development of modern radar and EW systems. Simulation and test results show custom problems can be solved using the proposed method.



<https://www.keysight.com/see/radar-ew-system-test>



Chapter 21 Validating Jammer Effectiveness

Test systems used to evaluate jammer effectiveness are structured so that each component, depicted as a block in the diagram below, has a specific function and relation with the System Under Test (SUT).

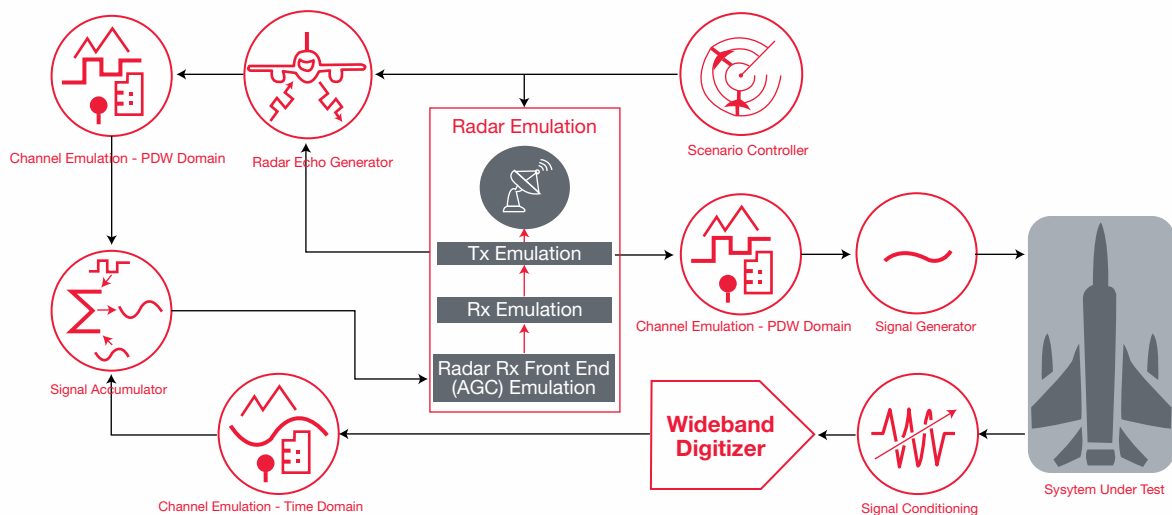

Figure 21.1. A candidate test system to evaluate jammer effectiveness

The overall operation of the system shown in Figure 21.1 is described in the following paragraphs. This ‘thought experiment’ will highlight the types of challenges that will be faced by the implementers of such a system.

Scenario Controller

A scenario controller is a software application (often supplemented by a GPU) that keeps track of the actions of all the objects in the emulated scenario – their positions, velocities, aspects, and relationships with one another. Such applications are broadly available although many of them are not architected for closed-loop operation and can only create a set of signals that would be applied to the SUT, without the ability to emulate a radar in real-time.

It is here that we first encounter challenges in the implementation of this test system:

- The SUT may function and maneuver autonomously, without the knowledge of the scenario controller. This presents the need for a two-way communication path between the SUT and the scenario controller. The scenario controller needs to know where the SUT is at any given time, and the SUT needs to know about the surrounding terrain and other emulated objects so that it can properly maneuver.
- Timing is key – precise timing between all system elements is critical, including the SUT.

Radar Transmitter

Radar emulation is central to the operation of this test system. Depending on the purpose for which the system is to be used, radar emulation may be high-fidelity (emulating a specific radar model) or more general-purpose in nature. In any event, the radar emulator needs to be reconfigurable so that it may be used to emulate more than one kind of radar.

In the system architecture used here, the radar transmitter emulator’s output is a series of pulse description words (PDWs), which describe the pulses that the radar wishes to transmit. The PDWs will change according to the mode of the radar, and the radar emulator must transmit certain information (such as antenna beam direction) to other test system elements.

Radar emulation will likely be implemented with a combination of software and FPGA-based firmware, requiring the ability to reconfigure FPGA contents at will. This will require a new technology development.

Channel Emulation (PDW Domain)

The PDW-based output of the radar transmitter emulator must be scaled to account for the signal path between the radar and the SUT. For simple cases, this may be a simple delay and attenuation factor. More advanced systems will include models for multipath transmission, general scattering, atmospheric absorption, and other factors that may affect the transmitted signal. Channel models must be applied to the PDWs to account for these effects.

But the SUT must participate in channel emulation, and there are other logistical problems:

- The test system knows the beam direction of the radar but not the beam direction of the SUT. This requires a communication path between the SUT and the transmit channel emulator to properly scale the SUT's input signal.
- The SUT antenna might be an array. Full, element-by-element testing of phased array antennas is possible but expensive. Alternatively, the signal may be applied to the SUT at a point behind the antenna if a physical connection is available.
- The SUT might be trying to execute a direction-finding algorithm, requiring a test setup specifically designed to enable direction-finding (with a calibration routine), or the ability for the test system to 'push' direction information into the SUT's controller via a special test mode.

Signal Generator

Fortunately, several suitable signal sources have become available in recent years. Such sources accept the PDW output of the channel emulator and create RF signals to match, which can be applied to the input of the SUT.

Signal Conditioning

The SUT's output must be assumed to be unpredictable and of varying power levels over time. It is important to prevent the SUT's power, which may be quite high, from damaging the input of the downstream receiver circuits. At the same time, the receiver's input power should be in a range that allows the digitizer to operate near full scale so that optimum signal fidelity is maintained.

Signal conditioning can be achieved using a fast gain control circuit (with power protection at the receiver input to handle any transient signals). Preferably, a software interface with the SUT would allow the test system to determine appropriate attenuation levels – obviously requiring cooperation from the SUT.

There is an additional, and unusual, requirement on the signal condition solution needed for this test system. To enable proper signal scaling downstream, the signal conditioning system must communicate its attenuation setting to the rest of the test system. The signal conditioning system must therefore include the appropriate communications mechanism while also participating in system timing functions.

Digitizer (Receiver)

Assuming successful implementation of signal conditioning at the SUT's output, the receiver design may be straightforward. The block diagram in Figure 21.1 assumes the use of a wide-band digitizer of a type that has become recently available off-the-shelf. This type of design does not require a tunable downconverter and may make it easier for the system to handle frequency hopping SUTs. A more traditional downconverter-based design (with a narrowband digitizer) could also be used, in which case the test system must be able to follow frequency changes by the SUT. In either case, an interface with the SUT that allows the test system to follow frequency hops more easily is desirable.

Channel Emulation (Time Domain)

The SUT's captured output signal must be modified to account for channel effects over the path from the SUT to the radar. Although conceptually identical to the channel emulation already discussed, the implementation here is different because the input signal consists of time-domain sampled data (probably baseband IQ data), not PDWs. This requires considerably more processing power.

Commercial channel emulators are available which can perform this function, but their inputs and outputs are usually RF signals, and they are designed for mobile phone applications, so they are not useful in the context of the test system examined in this paper. The underlying technology is available but must be re-implemented in the proper form.

Radar Echo Generator

The total set of signals in the simulated scenario must include radar echo returns. In the very simple case illustrated in Figure 21.1, there are two echo returns: one for the jammer and one for the protected entity. These echo returns must be mathematically generated in software, with channel models applied. These signals are represented as PDWs to keep data bandwidths low, and the channel models are like the functionality already described for the radar's transmitted signals except for the addition of round-trip effects rather than just one-way. The SUT is not involved in this step.

Signal Accumulator

The captured signal from the SUT must be combined with the emulated radar echoes, using precise timing. The signal accumulator block represents a new (but straightforward) technology that must be developed. Note that the echo signals are in the PDW domain while the SUT's output is captured in the time domain, so the signal accumulator must translate PDWs into the time domain. In addition, the SUTs signal will not arrive at the same time as the emulated radar echo signals, so buffering and careful timing is necessary. Once accomplished, the output of the signal accumulator is a time-domain signal that represents the RF signal that would be captured at the radar's antenna.

Radar Receiver Emulation

It is important to properly emulate the radar receiver, including automatic gain control at the receiver's inputs. Many jamming techniques rely on the jammer's ability to manipulate the radar's AGC so that actual echoes are driven down into the noise floor while the jammer's signal is stronger. Radar receiver algorithms must also be implemented. However, the necessary fidelity of radar emulation depends on the specific use case – some systems will require detailed, high-fidelity emulation of specific radars, while others only need general-purpose radar signals of different types and do not need to exactly match any particular model of radar.

Jammer Effectiveness Evaluation

A survey of the industry indicates that there is no standard method for evaluating the effectiveness of a jammer. Jammer effectiveness is at its core a mission-specific measurement. If a jammer can “fool” a radar for five minutes, is that enough? It's easy to see that the answer depends on the specifics of the mission.

More generally, jammer effectiveness should be evaluated on a statistical basis – especially since the jammer may ‘learn’ from one simulated run to the next, and its behavior will be modified by noise, different navigation paths, and its cognitive algorithms.

A standard measurement technique would be helpful. Such a standard would help to avoid confusion and duplication of effort across the field. For now, no such standard exists. This should be the topic of future papers and industry discussions.

System Scalability

It is important to consider the issues that will arise when a test system is scaled up to include multiple radars, jammers, and protected entities. Noting that all radar signals must be applied to all jammers, all jammer signals must be applied to all radars, and all radar echoes must be received by all radars, it can be seen that the complexity of signal and data connections in the system will expand factorially as the system is scaled up. This presents architectural problems that must be resolved to prevent the system from becoming unmanageable

As a subject for future investigation, it is proposed that ring and star architectures be implemented. In these types of architectures, all of the necessary data is broadcast to every part of the test system. System blocks can then listen for the data they need, ignoring the rest. Such architectures are often used to create scalable systems – but these architectures are not common in test and measurement applications, and further investigation will be needed.

Testing cognitive jammers – or any other cognitive system – will require the same level of innovative thought that's required to design the cognitive systems in the first place.

Cognitive systems will have to be full participants in their testing, with software and hardware interfaces included that allow the test system to communicate with the SUT in a peer-to-peer fashion. Designers of cognitive systems will be well-served to consider these requirements early in the design and development process. Otherwise, expensive modifications will be needed to test them later.

Likewise, test system designers will be forced to implement new technologies and new architectures – and the costs of such systems must be included in budgets at an early stage.



<https://www.keysight.com/see/radar-ew-system-test>



Chapter 22 Radar and EW Signal Recording and Analysis

Gap-free recording of a complex RF environment is a practical way to capture elusive and intermittent signals for further analysis via playback and post-processing. The Keysight N9040B UXA and N9030B PXA signal analyzers enable streaming of I/Q data at up to 255 MHz real-time to the X-COM IQC5255B signal record and playback system (Figure 22.1).

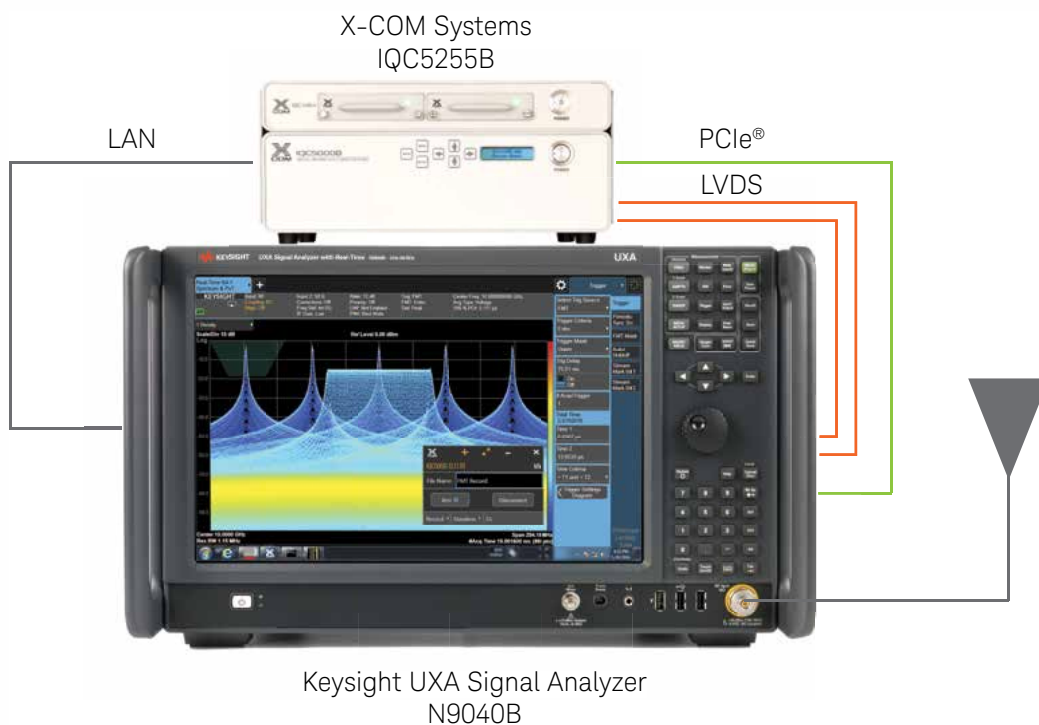

Figure 22.1. Combining the UXA signal analyzer and IQC5255B recorder with powerful software components creates a comprehensive solution for RF streaming.

With up to 15 TB of memory, the IQC5255B can capture more than three hours of data at full bandwidth. Table 22.1 provides approximate recording times based on the bandwidth setting in the UXA.

Bandwidth	Approximate Recording Time			
	Memory	Seconds	Hours	Days
10 MHz	15 TB	300 k	83.3	3.5
100 MHz	15 TB	30 k	8.3	0.35
255 MHz	15 TB	12.5 k	3.5	0.14

Table 22.1. Maximum recording time is a function of available memory and analyzer bandwidth setting.

Configuring and Recording Seamlessly

When the environment contains numerous emitters of varying amplitudes, it can be difficult to find low-level signals in the presence of much larger ones. In the streaming solution, the PXA or UXA provides 78 dBc of spurious free dynamic range (SFDR) across the full 50 GHz frequency range, and this is recorded with the high-resolution 16-bit I and Q capture capability of the X-COM recorder to produce deeper views of signal behavior.

Seamless integration between the analyzer and recorder enables you to configure and initiate recordings directly from the UXA or PXA, streamlining recording control and eliminating the need for an external PC or laptop. An added benefit is the ability to simultaneously view the live spectrum measurements on the analyzer screen while a recording is in progress (Figure 22.2).

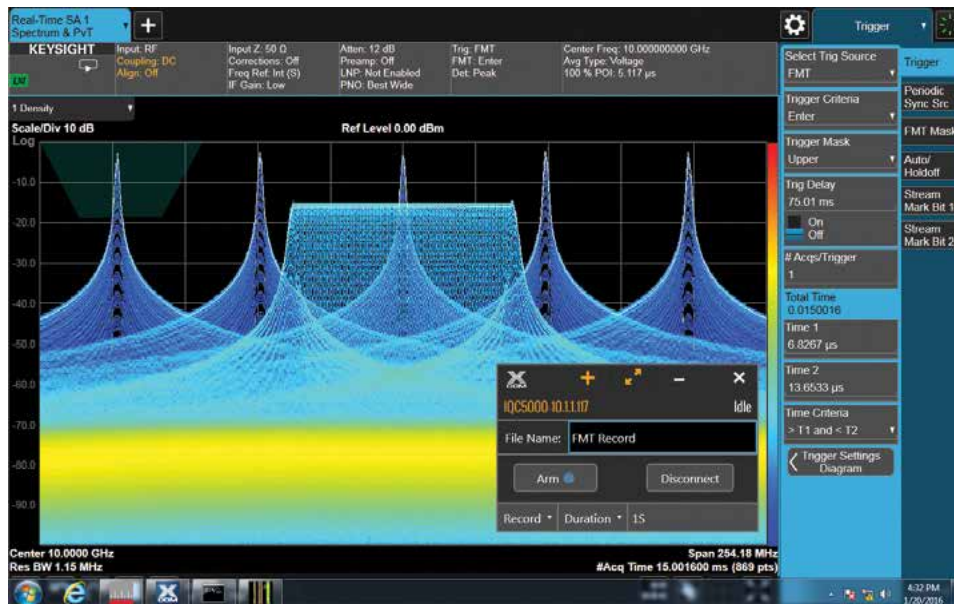

Figure 22.2. Real-time spectrum analysis (RTSA) mode provides live measurements of elusive signals even while recording is underway.

Extracting Useful Information from Massive Data Sets

This is a “big data” process. Streaming 100 MHz of I/Q bandwidth with 16-bit samples for just 10 minutes creates a 300 GB file. Today’s RF streaming applications routinely require bandwidths above 200MHz.

With a modern interface such as PCIe, large files can be offloaded from the IQC5255B’s redundant array of independent drives (RAID) array to the analysis computer (in the UXA) with nearly gigabyte-per-second speeds. Once the data has been captured and stored as I/Q samples on the IQC recorder, it must be analyzed, interpreted, and distilled into more compact forms such as mission data file (MDF) entries or pulse descriptor words (PDWs).

Advanced signal processing tools are needed to turn this raw data into useful information and actionable results. For example, the ability to search through large sets of data and isolate specific signal behavior is essential to helping a system engineer or signal analyst determine whether the system performed as expected or if there were any timing anomalies or unexpected RF emitters.

X-COM’s Spectro-X software allows you to quickly zoom in on desired recording segments using automated signal- and pulse-search algorithms. It includes functions that range from basic frequency, time, or amplitude filtering to highly advanced pulse pruning based on pulse width, pulse repetition interval (PRI), and more. This level of functionality makes it easy to search through vast sets of data and uncover rare events or signals (Figure 22.3).

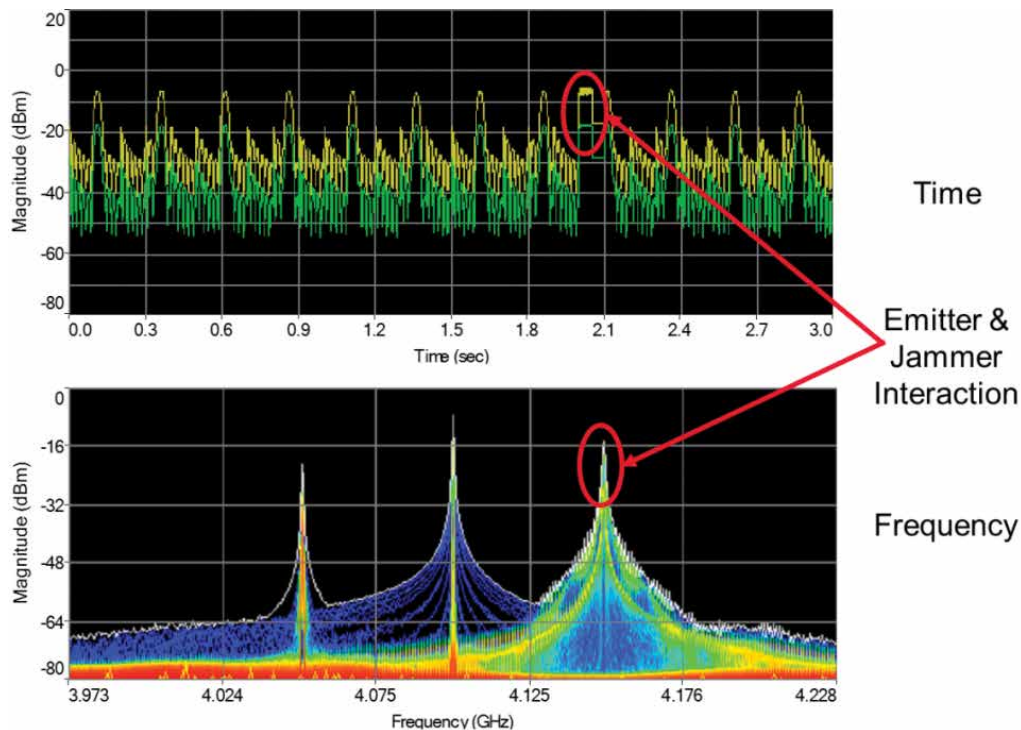

Figure 22.3. Whether viewed in the time (top) or frequency domain (bottom), Spectro-X software helps detect short-lived signal behaviors as in this interaction between an interceptor radar and a jamming response. Note the relatively short duration of the interaction compared to the other scanning radars in the background.

With the real-time streaming option on the UXA and PXA signal analyzers (Option RTS) combined with the X-COM Systems IQC5255B, you can now capture and record I/Q signatures of complex pulsed radar signal environments, enabling signal characterization and system verification. This comprehensive solution also includes scenario emulation through the ability to play recordings through a vector signal generator. With seamless integration and accessible usability, the streaming solution from Keysight and X-COM can help you push the envelope in next-generation radar and electronic warfare systems.

RF Streaming for Aerospace & Defense Applications

Some systems record at either RF or IF, necessitating digital down conversion to baseband. Whether the down conversion occurs digitally or using RF circuitry, Figure 22.4 below highlights the process for turning large volumes of raw IQ data samples to mission data file entries or pulse descriptor words.

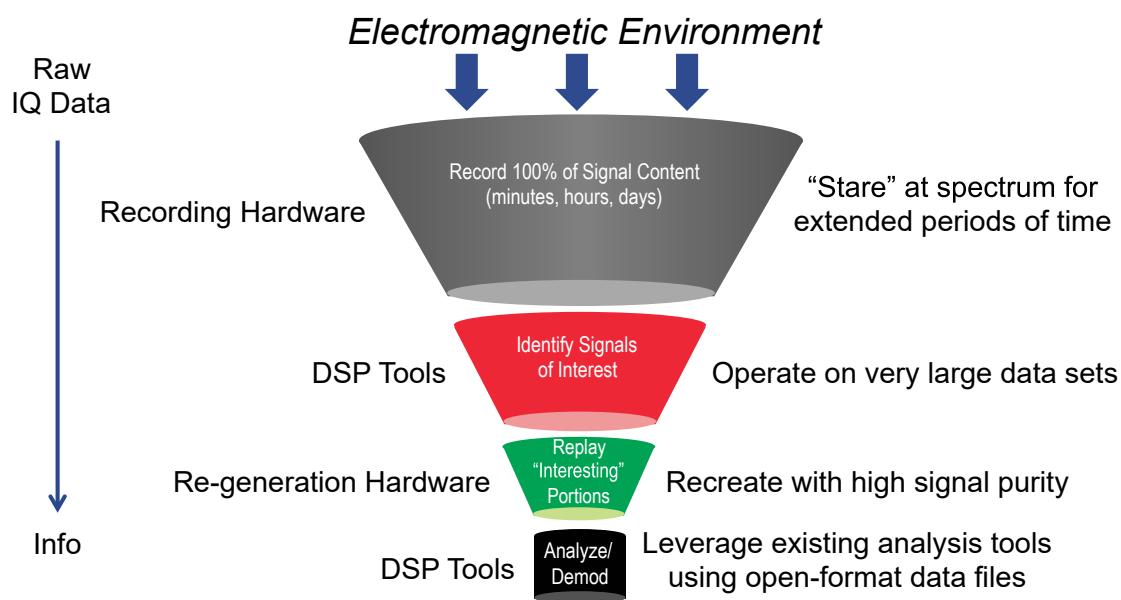

Figure 22.4. RF energy is first stored as IQ samples where DSP tools are used to identify and demodulate signals of interest. These stored IQ samples can also be used for signal playback or combined with other signal files for scenario simulation.

RF streaming is big data. With 16 bit resolution on I and Q, streaming 100 MHz of IQ bandwidth for just 10 minutes would create 300 GB of data. Modern RF streaming applications routinely require bandwidths over 200 MHz.

Thanks to modern digital interfaces and fast solid-state disk drive technology, recordings can be streamed directly to the disk from the digitizing hardware. Wider streaming bandwidths require the data stream to be split and fanned out to slow down the individual write rates to each disk. The parallelization of data writing (and reading) is a storage management technique for a RAID.

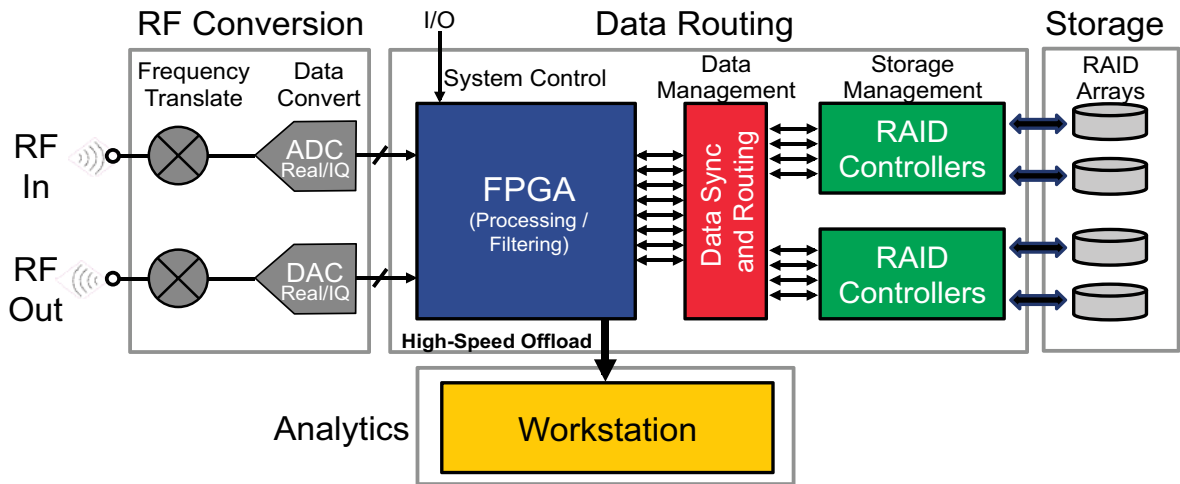

Figure 22.5. Each link in the streaming solution is designed to meet or exceed data throughput requirements

RF Streaming Collection Model

Figure 22.6 below is an example of a recording environment where all the above issues will come into play. In this case, the RF streaming solution will be on-board the Northrop Grumman E2-C Hawkeye surveillance aircraft, with a mission of recording the RF interaction between the interceptor aircraft radar (blue) and the UAV jammer (red). The data collected will also include the two surveillance radar signatures (blue) occurring in the background.



Figure 22.6. An RF streaming solution is placed on-board an E2-C to record the interaction between interceptor radar and jamming response from the UAV.

RF Streaming Requirements

There are four main performance considerations in any RF recording system

- RF frequency coverage and analysis bandwidth
- Spurious Free Dynamic Range
- Record time
- Metadata inclusion

The first is the amount of bandwidth needed to capture the signals of interest. Even for multi-channel recording systems, the engineer must determine how much IQ bandwidth is needed to capture the signal in its entirety. Extracting pulse descriptor words from a signal that straddles more than channels is very difficult. Furthermore, the streaming bandwidth should exhibit flat amplitude response and excellent phase linearity to minimize distortion to the data. Poor IF flatness will manifest as poor ACPR or EVM on a communications signal or phase errors on chirped radar pulses.

The second determinant in recorder selection is SFDR, which represents the lowest amplitude signal that may be discerned from a large interfering signal. As defined by the ratio between the power of the carrier signal and the RMS power of the next most significant spurious signal, it represents the sensitivity of the measurement system to small signals. In pulse-Doppler radar signal processing, targets are often represented in terms of their range and velocity.

Simulating the Threat Environment

RF streaming on mission day should be, well, boring. To complete the RF streaming portion of the exercise, the operator needs to collect the required IQ signatures and bring these back so the system engineer or signal analyst can begin data analysis. In this regard, it is important to prepare for what you expect to happen, but also to plan for what you don't. Figure 22.7 below illustrates our expected radar-jammer interaction on mission day. Note the timing relationship between the Blueforce (blue pulses) and Redforce (red pulses) signatures. Two important timing measurements are as follows.

- The response time between the first Blueforce transmit pulse and the first reply by the Redforce jammer.
- The reaction time of the Redforce EW system, between when the Redforce radar warning receiver (RWR) recognizes a potential threat and its first reply.

A live measurement cannot be performed on mission day, since this would require access to the Redforce EW system test points. However, this measurement can be performed in a chamber if both Redforce and Blueforce systems are available.

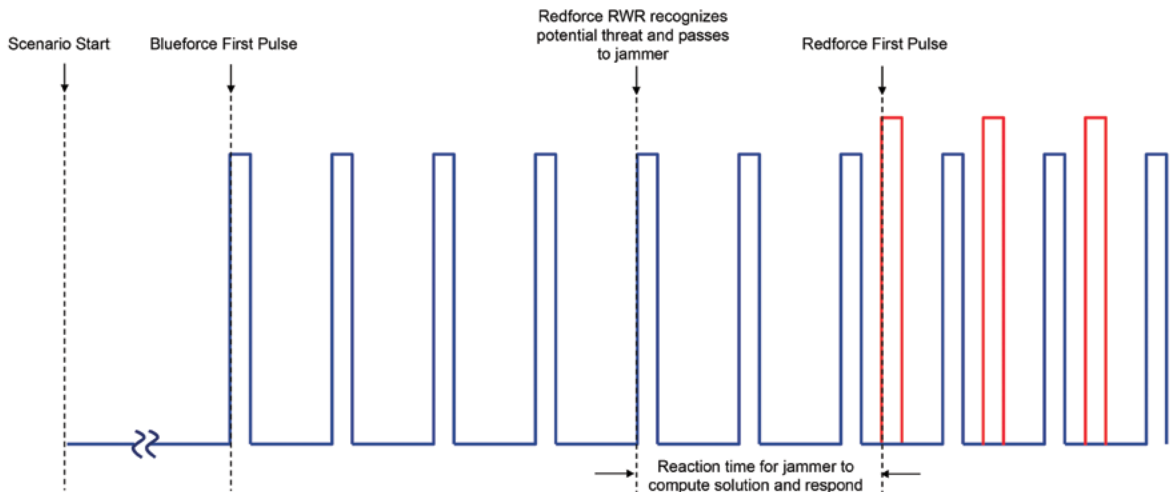

Figure 22.7. Radar-Jammer response timing. Blueforce initiates pulses which are detected by the Redforce RWR. The Redforce then initiates a credible jamming signal as quickly as possible. Both Redforce reaction times are critical measurements.

These emitters and their relative timings may be simulated by combining the RF outputs of two precision signal generators and feeding their combined output to the receiver of the RF streaming system. This is shown below in Figure 22.8 with the environment simulation on the left and the RF streaming solution on the right. The initial Blueforce and Redforce pulses can be time tagged by connecting the trigger outputs from the RF signal generators to the marker inputs of the IQC5255B recorder streaming solution.

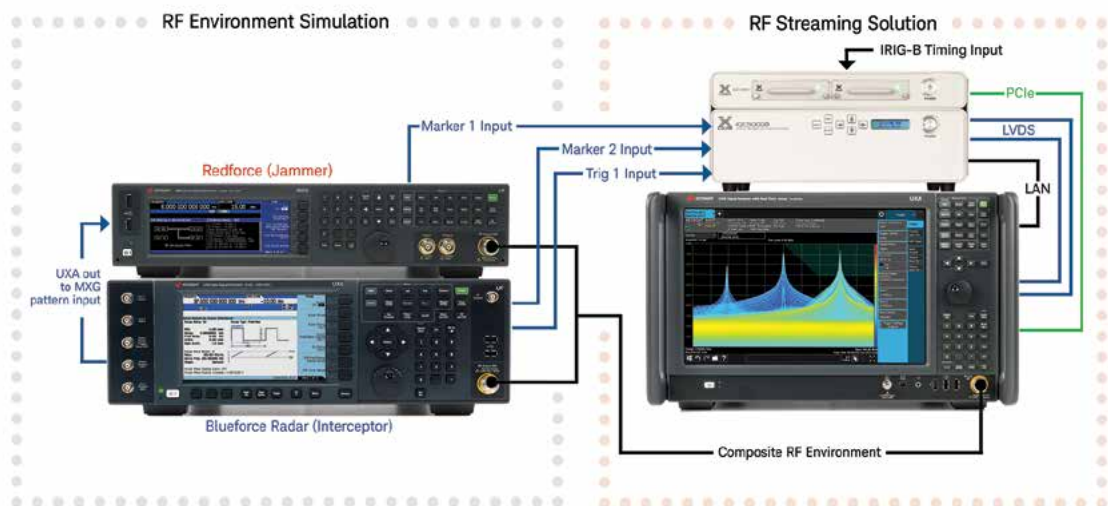

Figure 22.8. Example setup to simulate the Blueforce (radar) and Redforce (Jammer) timing and event recording. The IQC5255B recorder accepts both marker and trigger inputs from the signal generators, along with high-speed LVDS IQ data from the UXA signal analyzer.

Post-Mission Analysis and Simulation

After data has been collected, questions abound. What happened on mission day? Figure 22.9 below shows the magnitude response of a 3-second interaction between the interceptor radar and the jamming response. Note the relatively short duration of the interaction compared to the other scanning radars in the background.

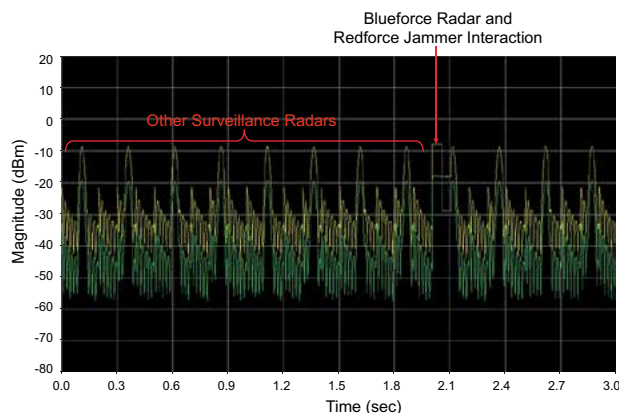

Figure 22.9. Magnitude profile of RF environment during radar-jammer interaction. The top yellow trace is the maximum value of the magnitude response while the lower green trace is the RMS value.

By zooming into the time-domain profile of the Blueforce/Redforce interaction, it is easy to see the relative timing between the first Blueforce pulse and that of the Redforce (Figure 22.10). Precise measurement of the timing relationship between the two emitters can be made with plot markers. Also, note the signal anomaly that appears after the fifth Blueforce pulse. The question for the system engineer to determine is whether the anomaly is radiating from the Blueforce aircraft or the Redforce.

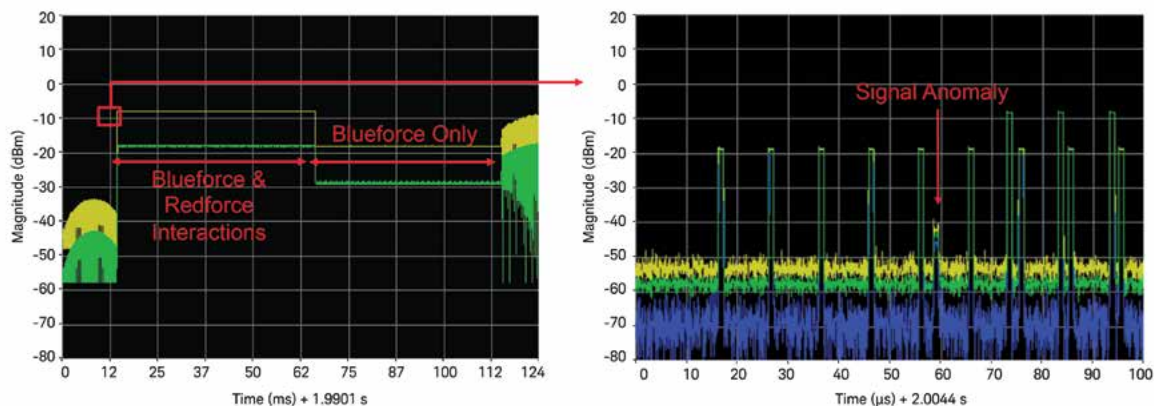

Figure 22.10. Successive zooming on the time-domain plots can reveal signal details down to the sample level.

Once a time segment has been identified for study as in Figure 22.10 above, the interaction can be replayed in both frequency and spectrogram (joint time-frequency) domains for visual inspection.

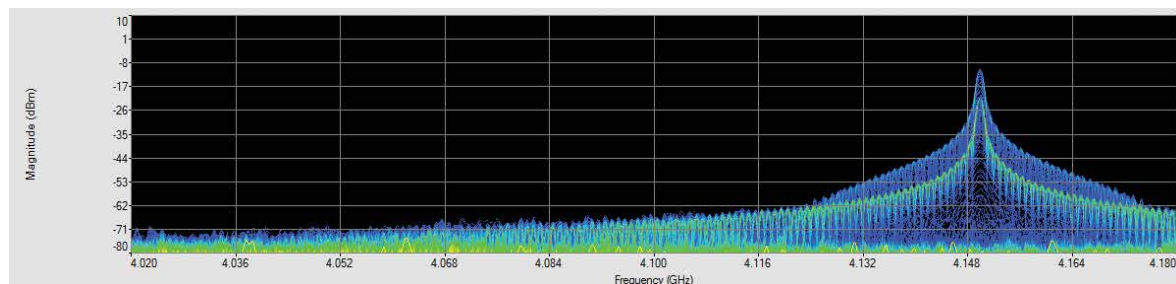

Figure 22.11. Persistence density plot of emitter jammer interaction.

Areas of interest may be further analyzed by Keysight's 89600 VSA (vector signal analysis) software. A summary of the pulse signals contained in the zoomed time range above is shown below in Figure 22.12.

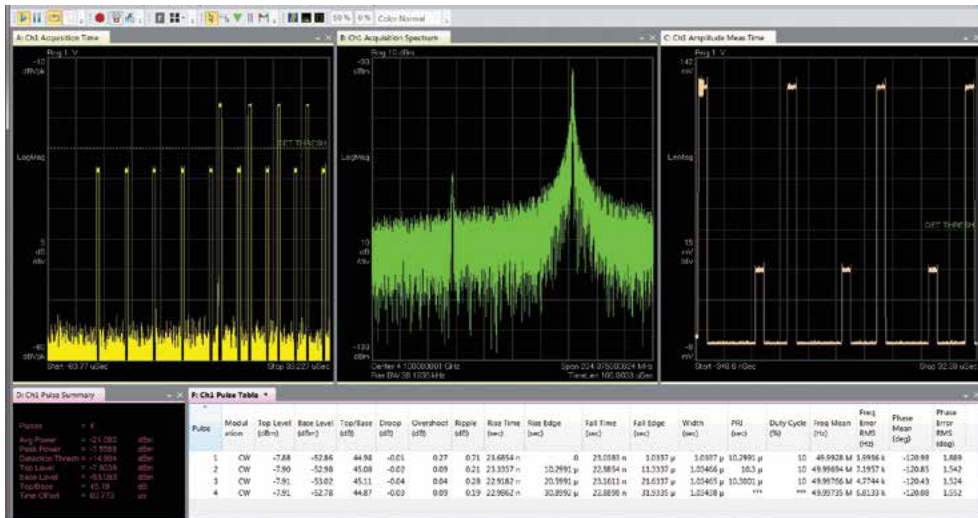

Figure 22.12. Automatic pulse parameter calculation speeds validation of PDW performance against design objectives.

Using the spectrogram function in the signal processing toolbox, we can reproduce the time-frequency plot shown above, but in 3-D. Below, we indicated the signal anomaly with a marker. This is likely a numerical artifact, as we find it shows up at the frequency limit of -100 MHz.

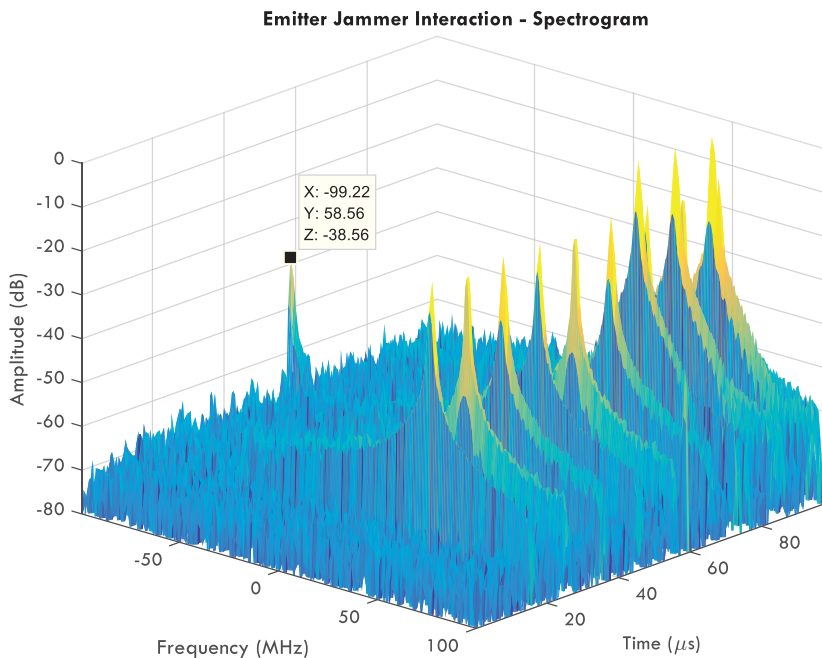

Figure 22.13. Spectrogram plot of emitter-jammer interaction.

RF streaming provides system engineers undeniable proof of what happened over long time durations. Keysight and X-COM Systems have teamed to develop a wideband, integrated solution that offers exceptional fidelity (SFDR and IF flatness), IQ data resolution, analysis bandwidth, RF frequency range, and gap-free recording capacity. While other vendors offer all-in-one packages as well, the X-Series signal analyzers and IQC5000B recorders offer the highest recording performance in the industry. Furthermore, with software tools such as Spectro-X, 89600 VSA software, and MATLAB, users can accelerate their time-to-answer to reduce overall costs.

Using RF Recording Techniques to Resolve Interference Problems

Radar receiver sensitivity is critical for electronic warfare. The sensitivity of both the radar receiver and the radar transmitter must be accurate, precise, and repeatable. Sensitivity measurement accuracy directly relates to power level accuracy — as the radar signal must be strong enough to cover the required distance. Failure of the radar receiver to decipher signals properly from long distances is not an option for military applications.

Measurement Challenges

Generally speaking, there are two primary goals of RF interference testing: to ensure interoperability and compatibility. Interoperability testing focuses on design compliance to a published standard, as well as margin testing, which helps engineers understand how well a system meets design criteria in the presence of real-world signal levels and interference. Compatibility testing, on the other hand, focuses on the “unintended interactions” between a system-under-test and other RF systems.

It's important for engineers to understand whether radios from different vendors can interoperate with one another, as well as if all the systems in an RF environment can play together nicely. Ascertaining a system's susceptibility to impact from and on other RF assets may also be critical.

To better understand why this approach falls short consider the high-level block diagram of a typical signal analyzer shown in Figure 22.14. The main limitation to long-duration recording is that test equipment typically has limited on-board memory.

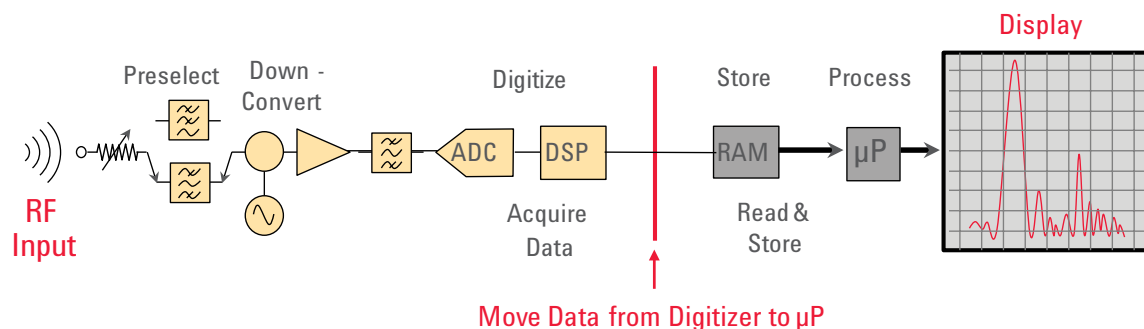

Figure 22.14. Shown here is a typical signal analyzer block diagram.

The signal analyzer does not capture any samples while it post-processes the previously captured data, effectively creating a gap in its data acquisition. Consequently, if events occur while the previous event is being processed or if the new event lasts longer than the available memory, it falls into this gap and may be missed. Moreover, the analyzer's trigger setup only captures signals for one set of limited conditions. Once the analyzer fails to capture the event, it is gone forever.

Introducing Gapless Recording

While resolving RF interference problems in complex RF environments can be a tricky task, the gapless recording offers a viable solution to the measurement challenges presented by the typical signal analyzer. The technique solves the problem of not knowing when or where an interference event will occur, or how long it will last, by enabling continuous acquisition of data over long durations. Because there is no gap in the data recorded, the signal-of-interest, such as an intermittent RF event, is easily captured.

For comparison purposes, consider the data acquisition from a typical signal analyzer with limited on-board memory, as shown in Figure 22.15. Note the gaps in data that occur once its memory is filled up.

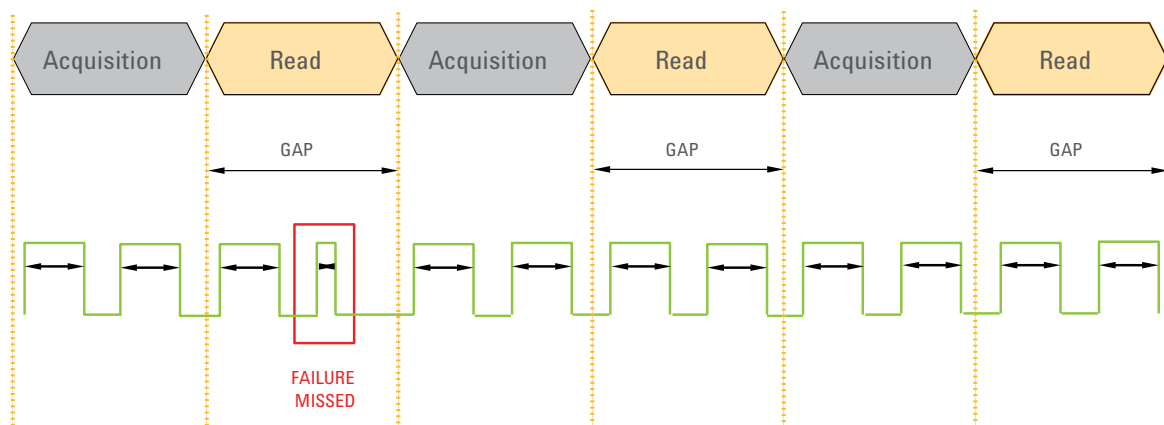

Figure 22.15. With a typical analyzer, once its memory is filled up, data is “read” from the digitizer to the microprocessor for processing and display. During this “read,” any new samples available at the digitizer cannot be processed and are missing, creating a gap in the continuous acquisition of data and resulting in failures being missed.

Now, consider an example of a signal analyzer modified for gapless recording (Figure 22.16). It is the same signal analyzer shown in Figure 22.14; however, it now includes a high speed data link or bus that allows the engineer to move data from memory as it is acquired.

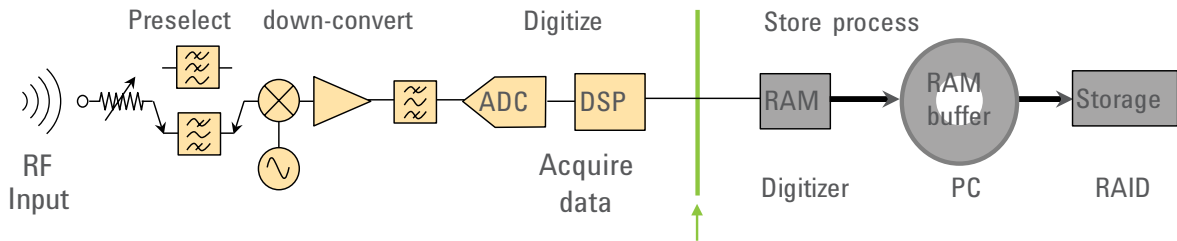

Figure 22.16. A signal analyzer modified for gapless recording.

Keysight's gapless recording system is available in predefined packages that have been tested to guarantee sustained data rates. The configured systems include data interface cards and modules and can be used with Keysight's 89600 VSA signal analysis software.

Real-Time Recording and Analysis

Architecting a real-time radar recorder

The aerospace and defense industry investment in threat simulation systems is increasing in line with the complexity of the electromagnetic battlefield. Most current analysis hardware is limited in capability, resulting in spot-checking signals using spectrum analyzers or high-end oscilloscopes. In addition, there is a need to accurately validate the system under test stimulus and output to ensure correct operation while capturing and recording signals of interest all the time needed to truly validate the proper operation. Most current analysis hardware is limited in capability, resulting in spot checking signals using spectrum analyzers or high-end oscilloscopes. Thus, capturing and recording signals of interest all the time is needed to truly validate proper operation. Keysight's radar recorder's capabilities and features are targeted to solve these problems in the aerospace and defense industry.

Understanding RF system use cases

There are numerous personas with different personalities within the radar industry that exhibit different areas of focus. RF systems engineers typically know what the outbound pulses look like. Thus, they are focused on generating accurate pulses and looking for impairments caused by the realities of the actual hardware. If they find a badly formed pulse, they will need to understand why and how to fix the component or the subsystem responsible. On the other hand, radar analysts typically collect large volumes of RF data on a test range and check whether the overall system responded appropriately to an external threat. If they don't want their signals to get jammed, they need to know what the signatures are of different radar equipment by comparing what they are measuring against a catalog of known pulse trains.

In original recorder systems, a workflow associated with the production-oriented testing that the recorder will witness is needed. Overall lab time was expensive and multiple users competed for time slots, thus making the most of allocated time with the recorder a priority. In this model, recordings are done in a batch fashion with recordings piling up as needed for initial analysis and secondary analysis. In a new recorder system, the system needs the capacity to hold TB's of data and migrate that data from the recording portion of the system to the analysis portion as quickly as possible so that some analysis can be done while the recording is in process as well as in parallel with the next recording.

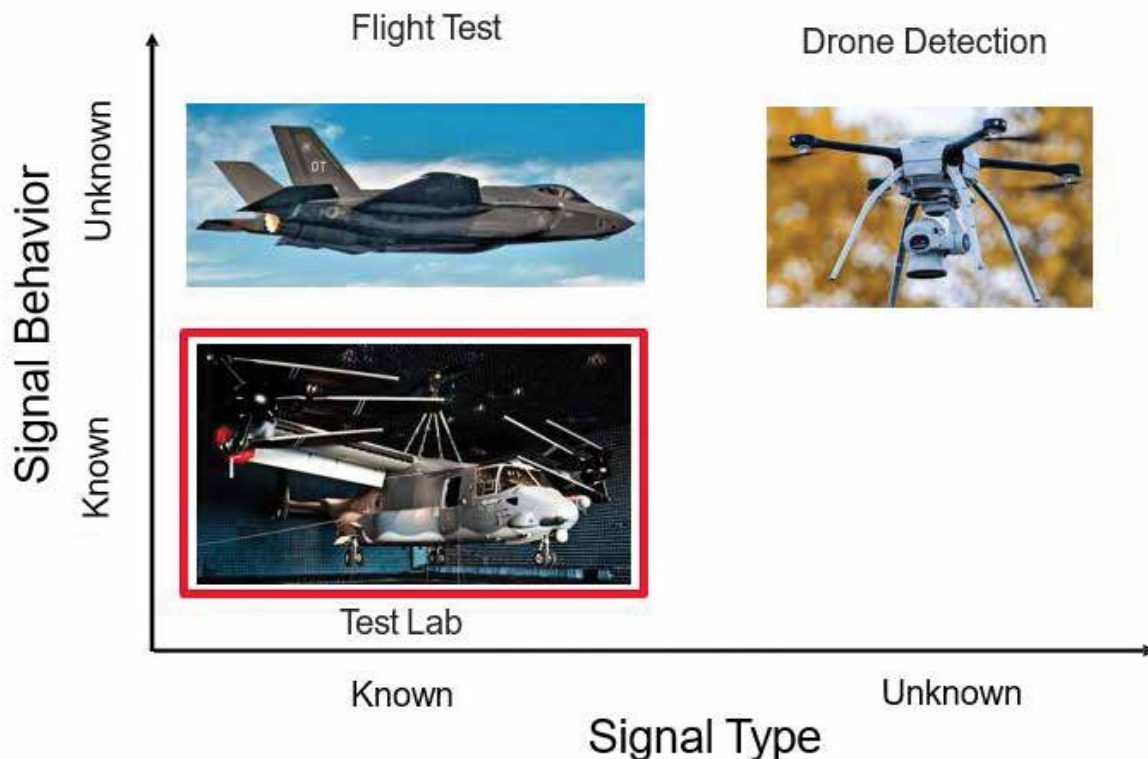

Figure 22.17. RF recording use cases

There are four main types of RF Recording use Cases: Known/Known = System validation/stress testing, Known/Unknown = Threat Assessment, Unknown/Unknown = Spectrum monitoring, Unknown/Unknown = Difficult test parameters. Today's focus area is in system validation and stress testing in labs and its main benefits are that it validates the test source with every pulse and acts as a witness recorder for hardware in the loop (HITL) testing.

Radar Recorder Use Cases

There are 2 known applications for a radar recorder: emitter validation and jammer validation. Emitter validation is important because it provides confidence that a platform will perform correctly in real engagement, outdoor range testing is very expensive, and there is limited time available for reprogramming. It provides quantitative verification of intentional stimulus. Jammer validation is a qualitative technique analysis and is also a statistical analysis of input vs output.

Emitter validation today is focused on the mission of validating the output of the radar or threat simulation platform by measuring PRI, pulse widths, amplitude, frequency, and more. Its main purpose is to provide insight into radar modes of operation and scan patterns.

Jammer validation today is focused on the mission of confirming the expected output of the EW system under test (SUT) or jammer system. It does this by measuring PRI, pulse widths, amplitude, frequency, and more and its main purpose is to provide insight into techniques such as pull-off rates, J/S, multiple false targets, and more.

Validation is important as it provides confidence that a platform will perform correctly during engagement. Reprogramming is time-limited as test labs have around-the-clock usage and testing is expensive, especially in outdoor ranges. Thus, the more that can be done in the lab to ensure that the SUT will perform properly helps ensure proper performance later.

Modern EW threat analysis faces challenges in long simulation time, wideband analysis, and agile emitters. Thus, Keysight's radar recorder resolves these challenges by being multichannel and agile. Threat simulators are inherently multichannel or multiport, measuring AoA is important for scenario validation, and direction-finding is of interest. These 3 facts support the need for a multichannel radar recorder. In addition, emitters and threats occur across frequency bands, with communication and radar signals often occurring at the same time. Keysight's radar recorder also utilizes absolute timing as there is a need to analyze time-synchronized events and it is easier to do so when there is an understanding of when recorded events occurred. In addition, a streaming recording architecture is needed as test scenarios can range from seconds to hours. Thus, a high rate, gapless data capture system is needed which is often beyond the capabilities of ethernet.

Capabilities of a Real-Time Radar Recorder

A real-time radar recorder contains the following set of capabilities:

- A multi-channel, integrated RF recorder
- Real-time measurement of pulsed RF signals
- Hours of RF data recording storage per channel
- Real-time scoring of measured pulses to reference definition
- Suite of pulse analysis software

Real-time radar recorders split up these capabilities between various steps that occur while the data is being acquired and after the data has been acquired. Recording can overlap with data offload analysis. There is an unspoken time order because data must first be acquired to be analyzed, a series of recordings can overlap with a series of analyses, thus boosting throughput. In addition, off-system analysis can be possibly integrated into this process to archive the recorded data. Not every use model will require off-system analysis, but this is a great feature that real-time radar recorders can provide.

Therefore, real-time radar recorders provide multiple levels of analysis ranging from aiding in determining the current status of a test, visualizing data on the analysis workstation, and offloading data into other analysis systems.

Real-time radar recorders can be used both as a threat simulation validation tool and as a tool to witness recording EA system output. These systems allow for input vs output jammer analysis, enable faster time to confidence in testing, provide the ability to view large amounts of data in a more meaningful way, and are scalable in size. Thus, these recorders appeal to the two personas in the radar industry mentioned earlier as the recorder can collect and analyze large amounts of data both during data collection and after.

Keysight's radar recorder features:

- Selectable bandwidth, and multichannel options
- Real-Time PDW scoring
- PDW domain big data analysis software
- Scalability

These 4 main features together allow for input vs output jammer analysis, enables faster time to answer and increased confidence in testing, allows the user to view large amounts of data in a more meaningful way, and has large or mid system applicability.

Exploring Keysight's range of COTS solutions

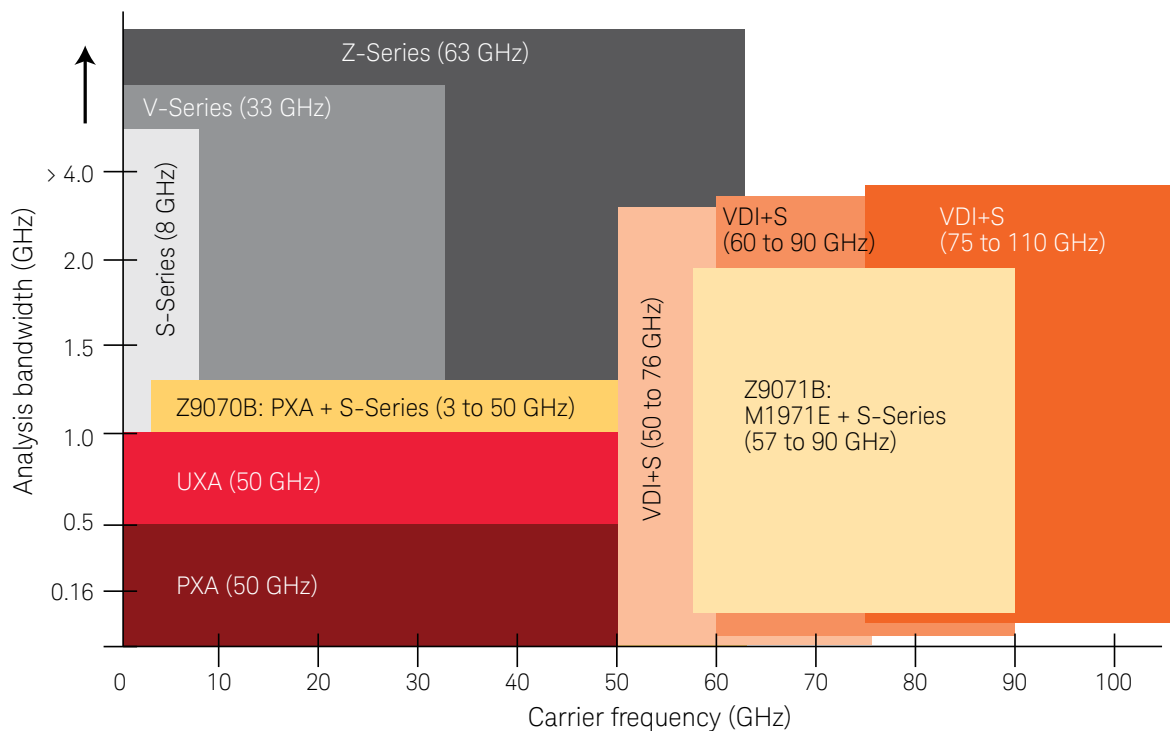
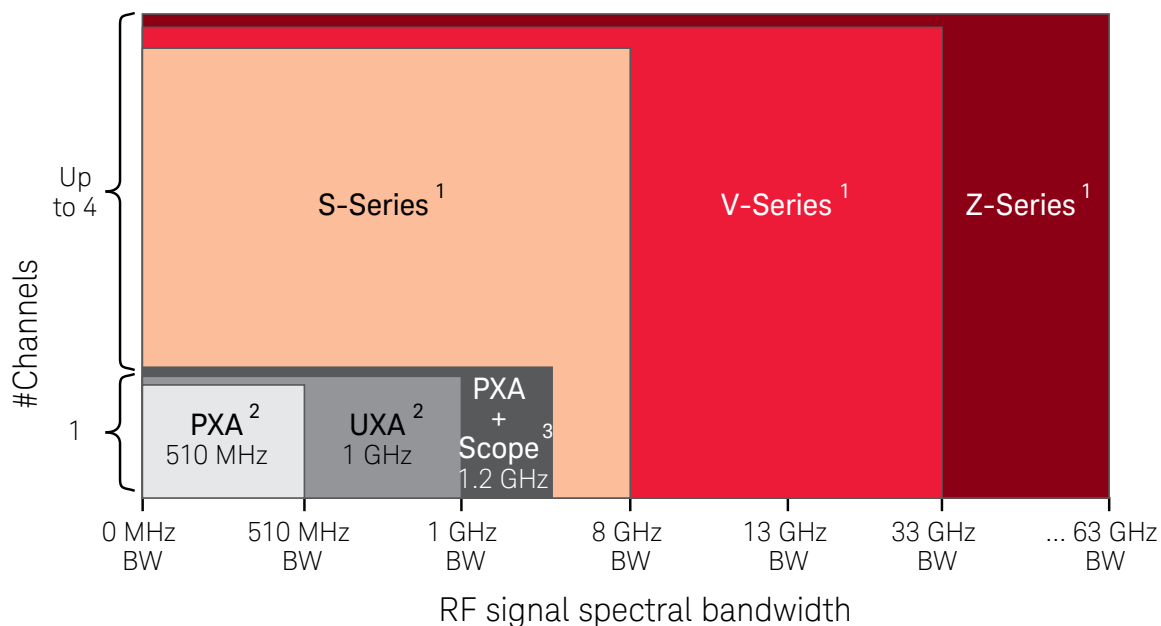

Figure 22.18. Determining the best-fit tool depends on the carrier frequency and the required analysis bandwidth

Another factor is the number of simultaneous measurement channels needed to accelerate measurement time. This can be an important consideration when characterizing phased-array radar systems that contain dozens or hundreds of transmit/receive modules. Figure 22.19 maps analysis bandwidth versus number of channels for a variety of Keysight oscilloscopes and signal analyzers.



1. S, V and Z-Series 2 ch full bandwidth, 4 ch half bandwidth.
2. Up to 50 GHz carrier.
3. 3.6 GHz to 50 GHz carrier.

Figure 22.19. Channel count versus bandwidth is another important consideration when selecting a wideband measurement tool.

The one-channel PXA signal analyzer can measure signals with carrier frequencies up to 50 GHz and offers up to 510 MHz of analysis bandwidth. Similarly, the single-channel UXA can handle carrier frequencies up to 50 GHz and offers a maximum analysis bandwidth of 1 GHz. Note that it is possible to link multiple PXAs or UXAs to create a multi-channel solution.

An S-Series oscilloscope provides two channels with 8 GHz bandwidth or four channels with 4 GHz bandwidth. The V-Series oscilloscope offers two channels with 33 GHz bandwidth or four channels with 16.6 GHz bandwidth. The Z-Series oscilloscope offers two channels with 63 GHz bandwidth or four channels with 32 GHz bandwidth.

An oscilloscope can handle signals with spectral widths nearly up to its bandwidth. One requirement: the carrier plus modulation must be sampled with enough bandwidth to capture both. For example, a signal with a 6 GHz carrier and a 2 GHz wide modulation would fit within the 8 GHz bandwidth of an S-Series oscilloscope and could therefore be evaluated.

Utilizing a wideband signal analyzer

The UXA offers a big step forward in usability by providing factory calibration and operational alignments across the full 1 GHz bandwidth. Integration into the signal analyzer delivers several other benefits: 1 GHz coverage across the full frequency range (3 Hz to 50 GHz); seamless switching between swept, vector, and real-time measurements; and easy operation through the streamlined multi-touch user interface (UI). This combination of capabilities enables informative measurements of pulsed signals in less time (Figure 22.20).

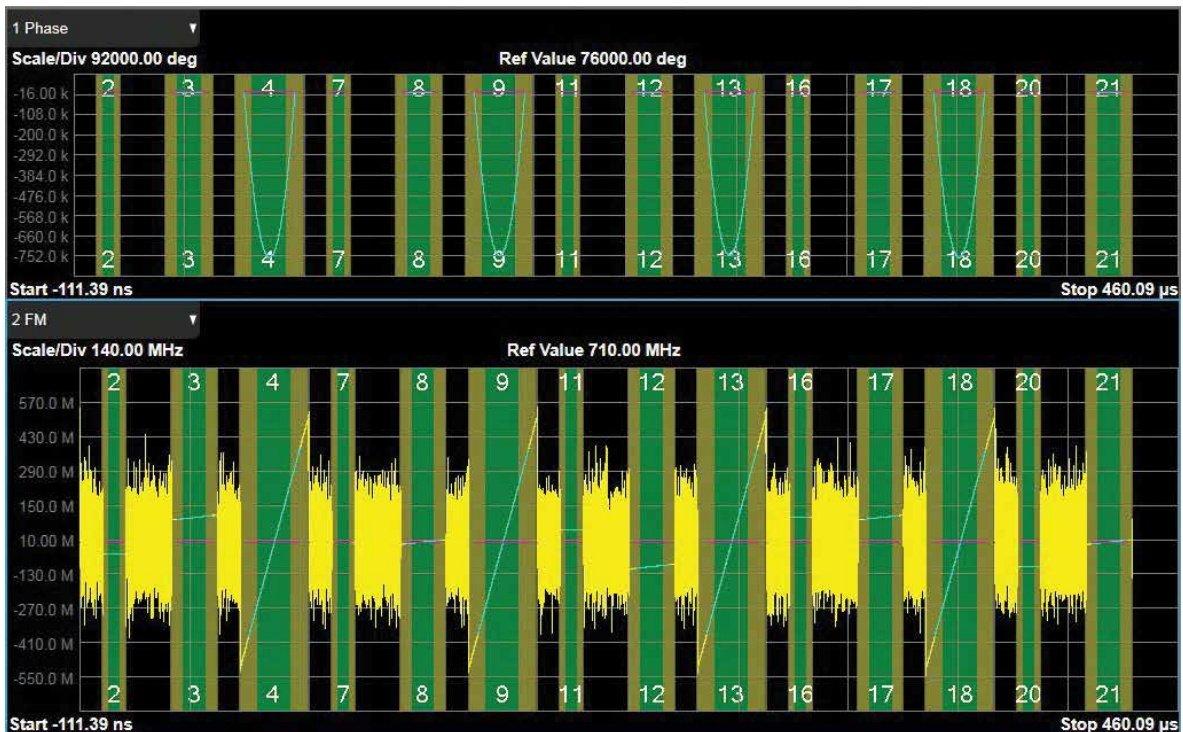

Figure 22.20. The UXA's wide integrated bandwidth simplifies the measurement of linear FM-modulated pulses.

A wideband analyzer also offers benefits in measuring narrower pulsed signals. For example, when measuring pulse rise-times or viewing parameters such as overshoot or droop, the wider analyzer bandwidth offers a faster sample rate, providing more resolution for these measurements.

It's also important to see multiple emitters in any radar or EW signal environment. These emitters likely will also have some intra-pulse modulation and can occur over a wide bandwidth. The UXA can capture multiple emitters across 1 GHz of bandwidth and calculate statistics over a long period. In addition, the optional N9067C pulse application automatically detects and analyzes pulses, providing comprehensive results that enable the full characterization of captured pulses.

Using an oscilloscope

For RF designs that need bandwidths greater than 510 MHz or 1 GHz, a digitizing oscilloscope is an important tool that can assume the role of a “wideband RF receiver.” In these applications, the Keysight Infiniium S-Series, V-Series, and Z-Series oscilloscopes can be used to make a variety of FFT and wideband RF measurements, and the input channels are magnitude-flat, phase-linear and phase-coherent. Analysis capabilities include built-in math programming, and these functions can also incorporate custom, MATLAB-based programs or algorithms.

The high sample rate and deep memory available in Keysight oscilloscopes make it possible to capture a radar pulse and extract its envelope information and the embedded coding. Many of the capabilities built into today’s scopes also support detailed troubleshooting and analysis. For example, the scope can directly digitize a signal at RF or IF and then process the signal with internal math functions to plot a histogram or calculate parameters such as absolute value (Figure 22.21).

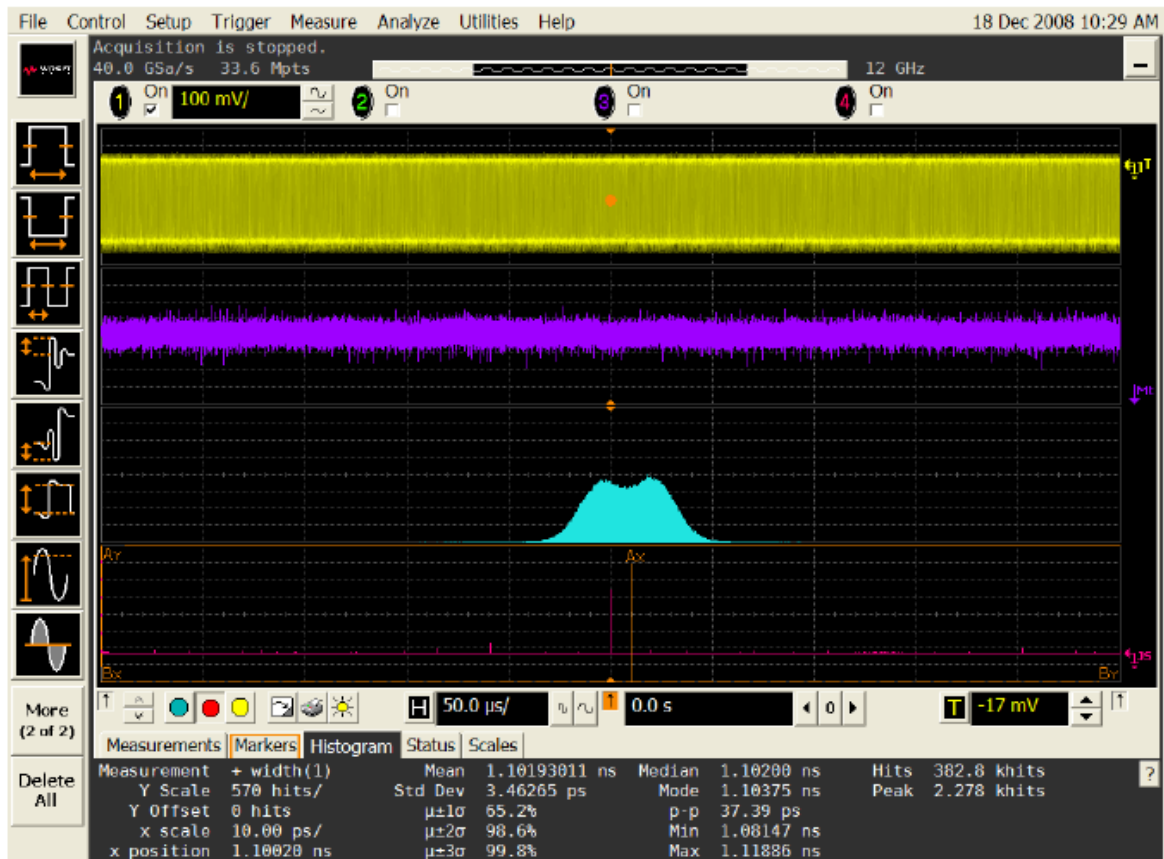

Figure 22.21. Built-in oscilloscope capabilities make it possible to acquire a chirped radar signal with a bimodal PRI and then display a histogram of thousands of pulses

In radar systems that have more than 300 MHz of instantaneous bandwidth above 63 GHz, the Keysight N5280A and N5281A downconverters provide four channels of phase-coherent frequency conversion. With a frequency width of up to 1.5 GHz (N5280A) and frequency range of up to 50 GHz (N5281A), these devices can down convert ultrawideband radar signals into the direct digitizing range of Infiniium series oscilloscopes. When system characterization requires time-correlated measurements between the analog and digital domains, a configuration that includes a Keysight mixed-signal oscilloscope (MSO series) provides an easy, efficient solution.

In the design of radar and EW systems, increasingly complex pulse compression techniques are being deployed to maximize resolution and range or to reduce the likelihood of detection. To help you identify and measure performance, test solutions must deliver high resolution, excellent dynamic range, and wide analysis bandwidth. Keysight's range of COTS solutions include vector signal analysis software, wideband signal analyzers, and multi-channel wideband oscilloscopes. Compared to traditional approaches, these tools provide enhanced ease of use that simplifies the process of producing accurate, repeatable measurement results.

Simplifying the Characterization of Wideband Pulsed Signals

Gaining simplicity through integration

The UXA offers a big step forward in usability by providing factory calibration and operational alignments across the full 1 GHz bandwidth. Integration into the signal analyzer delivers several other benefits: 1 GHz coverage across the full frequency range (3 Hz to 50 GHz); seamless switching between swept, vector, and real-time measurements; and easy operation through the streamlined multi-touch user interface (UI). This combination of capabilities enables informative measurements of pulsed signals in less time (Figure 22.22).

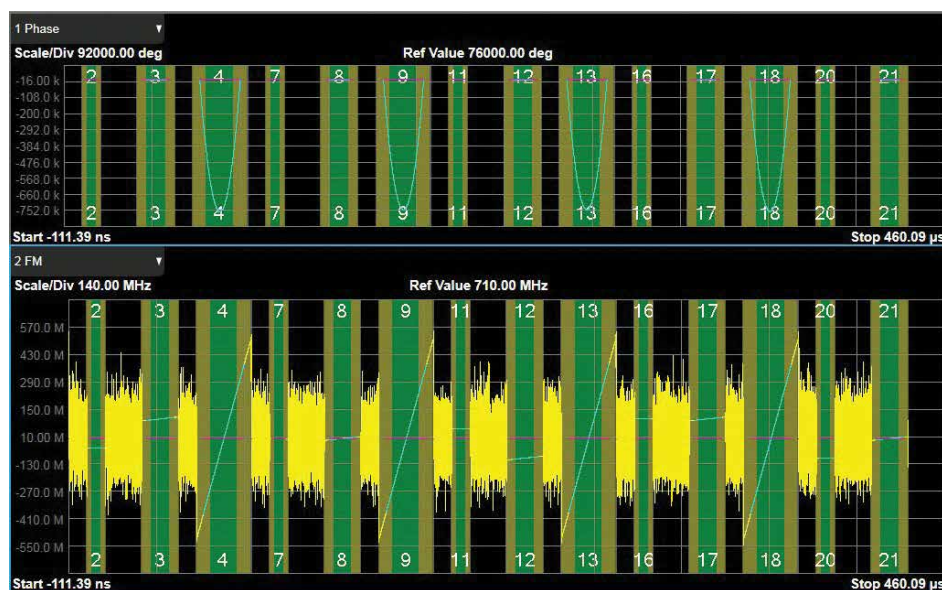

Figure 22.22. The wide integrated bandwidth simplifies measurements of linear FM-modulated pulses.

In contrast, the two-instrument approach (i.e., downconverter and digitizer) requires the user to run a separate calibration with an external source or reconfigure connections to get a flat, usable band or uses a generic correction that provides less accuracy. Additionally, the wideband capability cannot be accessed in low band with the two-instrument approach, limiting the minimum frequency to at least several gigahertz.

Using the broader applicability of wide bandwidth

While another measurement receiver is needed when a signal occupies more bandwidth than the analyzer, it may be less obvious that a wideband analyzer offers benefits in measuring narrower pulsed signals. For example, when measuring pulse rise-times or viewing parameters such as overshoot or droop, the wider analyzer bandwidth offers a faster sample rate, providing more resolution for the measurement. As shown in Figure 22.23, this can be an important aid to understanding the signature of the waveforms.

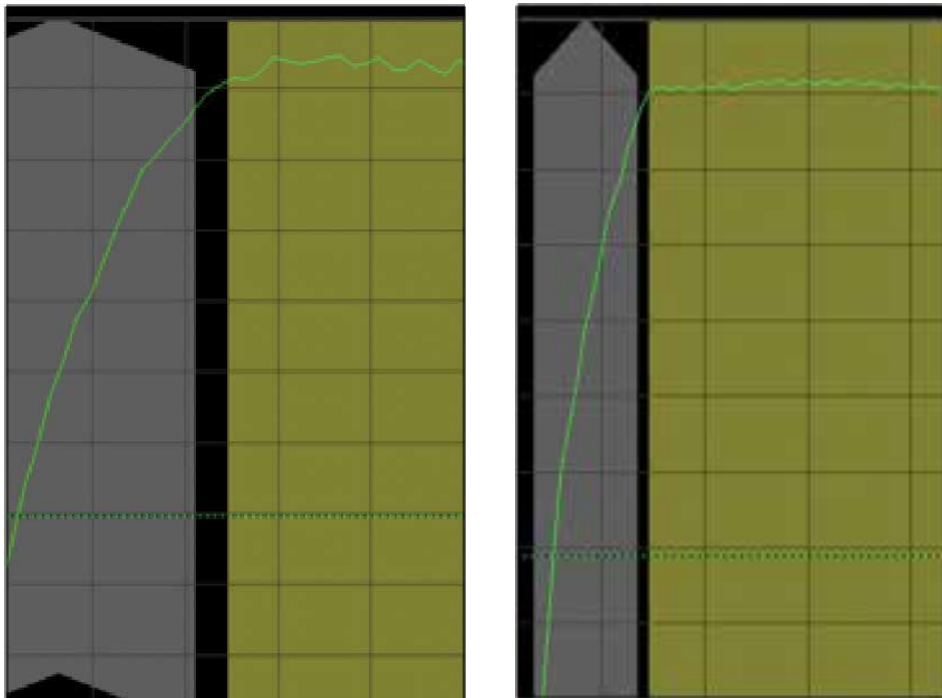

Figure 22.23. The image on the left uses half the sample rate of that on the right. The larger sample rate (or wider bandwidth) shows a clearer envelope of the signal and hence a better representation of the signature of the pulse.

Marker resolution is also improved with a wider bandwidth. Other techniques such as zero-padding can also be used: this will help you see the signal; however, it will still mask the true signature of any fast-moving transient activity such as overshoot.

Finally, it's important to see multiple emitters in any radar or EW signal environment. These emitters likely will also have some intra-pulse modulation and can occur over a wide bandwidth. The UXA can capture multiple emitters across 1 GHz of bandwidth and calculate statistics over a long time. The N9067C embedded pulse application automatically detects and analyzes pulses, providing comprehensive results that enable the full characterization of captured pulses (Figures 22.24).

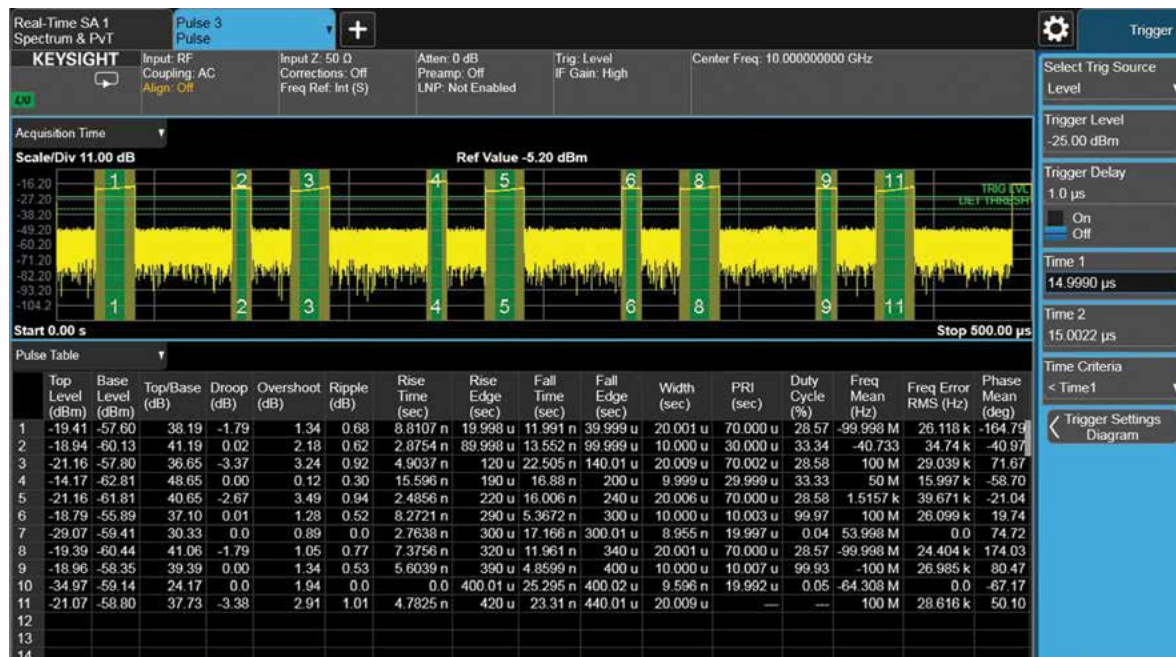

Figure 22.24. The N9067C embedded pulse application can display numerous pulse statistics, simplifying the characterization of dense pulse environments.

Applying the flexibility of a complete solution

Combining these functions into a single instrument enables engineers to scan gigahertz of the spectrum with swept analysis, see dynamic multi-emitter signal activity in real-time, and make detailed wideband pulse measurements—all in less than two touches, saving time whether measuring or troubleshooting (Figure 22.25).

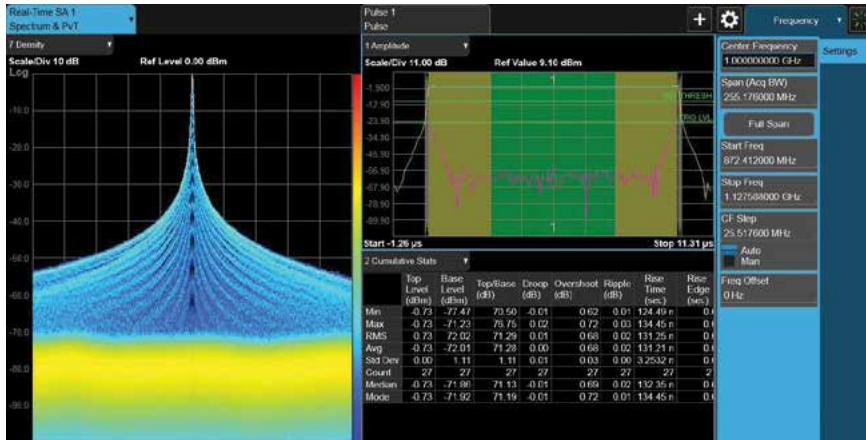

Figure 22.25. The large multi-touch display provides side-by-side views of real-time measurements and tabular pulse metrics, which can be easily exported for post-analysis.

In the UXA, an enhanced 255 MHz bandwidth path co-exists with the 1 GHz wideband path, offering approximately 80 dBc of dynamic range and gap-free RSTA capability. In addition to ensuring that no signal is missed, real-time also provides frequency-mask and time-qualified triggers (Figure 22.26). Users can prune and select specific signals in a dense environment using time, frequency, and amplitude triggering, or any combination of the three.

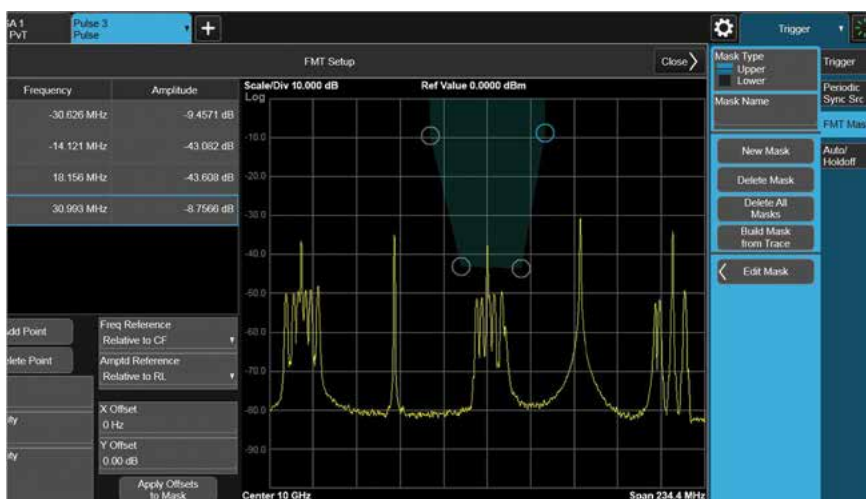

Figure 22.26. Frequency-mask trigger enables frequency-selective analysis with RTSA up to 255 MHz of bandwidth.

The X-Series signal analyzers are the benchmark for accessible performance that puts you closer to the answer by easily linking cause and effect. Across the full spectrum — from CXA to UXA — you'll find the tools you need to design, test, and deliver your next breakthrough.

With wide analysis bandwidth, the flagship UXA delivers wide-open performance and deeper views of elusive and wideband signals. In-depth analysis is made easy with the pulse application software and the 14.1-inch screen with multi-touch UI. With its familiar spectrum-analyzer user experience and capabilities never offered in an integrated instrument, the UXA enables you to see more and take your designs farther.

Chapter 23

Electronic Intelligence

Electronic Intelligence (ELINT) is a subdivision of Electronic Support (ES) within Electronic Warfare (EW). Elint is concerned with the non-cooperative interception of electromagnetic signals that do not carry communications. Such signals cover all categories of radar, beacons and transponders, jammers, missile guidance, radio altimeters, navigation emissions, and identification systems (IFF). This book is primarily focused on testing the serviceability and the efficacy of friendly radar systems and the ability of friendly Electromagnetic Attack (EA) to be effective against radars of other countries.

Efficacy is concerned with effectiveness of a radar's ability to withstand an electromagnetic attack (EA) or to be able to mitigate such an attack. While strictly not a radar signal, identifying and characterizing EA signals is also an essential task. EA encompasses jamming, spoofing (false target generation), and intelligent attack (range gate stealing, eg).

It is important to note that the scope of EA is wider than jammers alone as many new systems are able to use machine intelligence to generate a sophisticated multi-faceted attack with the objective of fooling the radar and not merely jamming it. This new approach to EA is in response to new low-probability of intercept radars, radars that utilise spread spectrum techniques, smart radars using beam management to mitigate EA and multi-static radars.



Spectrum scanning and analysis for both radar signals and EA signals requires similar technical collection techniques and will include:

- Frequency or frequencies of radar or EA signal
- Pulse width and pulse shape
- Pulse repetition frequency
- Power radiated calculated from the radar equation
- Pulse compression codes (barker, costas, etc)
- Frequency spectrum from frequency shift keying
- FMCW characteristics
- Radar or EA beam characteristics
- Frequency agility profile

Technical parameters collected are aligned with signatures and are stored in a Parametric Database. Radar and EA parameters are collected under a Pulse Descriptor Word (PDW) and are assigned to a signature. An integrated collection of Signatures is the basis for an Electronic Order of Battle (EoB). Electronic Support (ES) military units (aircraft, UAVs, satellites, maritime units, and terrestrial army units) revisit signatures periodically to confirm or update. Occasionally new objects are found and after analysis new signatures is added. Some parameters are gathered through other intelligence channels not involving the electromagnetic spectrum.

Important intelligence assets may be subject to continuous monitoring (new or strategic systems, eg). In times of conflict the EOB is central to warfighting in the electromagnetic spectrum, and together with cyber intelligence forms the core element of Cyber & Electromagnetic Activities (CEMA). All friendly electromagnetic assets must comply with the CEMA strategic plan (see Figure 23.1) and hence testing of these assets employing PDWs (signatures) is mandated.

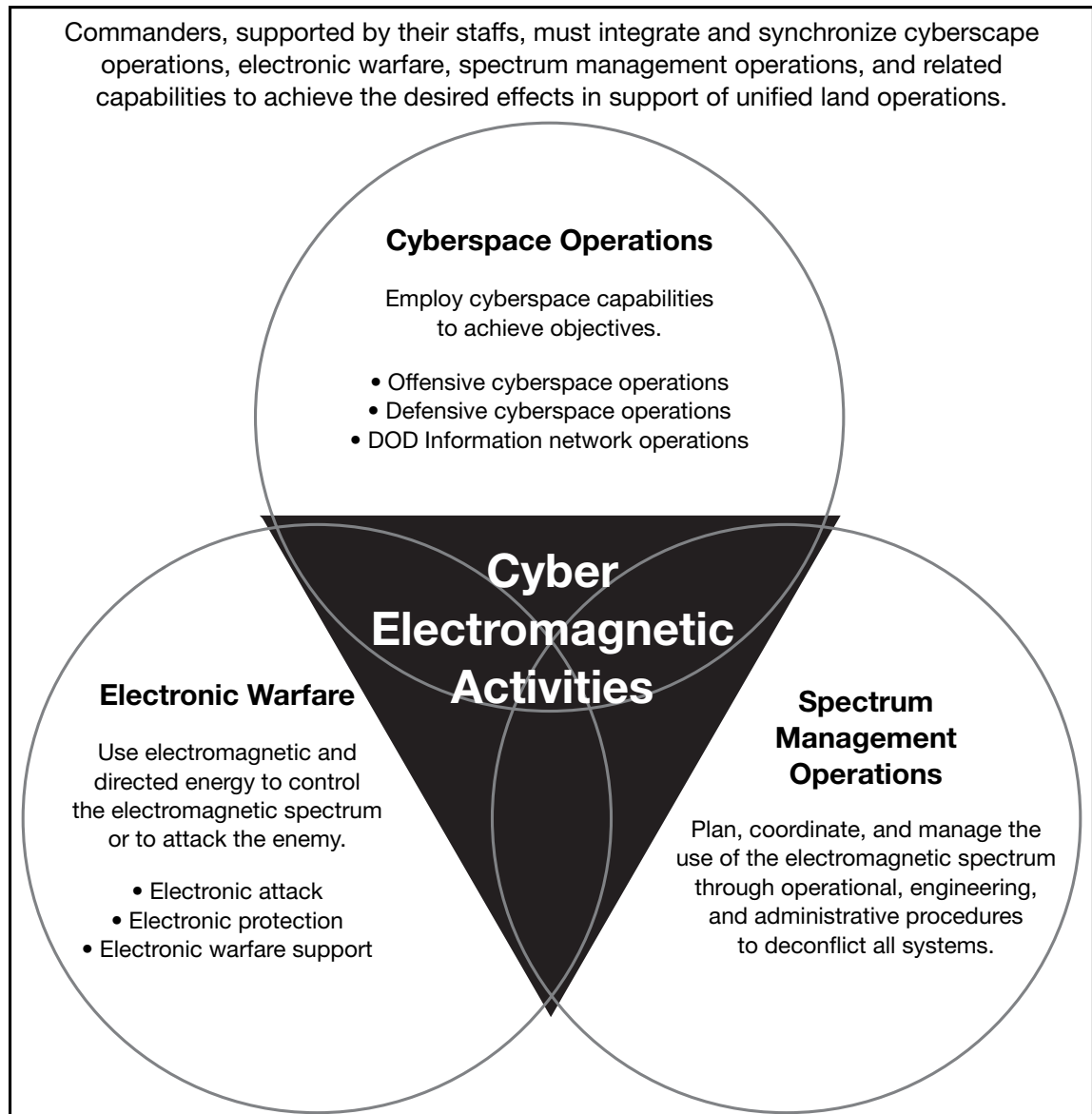

Figure 23.1. CEMA Integration (US Army 2014)

PDWs are used to set up testing environments for both radar and EA. For radar, a model test EA system is formulated and used to test the efficacy and effectiveness of a radar to operate under attack conditions. Figure 23.2 represents a radar test environment for EA scenarios.

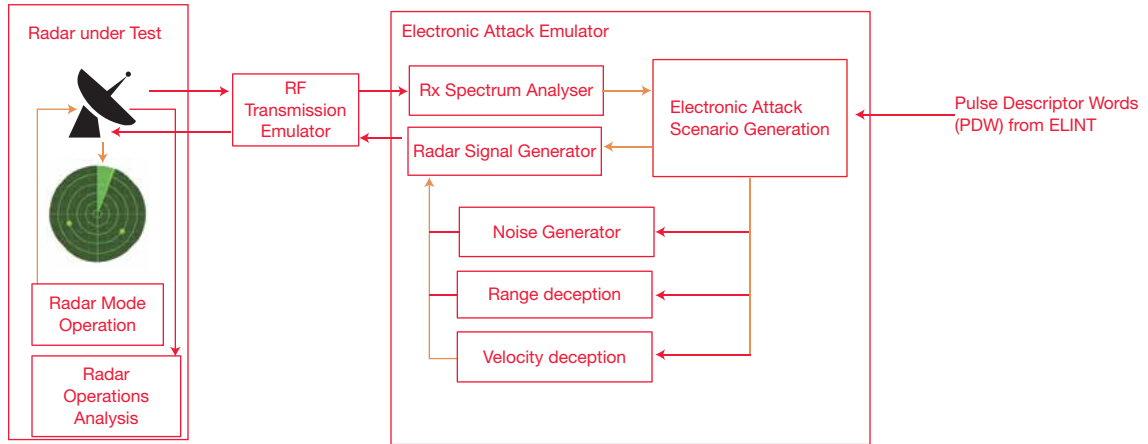

Figure 23.2. Radar test environment under jamming attack

For the effectiveness of a friendly EA asset, a radar test environment is set up using PDWs representing an enemy radar as shown in Figure 23.3.

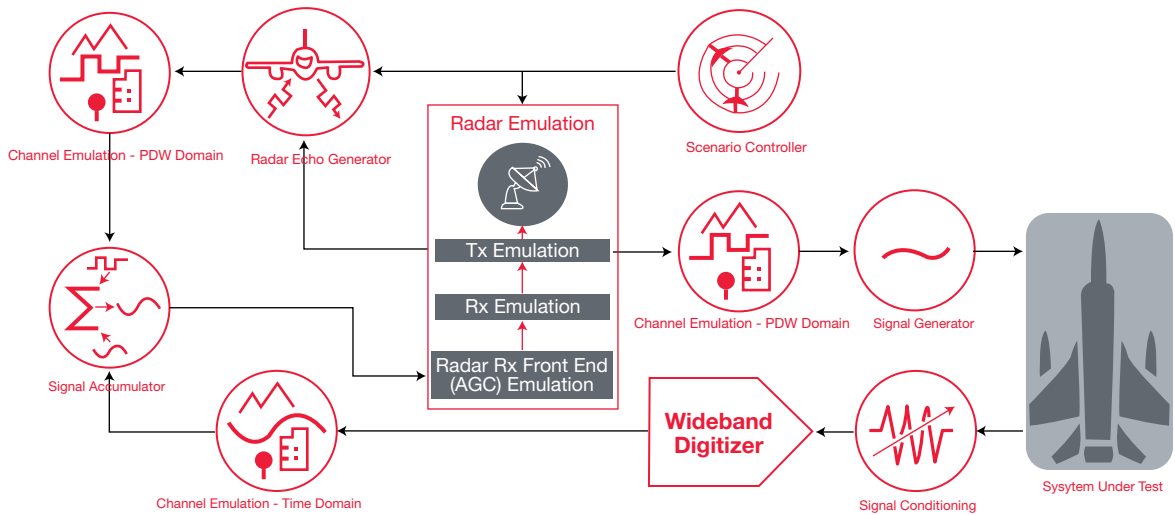

Figure 23.3. EA test environment against enemy radar



Chapter 24 Test System Calibration and Alignment

When generating a realistic scenario capable of testing the performance of a modern SUT, some key concepts must be utilized.

Initially, we need to look at the system calibration process. First, there is the need for system coherence. Next, we need amplitude alignment, phase alignment, and time alignment to emulate angle of attack, also called angle of arrival (AoA). Once we have a coherent system that is amplitude, phase, and time-aligned, we can use the calibrated system to create a realistic emulation of an electronic warfare electromagnetic environment.

Accurately modeling the environment of an electronic warfare scenario requires generating the signals that represent the angle of arrival characteristics of all platforms of interest. To make the emulation of such signals meaningful there must be a very careful creation of amplitude, phase, and timing differences between signals as would be received on multiple antennas of the SUT. The first step in this process is to remove as much error in the signal generation system as possible. This is the primary purpose of calibrating an EW emulator.

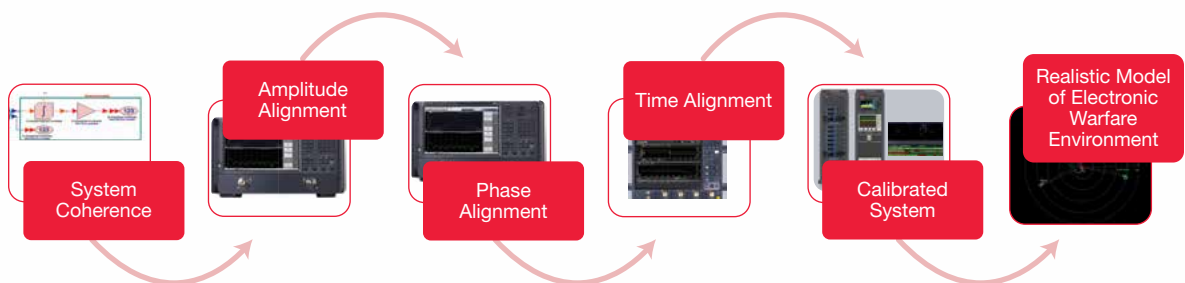

Figure 24.1. System calibration process

Create a Successful Model by Analyzing Considerations

As the threat emulation environment is built up, one of the first considerations needs to be the time-base of the system; specifically, all emitters need to be phase-locked to the same time base. A fully coherent system is critical for a successful model of threat emulation.

Phase coherence is a critical consideration to ensuring success. Two systems are coherent if they have a constant, relative phase at all instances in time. Signals can have phase noise and phase drift and still be coherent. When the phase impediments are common to both signals, they will cancel out and not be present in the relative phase. It can be seen by how coherence is described in the given equation.

$$\rho_{XY} = \frac{E\{(X - \mu_X)(Y - \mu_Y)\}}{\sigma_X \sigma_Y} = \frac{\sigma_{XY}}{\sigma_X \sigma_Y}$$

ρ = coherence

E = expected value operator

μ = average value

σ = std deviation

σ_{XY} = covariance of signal X and signal Y

X = signal X

Y = signal Y

Equation 24.1. Coherence equation

Signals with the coherence of value 1 are fully coherent and those with value 0 are completely non-coherent. When the coherence is somewhere in-between with partial coherence, they are called phase-stable signals.

A second factor, besides needing phase coherence, is having signal alignment. This is when the relative amplitude, phase, and time can be set to near 0, and then adjusted to desired values. Through calibrations, one can know what the relative amplitude, phase, and time are as a starting point. Then, differences in amplitude, phase, and time between the signals can be introduced to emulate accurate AOA characteristics.

Three Dimensions to Calibrate On

1. Amplitude
2. Phase
3. Time

The main dimensions to calibrate on are amplitude, phase and time. This can be done at a single frequency point or across multiple frequencies depending on the SUT design requirements. This removes as much uncertainty from the system as possible.

Amplitude

The difference in the amplitude of two signals in a system defines the amplitude alignment. Some SUTs determine AoA through the amplitude difference in signals received on multiple antennas, so calibrating a threat emulation signal generator for accurate signal amplitudes is important.

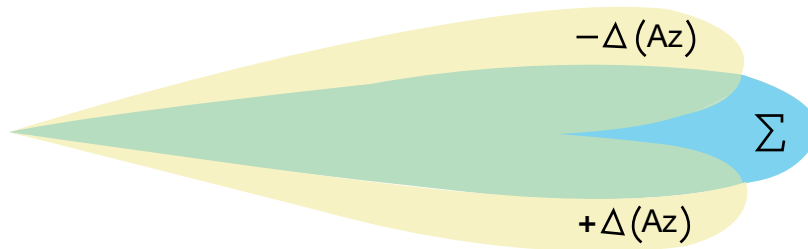

Figure 24.2. Amplitude alignment diagram

$$a(t)_{alignment} = a(t)_{signal\ 1} - a(t)_{signal\ 2}$$

Equation 24.2. Amplitude alignment equation

Phase

The difference in the phase of two signals in a system defines the phase alignment. Once signals are phase aligned, they can be programmed for desired phase shift.

$$\phi(t)_{alignment} = \phi(t)_{signal\ 1} - \phi(t)_{signal\ 2}$$

Equation 24.3. Phase alignment equation

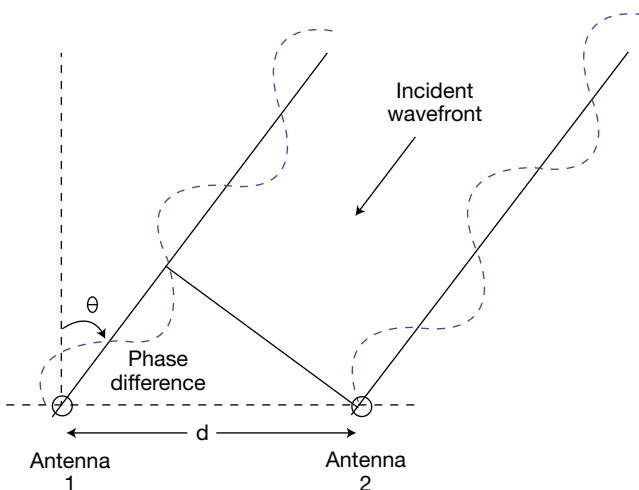

Figure 24.3. Phase alignment diagram

Time

An aligned system is defined by the difference in time between the two pulse envelopes being nearly zero. Desired envelope time shifts to emulate AoA characteristics can be programmed.

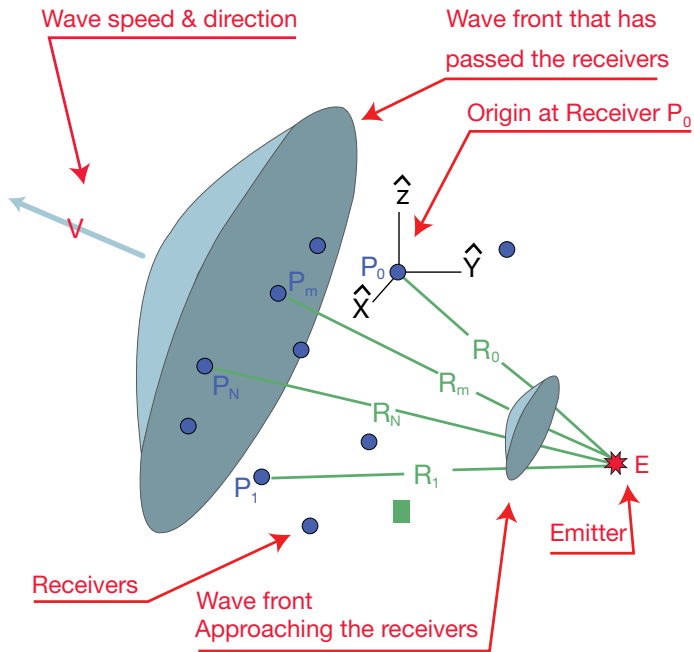

Figure 24.4. Time alignment diagram

$$t_{alignment} = t_{signal\ 1} - t_{signal\ 2}$$

Equation 24.4. Time alignment equation

Once the threat emulator is coherent and the output signals are aligned, RF threat emitters can be accurately emulated. Amplitude, phase, and time alignment in a system allow for accurate calibration between the emulator and the threat, thus ensuring that your threat emulator is accurate. Keysight's 89600 VSA software can be used with Analog and Vector UXGs to create an accurate threat emulator.



Chapter 25 Field Testing, Sustainment, Uptime-Service, and Support

The typical aerospace/defense (A/D) weapons programs can last decades, hence a consistent and reliable performance must be ensured. The sustainment phase of an A/D program makes up most of the program's lifetime cost, up 70% of the total program cost¹. However, it is underappreciated and undervalued when key decisions are made during the early stages of the program².

These milestone decisions made during the early stages incur upfront costs that are relatively high compared to the rest of the program's per-incident costs. However, these key decisions also define the rest of the program, including the long-term costs during the sustainment phase. For example, downtime due to improper planning of test equipment maintenance, especially during production runs, can put a program budget and schedule at high risk. It is therefore vital to consider sustainment challenges and costs in the early stages of the program, and the associated requirements and consequences for program suppliers.

Sustainment Definition and Requirements

How the aero/defense community defines sustainment

The term “sustainment” is used to refer to many different applications, based upon the varying perspectives of roles within the aerospace/defense ecosystem. For example, a government program lead has a different goal for sustaining the program compared to the government contractor’s perspective and goals. Similarly, a test equipment supplier often talks about sustainment concerning long-term support of test equipment hardware. Though supporting test equipment long-term does influence overall program sustainment costs, it is normally not the end user’s main concern. Therefore, it is necessary to consider the end user’s perspective of sustainment in relation to overall program cost and success.

Let’s consider the concept of sustainment according to the government. Reference 3, for example, lists several key goals for sustainment activities. The first is to maximize the chance of mission success through guaranteed availability to meet mission requirements. This is measured through parameters that quantify operational availability and the probability of success of the given mission. Second, unit self-sufficiency during the mission is a goal that is measured by the length of time a unit can maintain self-sufficiency. In this context, self-sufficiency means that a combat unit can operate without external resupply or support for a given period or combat pulse. Self-sufficiency must be balanced by the total number of personnel required for a given combat unit to be successful. The goal is to minimize the number of additional forces dedicated to sustainment while maximizing the length of time a unit can be self-sufficient.



Thus, you can see how sustainment is an essential component of mission success. In addition, expenses due to ongoing operational and maintenance activities are becoming an increasingly larger part of total expenditures. This is shown in Figure 25.1, which depicts total expenditures by category for A/D programs². In the chart, the operations and maintenance category has increased by 10% from the 1980s to the 2000s. It is projected to increase further to 44% of total expenditures by 2029. Personnel expenditures have also increased, likely due in part to increased demand to meet sustainment goals. Unfortunately, although sustainment costs are becoming more significant, it continues to be undervalued and underappreciated during the key decision phases.

Expenditures by category

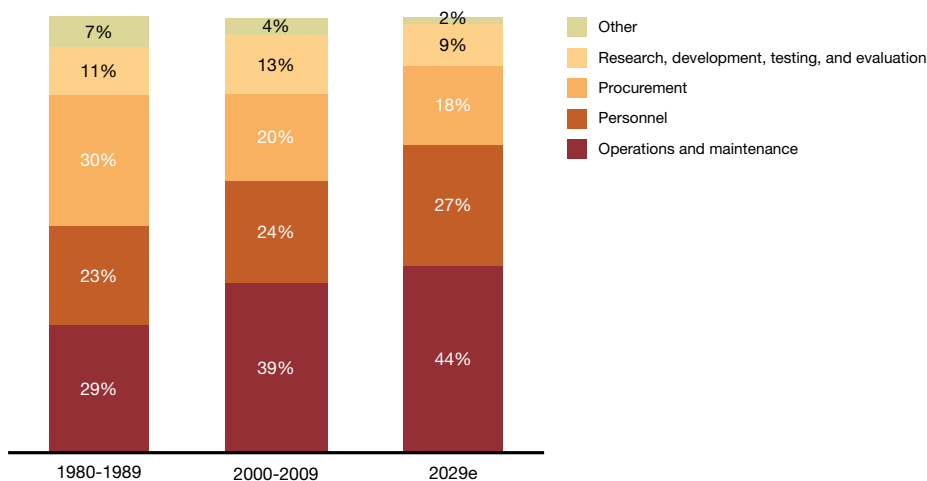

Figure 25.1. Total expenditures by category for A/D programs

Program sustainment and consequences for suppliers

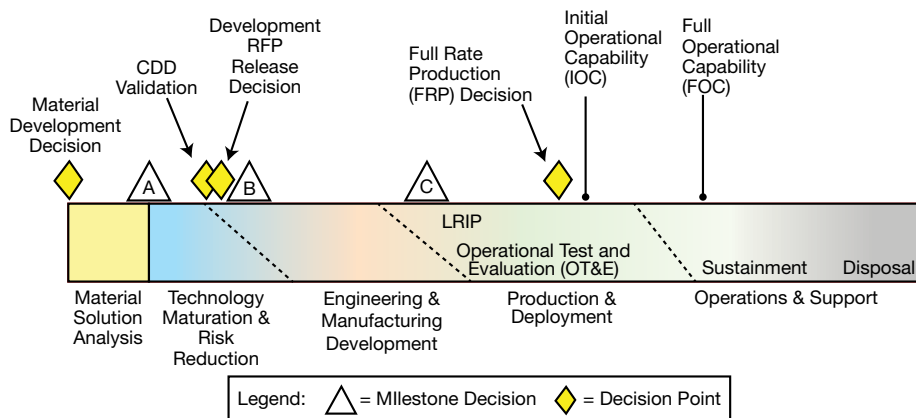

Figure 25.2. Classic program model for a major weapons platform

Now that we have established what the goals are for sustainment and that it is becoming increasingly important to manage sustainment-related expenses, let's consider the program support strategy and the associated consequences for the suppliers of those programs. Figure 25.2 depicts the program

model of a hardware-intensive A/D program such as a major weapons platform⁴. This is taken from the DoDI 5000.02 procedures. Enclosure 6 from the DoDI 5000.02 document highlights the requirements for life-cycle sustainment for such a program. From the first key decision stages, the product support strategy must be developed. This support strategy is the basis for all sustainment efforts to maintain the requirements of the program.

Included in the product support strategy are:

- Sustainment metrics that are continually monitored and managed to minimize program costs and risks to schedule and quality
- An initiative to improve reliability based upon failure modes and critical analysis. Data is captured during the engineering development phase and through systems health info that is available through on-board and off-board technologies
- The ability for competition at the prime and subcontract levels for both system and subsystem levels

The sustainment plan is not fixed. Throughout the lifecycle, the plan performance will be assessed and modified as necessary to reduce cost and risk.

What, then, is the impact on suppliers? Ongoing assessment of a supplier's ability to provide support is part of the overall management of sustainment for the program. It is therefore imperative for the supplier to provide products and product support for the length of the program. It also means that consistent yields are required. In addition, for the supplier to continue to provide the lowest possible cost and remain competitive, predictable costs are required. For example, if the supplier's costs are at risk of increasing over time, this increases prices for long-term programs and reduces the supplier's competitiveness. And finally, to improve sustainment metrics and manage long-term costs, contracts are often re-bid at later program stages. When a supplier can maintain consistent costs and continue to improve efficiency, the chances of winning the re-bid are significantly higher.

Current efforts to support program sustainment

Consider which trends are driving the challenges of sustaining long-term programs and the actions that program contractors are taking to mitigate these challenges. Increasingly, program contractors are focused on outsourcing unnecessary tasks and using more commercial, off-the-shelf (COTS) equipment. This eliminates the need for the contractor to spend time and resources on non-core activities such as tests, which, in turn, enables the contractor to focus on core expertise, driving both innovation and competitiveness. In addition to outsourcing, programs are looking at strategies for reducing total lifecycle costs rather than immediate expenditures. Also, the business model is moving from cost-plus to fixed-price, meaning budget controls are becoming more essential for ensuring program profitability.

Sustainment requirements are addressed by program contractors through:

- Implementing a zero-defect policy for suppliers to ensure uncompromising quality; this means that suppliers' parts must always meet their specifications
- Minimizing downtime to mitigate schedule delays

- Demanding consistent performance and yields while the margins between instrument performance and product specifications continue to decrease

As a result, understanding the limits of test system performance and maintenance is essential for sustainment purposes.

Taking a Total Cost of Sustainment Approach

Key challenges and risks for long-term programs

Based upon the definition of sustainment efforts and requirements, it is possible to identify some of the key risks associated with maintaining long-term programs. First, programs are not always fixed for life. At multiple stages, re-bids put profits and all previous work on the program at risk. Therefore, maximizing the probability of a successful re-bid is essential. Second, maintaining the lowest possible costs ensures profitability. However, it is important not to focus solely on upfront costs. When accounting for long-term program costs, it is important to account for the total cost of sustainment for the life of the program. Third, downtime, planned and unplanned, puts a program budget and schedule at high risk. Having a flexible and dynamic solution for uptime support is therefore essential. On the other hand, unplanned downtime is often a significant issue. Not putting a plan in place, such as acquiring spares, can put the schedule at serious risk. Still, having spares available may not be enough. If spares are not properly maintained and tracked, they may not be usable when needed. Or, even worse, if that spare is not being calibrated at regular intervals, it may appear to solve the immediate challenge of a broken instrument but in fact, be contributing to yield problems.

Finally, support costs become significant when a commercial product is reaching its end of life. Unfortunately, not only are costs higher at the product's end of life due to shortages in parts supplies, but failures tend to occur more often. These risks are more apparent for long-term programs because the lifecycle of most commercial products is shorter than that of most A/D programs.

An underlying issue becomes clear when analyzing the various challenges of sustaining long-term programs: all these risks require time and effort to manage and mitigate. The real goal, then, is not just to mitigate these risks. Instead, it is to eliminate the need to think about them at all. If all these risks are addressed by a third party with the appropriate expertise, then a defense contractor can truly focus on its core proficiencies, and this in turn increases its competitiveness, profitability, and longevity in the market.

Total cost of sustainment example

Consider Figure 25.3, which depicts two different methods for addressing program sustainment and costs. The first is the traditional approach, which will be called the per-incident method. In general, this will save the most money at the beginning of the program because all support costs are paid per incident, and support is typically required less often. In this case, support costs include everything required to maintain the system: repair, calibration, training, etc. This can also include the cost of buying and maintaining spares or periodically paying for onsite services if needed. The other method is equivalent to paying for an annual agreement that covers all required support. A single annual price is charged by the provider of support services, and this price increases each year by only the inflation rate. With a long-term agreement, the service provider can plan, control costs, and ensure a consistent price even when repairs and other services are required more often at the end of the program.

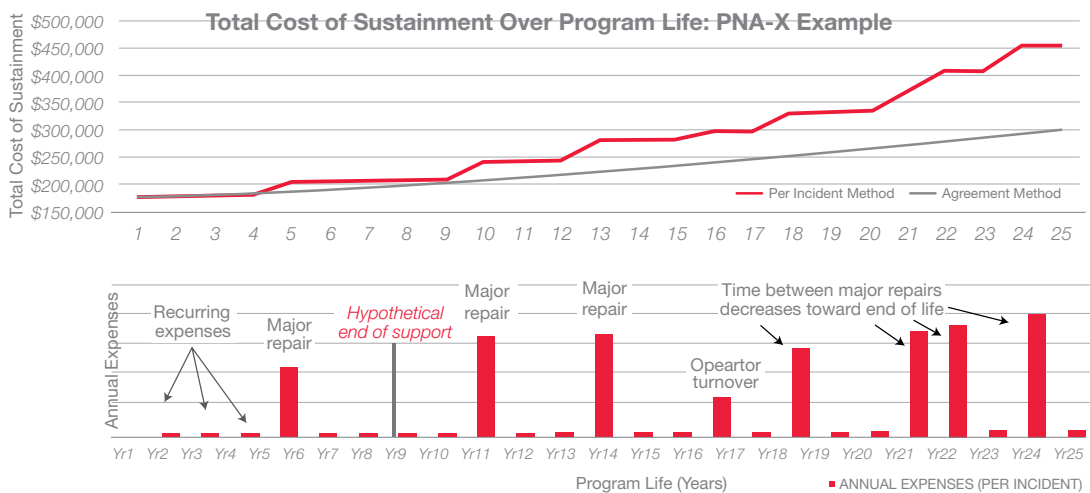

Figure 25.3. Total cost of sustainment example for a network analyzer

The upper plot in Figure 25.3 shows the total cost of sustainment as a cumulative total from years 1 to 25. For simplicity, the figure shows the repair and calibration costs for a Keysight vector network analyzer. The lower plot in Figure 25.3 shows the annual support costs for the per-incident method. The agreement price grows at a 3% inflation rate, so it was not included in the lower plot. Until about year 5, the two methods have similar prices (red and gray lines). But, the cost of each major repair is significantly higher than the agreed price. In general, the agreed price for the entire year can be as much as 70% lower than the per-incident price of one major repair. Therefore, by year 10, the agreement method becomes the lower-cost option. As the program reaches its long-term sustainment phase, the associated equipment has aged and tends to fail more often, decreasing the meantime between major repairs. This creates a major difference in total cost by year 25, the end of the program. In this case, the total cost of sustainment of the agreement method is only 66% of the total cost of paying per incident.

Furthermore, it is important to note that it does not take many failures to justify using the agreement method. To maintain an approximately equal total cost between the methods, no more than two major repairs can occur within 25 years.

A consistent cost is a winner when it comes to achieving the lowest total overall cost. Predictable costs help in other ways, too. For one, knowing the cost to maintain a test system for the entire program life means the true costs are already known if a program must be re-bid. This makes a significant difference compared to the risks of the per-incident method. As insurance, the re-bid is often padded to account for the per-incident costs that may arise. This can significantly reduce the chances of winning the re-bid. This example shows that extending the life of the instrument using the agreement method provides the lowest total cost.

An Innovative Approach to Sustainment

Ensuring predictable costs for long-term support

Consider a test system made up of many elements, including instruments, components, signal routing, and switching elements, and control and computation elements such as CPUs, etc. This normally includes elements from many manufacturers, as well as custom-designed components from third-parties or by the program contractor itself. Every element of the system will be at a different point in its lifecycle. In addition, each element's lifecycle may be shorter or longer based upon the type of element and its associated demand cycle, parts availability, industry's pace of evolution, etc. One approach used by OEMs that is normally expensive and usually cost prohibitive is to look at expected failure rates for all components in the system and stockpile enough spares to cover the entire life of the program. This creates an enormous cost upfront and does not consider the evolving failure rates and requirements of the program itself.

An alternative approach is possible and would dramatically reduce upfront costs while managing ongoing expenses appropriately. Using this approach, the program contractor partners with the OEM to plan for long-term support. An end-user who chooses to adopt this approach can achieve predictable sustainment costs because the OEM using this planning approach can ensure consistent prices. This partnering approach utilizes a key role that must be created by the OEM called the "project success manager." The project success manager is responsible for ensuring that support is available, provided only as needed, and delivered at the lowest possible cost, which translates to a low, predictable cost for the program contractor.

There are four key aspects of this approach that are implemented by the project success manager. First, for system elements that are manufactured by the OEM service provider and have not been discontinued yet, the project success manager works with product planners to ensure that parts are available throughout the life of the program. Product planners then make lifetime buys when necessary to ensure that parts are available for standard support purposes and any existing sustainment contracts. Second, the project success manager continually audits the system bill of materials to determine when obsolescence is imminent and secures the appropriate parts or spares. For example, a CPU often has a much shorter lifecycle than a typical A/D program. The project success manager must ensure that enough spare CPUs are available, which are compatible with the system and meet program requirements.

As a system element approaches obsolescence, the correct approach for managing parts varies based upon the type of component. In many cases, it is necessary to stockpile parts accordingly. The availability of parts depends heavily upon where the system element is in its lifecycle, the manufacturer's strategy for supporting elements, and the overall demand for that element's parts and components. The third task implemented by the project success manager is to ensure that each element has enough supply of parts using any means available. A system element that is past its obsolescence period, for example, may be only available at a marketplace for used equipment. Or, due to the risk of counterfeit parts, there may not be any parts available from trustworthy sources. In this case, utilizing in-house expertise in component-level repairs can ensure parts are available for decades beyond obsolescence.

The final aspect of this novel approach for sustaining test systems is to continually plan, especially earlier in the program's lifecycle. The project success manager, therefore, ensures that predictable, consistent costs for support are achieved. This translates to an overall predictable cost of sustainment for program contractors.

When to plan for sustainment?

When is the best time to start planning for sustainment? As discussed, costs can be reduced when appropriate planning occurs in advance of the product obsolescence period. However, in most cases, it is possible to still achieve significant value and savings no matter where the program is in the cycle. At least part of the issue is mitigated by the fact that few if any of the products are on the same cycle. Many of the newest products will likely be free of parts shortages for the majority of the program. For any products built with parts that may be in short supply in the near term, possible solutions include a decision to use a combination of used equipment, parts stockpiling, and component-level repair capabilities.

Consider Figure 25.4, which depicts the tradeoff between the value and cost of a sustainment solution based upon which program phase is currently employed. At a high level, this graphic depicts the inverse relationship. The earlier that you plan for sustainment, the more options there are available to achieve the lowest cost. One reason for this, as discussed, is the number of options available to acquire or supply stockpiles of parts. In addition, besides parts supply, sustainment and test costs can be significantly reduced through a combination of services that are tailored according to the program phase and goals.

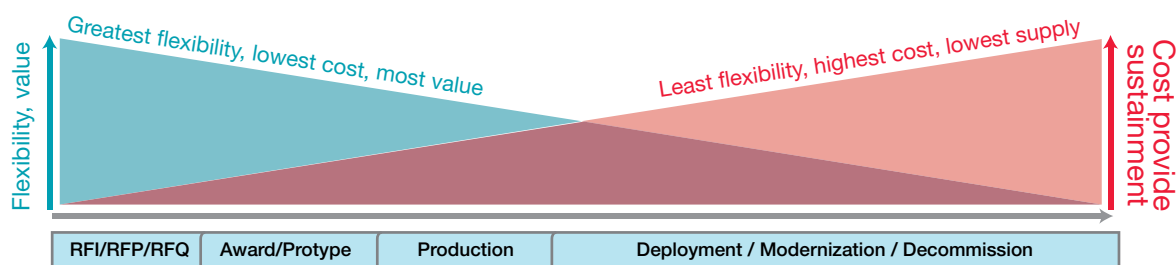

Figure 25.4. Tradeoff between value and cost based upon program phase

For example, in the definition phase, consulting to help design the test system and improve test processes reduces long-term costs. Later in the lifecycle, there is still time to do significant planning. Onsite services can be utilized, such as providing a dedicated expert to ensure maximum uptime when it is needed and for critical systems that need it most. Better management of assets through available programs and tools can help identify utilization and health of instruments, producing insights into reducing capital expenditures, operational expenditures, or both. By performing analysis regarding the timing of obsolescence, actionable insights can be used to determine which instruments are candidates for a technology refresh and the best timing for that process.

Comprehensive Uptime Program

Planned and unplanned downtime must be addressed in addition to long-term support to minimize ongoing costs. It is important to understand the cost and benefit tradeoffs of any downtime mitigation or uptime program, from a simple spare strategy to a comprehensive partnership with an OEM. Also, note that the optimal uptime strategy may evolve as the program moves through its lifecycle stages.

To better understand the cost versus benefit tradeoff, consider the cost of downtime according to the current program stage. For example, in the earlier development and prototyping stage, downtime is more manageable and may be mitigated through a spare program or even a return-to-OEM strategy with dedicated turn-around-times. On the other hand, when a system is getting used regularly to identify and verify new threats, the cost of downtime is likely much higher. This is especially the case when lives are at stake. The difference between sending individual instruments away to be calibrated and an on-site approach can reduce downtime from months to days, or even hours. Check with the original equipment manufacturer (OEM) on available solution-level services that reduce downtime. Examples could include a customized solution of on-site repair and calibration services, dedicated loaners for any instruments that cannot be serviced on-site, and guaranteed response times for on-site service calls.

Consider the following case study that highlights how partnering with the hardware solution provider can mitigate program and schedule risks while providing consistent access to the system. In this case study, the defense contractor needed to increase its system output but did not have the people, equipment, or floor space to meet the requirements. Current system uptime was less than 70% and was considered acceptable based upon uptime measured on other systems and programs. However, by partnering with the OEM system provider on a comprehensive uptime program, the contractor achieved consistently greater than 90% uptime. This additional uptime translated to greater capacity, which allowed the contractor to achieve the increased production targets without acquiring more facilities or floor space. The comprehensive program consisted of OEM expert personnel embedded in the contractor's environment with a working set of spares and parts to provide all required services inside the secure environment. All moving of parts and equipment in and out of the secure environment was performed independently, and therefore this did not impact the contractor's system uptime.

Of course, it is important to understand, based upon program requirements and system usage, the impact to cost and schedule that any of these solutions will have relative to the cost of each potential solution. In the case study, the defense contractor achieved such a large benefit with increased capacity that it far outweighed the cost of embedded OEM personnel dedicated to servicing the contractor's systems.

Technical Support

Technical support is a key component of the support plan for any test system. Understanding the use of the system, or perhaps even more importantly, identifying whatever is causing unexpected issues with the test system is an absolute necessity to most efficiently utilize the time spent on the system and increase overall capacity. This ensures schedules are met and system use is maximized. Technical support at the system level can take on many forms, whether remote or on-site. Based upon the program stage and requirements, it is important to consider the best method for receiving regular technical support, as well as the process that is used in the event of a support issue. For example, while on-site technical support may be especially useful in the beginning after the system has first been delivered, remote support may be sufficient once the initial learning phase is completed. While a remote expert would not be able to see the system, he or she should know about the system architecture and would still be able to troubleshoot issues remotely. In addition, any required service such as a repair could be quickly identified and ordered remotely.

Sustainment is a major contributor to the overall program cost, and in many cases is the leading contributor. This has consequences. For example, long-term supportability is required. Also, it is important to maintain predictable costs and utilize cost-management techniques (e.g., improve efficiency).

Not only is sustainment a leading contributor to the program cost, but most of these costs are also locked in by decisions made during the development phase. As shown, managing risk through a planned approach to sustainment can ensure predictability and lower overall costs versus addressing and managing the issues when they arise. Predictable costs ensure maximum probability of success when re-bidding contracts and maximum probability of total program profitability. They also remove the risk of high-cost per-incident support events.

Unfortunately, it has been common to accept the risk of managing issues when they arise. This may seem to be the lowest-cost option, especially at the beginning of the program when support costs are usually low. However, this is not the best long-term option. The costs can be very high, and there is no way to predict the magnitude or timing of those costs as the program ages if no planning has been done earlier.

Predictable and consistent costs are achieved by partnering with an OEM that is committed to delivering the right level of support throughout the lifecycle. The innovative approach to sustainment solutions discussed ensures test systems are operational and maintained long-term, provides the right level of uptime support, and minimizes total sustainment costs. Additionally, while incorporating sustainment solutions earlier in the program enables greater value and cost savings long-term, a customized sustainment solution can be created for any phase of the program and set of requirements. One example of this is an evolving uptime solution tailored to the given program stage and requirements.

Ultimately, by leveraging a customized solution for sustainment, the program contractor eliminates the excess time and resources previously required and can focus on true core competencies and differentiators. Thus, profits are maximized, a schedule is maintained, and long-term success is achieved.

References

1. D. Gouré, “Pentagon Plan To Manage F-35 Sustainment Is A Good Move,” [lexingtoninstitute.org](https://www.lexingtoninstitute.org), Jun. 1, 2015. [Online]. Available: <https://www.lexingtoninstitute.org/pentagon-plan-to-manage-f-35-sustainment-is-a-good-move/>. [Accessed: Feb. 12, 2019].
2. S. Hurt, “Three Ways the U.S. Department of Defense Can Achieve Its Sustainment Objectives in Challenging Times,” [atkearney.com](https://www.atkearney.com/), Feb., 2013. [Online]. Available: <https://www.atkearney.com/aerospacedefense/article/?a/three-ways-the-u-s-department-of-defense-canachieve-its-sustainment-objectives-in-challenging-times>. [Accessed: Feb.15, 2019].
3. E. Peltz, “Equipment Sustainment Requirements for the Transforming Army,” [rand.org](https://www.rand.org), 2003. [Online]. Available: https://www.rand.org/pubs/monograph_reports/MR1577.html. [Accessed: Jan. 18, 2019].
4. Executive Services Directorate, “Department of Defense Instruction 5000.02,” Executive Services Directorate, Aug. 10, 2017. [Online]. Available: https://www.esd.whs.mil/Portals/54/Documents/DD/issuances/dodi/500002_dodi_2015.pdf. [Accessed: Feb. 2, 2019].

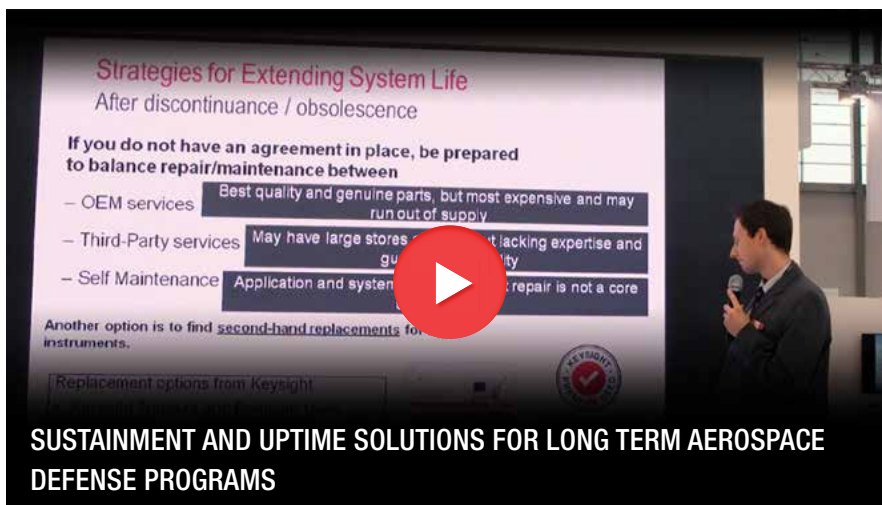

<https://www.keysight.com/see/radar-ew-system-test>



Chapter 26 Software Testing for Radar & Electronic Warfare Systems

In addition to testing the hardware components of radar and electronic warfare systems, growing importance is attached to testing the software of these systems. This chapter will highlight some of the developments and emergent best practices of software testing.

Software Test Automation and the Development Lifecycle

Software test automation is a key component of DevOps. Recent years have seen a push towards DevOps across IT systems in both private industry and national defense. DevOps refers to the set of practices that automate processes between software development and operations. The goal of DevOps is to build, test, and iteratively release more reliable software in a faster manner, often involving and complementing Agile methods.

Emphasizing the importance of security, the concept of DevOps is extended to DevSecOps. The US Air Force's Office of the Chief Software Officer defines this as "the software automated tools, services, and standards that enable programs to develop, secure, deploy, and operate applications in a secure, flexible, and interoperable fashion." Among the benefits of the adoption of DevSecOps are shortened release cycles, higher-quality releases that can incorporate continuous feedback from real end-users, and the automation of testing and security.

Software Test Automation is a Requirement of DoD Projects

Traditionally, software testing has been conducted through the writing and execution of test scripts. Automated testing allows teams to automate repetitive, rule-based tasks to accelerate testing and widen test coverage. In October 2020, the US Department of Defense published its latest guidelines on software test automation in DoD Instruction 5000.87, Operation of the Software Acquisition Pathway. The Instruction sets out the policy and procedures for "efficient and effective acquisition, development, integration, and timely delivery of secure software."

The iterative development approach encapsulated by the phrase "Software is never done" suggests a constant cycle of planning, coding, building, and testing. More specifically, continuous testing is a requirement of the execution phase of software development, with DoDI 5000.87 indicating that whichever software development methodology is being used, it must "incorporate continuous testing and evaluation, resiliency, and cybersecurity, with maximum possible automation, as persistent requirements ... throughout the entire lifecycle."



Choosing Appropriate Testing Infrastructure

There are several open source and commercial tools available to automate software testing. However, because of the unique requirements of radar systems, there are some qualities and capabilities to consider when assessing software test automation solutions. Keep the following in mind when evaluating solutions:

- Testing should cover the user journeys and interactions between the users and various devices in radar systems, not just individual software components in isolation.
- There is often a diverse set of interfaces to be tested, from the command line to graphical user interfaces (GUIs) like touch screens.
- As such, it is important to have the ability to test multiple endpoints built on entirely different technologies and programming languages.
- Tests should be able to be conducted in a non-invasive manner, i.e., without access to source code.
- Testing solutions should exist on-premises and be operable without phoning home.

Testing requirements are not limited to individual systems, components, or pieces of software themselves, but rather the supersystems of connected devices and software covering multiple endpoints. As such, principles and practices from software test automation can be applied in the context of radar systems and electronic warfare. The sheer diversity of devices and software means that any software test automation solution must be sufficiently adaptable. This goes way beyond simple bug testing. Interactions that real users can do must also be tested, such as using a touch screen, transferring data across a network, or reaching into a database.

Creating a Testing Plan

Various types of testing should be included in your software testing plan:

- **Regression testing** — When certain components of the system are upgraded, will the previously developed and tested software still work in the desired manner?
- **Usability testing** — Can operators of radar systems access and use the features needed to fully take advantage of the systems' capabilities?
- **Performance testing** — It's important to replicate real-world conditions to ensure that the systems can perform in the desired manner. Tests should look at peak conditions, operating capacity, application and device integration, response time, and loading speed.
- **Functionality testing** — This covers testing system functionality, user workflows, and accessibility considerations.
- **Integration testing** — Does the software interact with or draw information from other systems? If so, these integrations need to be tested.
- **Security testing** — The software needs to stand up to the strict security standards and protocols demanded by defense agencies.
- **Exploratory testing** — The testing solution should be able to proactively track down and identify bugs. Software test automation can be augmented by artificially intelligent bug detection that will flag up errors that human testers will miss.

Given the mission-critical nature of software testing, it's important to build a coherent and robust software testing plan. Consider the wider strategic goals of your radar systems, how users will interact with these systems, and what human and technological resources you will need to carry out your testing plan.

AI as an Accelerator for Software Test Automation

Advances in artificial intelligence (AI) have direct consequences for testing the software of radar and electronic warfare systems. AI can augment many areas of software testing: regression, usability, performance, functional, integration, security, and exploratory.

In short, AI allows software interfaces to be interpreted and intelligently interacted within the absence of direct human supervision or input. AI can then explore the various permutations of actions possible in the interface, autonomously generating novel user journeys that may unearth otherwise unknown bugs and defects. This exploration of an application or software system is called exploratory testing, a discipline that has traditionally been heavily reliant on manual human testers. AI-augmented exploratory testing can be a uniquely effective method to “identify system capabilities, limitations, and deficiencies,” a requirement of DoDI 5000.89, ‘Test and Evaluation.’

Software test automation benefits from AI by first interpreting the text and visual elements on the screen via optical character recognition (OCR) and computer vision, respectively. This requires the AI to apprehend and interpret various screen elements, whether they are input controls (e.g. buttons or text fields), navigational components (e.g. breadcrumbs or icons), informational components (e.g. notifications or message boxes), containers, or other objects. Once a model of the application or system under test has been constructed, intelligent agents (sometimes referred to as ‘bots’) will navigate the application and perform actions.

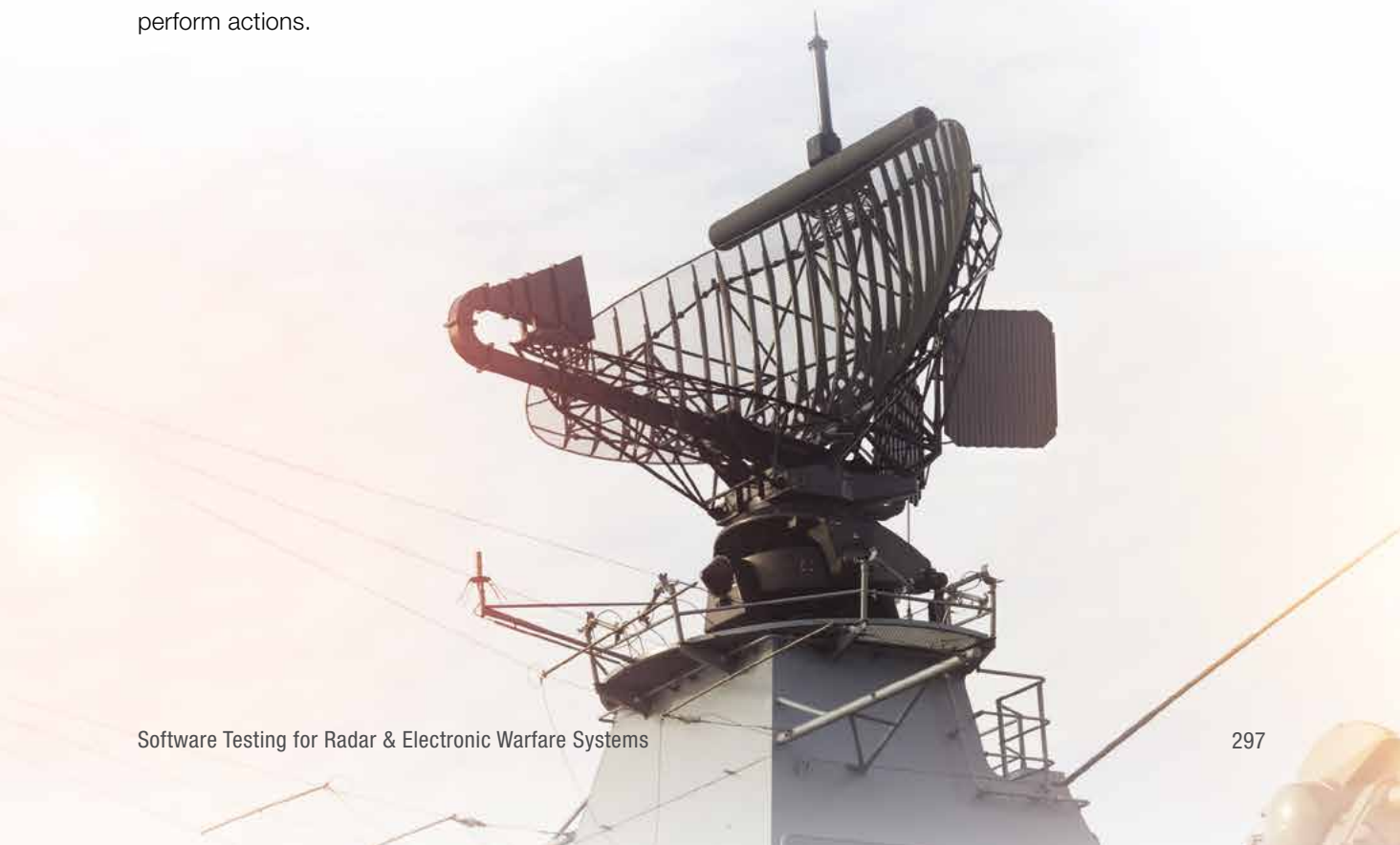

The training set that allows the AI to intelligently navigate the software interface can be provided by two general sources:

- Exploratory testing models learned from millions of user journeys across all types of software and devices.
- User behavior observed from interaction with the specific application to be tested. The application can be instrumented and event-level data from real usage is collected and used to train the AI.

AI is also helpful for the visual validation of software. Code or object-level testing tools can provide a certain level of confidence that data and objects have loaded properly. However, certainty can only be achieved if visual validation tools are used to ensure that the elements onscreen reflect the intended outcomes. In other words, computer vision can be used to verify that the user interface is behaving expectedly. When visual validation fails, this indicates to development teams that there is some behavioral quirk in the software that needs to be addressed.

Intelligent agents can also be used to stress test systems for performance and load testing. Virtual users can flood an application, with visual validation tools used to ascertain the impact on the user experience of peak loads.

AI has a great deal to offer software teams in the radar and electronic warfare space. By augmenting existing testing methods through AI and automation, developers can achieve a much greater understanding of the true performance, behavior, and utility of their software in real-world scenarios. Ultimately, this reduces the amount of 'unknown unknowns' for the modern warfighter.



<https://www.keysight.com/see/radar-ew-system-test>

Chapter 27

New Age Requirements of Cyber Security

Connected networks such as air defense and air traffic control are vulnerable to cyber-attacks. Search online and you will find examples of hacking and spoofing that disrupted defense networks rendering them temporarily ineffective, allowing adversaries to gain tactical advantage. Not all hackers have such perilous intent – their motivation may be espionage or simply penetrating a secure system for “fun” as a test of skills and wits. With modern systems becoming increasingly connected, and with regular software updates required for adaptive systems and machine learning, securing your operations against cyber-attacks has never been more important.



Evaluating Security Effectiveness

One of the challenges of assessing security effectiveness is that it has been hard to quantify in the past. Your security was either effective, meaning that you had not been breached, was not effective because you had been breached, or worse, you thought it was effective simply because you didn't know you had been breached. Security teams have focused correctly on the prevention and detection of attackers. Malware relies on network communication to download instructions and transmit sensitive data. Actively blocking network probes, phishing clicks, and all traffic to and from untrusted countries dramatically reduces your exposure. With those technologies and processes in place, it has become critical to obtain a repeatable and ongoing measurement of your security posture.

SecOps Impact

Breach and attack simulation expose the gaps in your security environment, but it also helps you fix the problems and then re-audit to confidently know your work has made your security stronger. For too long, security professionals have often had to simply guess that what they did on a Monday helped the company's security on Friday. With breach and attack simulation, that is no longer a question. Now you know the impact of your time and resources, allowing you to accurately measure security operations effectiveness and costs.

Enabling Breach and Attack Simulation

Being aware of today's threat landscape is vital to identify the weaknesses in your environment. Threat intelligence comes in a variety of flavors and nearly every security product has a "threat intel" feed that allows it to understand what to defend against. The end goal of threat intelligence is to provide knowledge that allows you and your tools to make the right decision. Traditionally, threat intelligence has been used proactively to either stop a known bad actor, perform incident response, or breach forensics. Security teams are beginning to realize that the same knowledge about attack exploits and techniques can be used proactively to harden security before an attack. To be proactive in using threat intel it is critical to also have a long history of knowledge alongside the data, as well as expertise to understand the latest threats.

A defense organization will be genuinely assured in its security posture only after having it tested. Being "tested" is not a euphemism for suffering a breach. Being tested means deploying a breach and attack simulation solution to continuously create security audits. Continuous breach simulation identifies weak spots and misconfigurations to be more closely monitored. With breach and attack simulation, an organization gains first-hand insight into how the attack will succeed — without opening the door to their adversaries.

Additional Reading

[Breach & Attack Simulation For Dummies, Keysight Technologies Special Edition](#)

Section 6

Gain Confidence, Achieve Realism





Chapter 28

Achieve Realism and Accuracy in EM Spectrum Operations

Using a scalable, high-performance commercial off-the-shelf (COTS) testing approach, you can create threat simulations and analysis systems that keep pace with the modern electronic warfare environment.

The electromagnetic (EM) spectrum environment is evolving with increasing speed and complexity. New threats emerge constantly, driving the need for electronic warfare (EW) systems that can accurately identify and neutralize radar threats. Often, these responses include adaptive and cognitive countermeasures. To provide the accuracy required for system performance, EW tests and evaluations must adapt through significant advances.

This challenge faces increased pressure with high-fidelity complex emitters, as there is a need to simulate and analyze high-density environments. As the EW threat environment continues to evolve, confidence and reliability in EW system validation and verification requires modernization and improvements in the test and evaluation process. To ensure consistency throughout the development, testing, and deployment of EW systems, you must identify when or where an error occurred. With Keysight's full range of COTS building blocks, you can test and evaluate from digital modeling in research and development through system integration, flight tests, and fully operational systems.

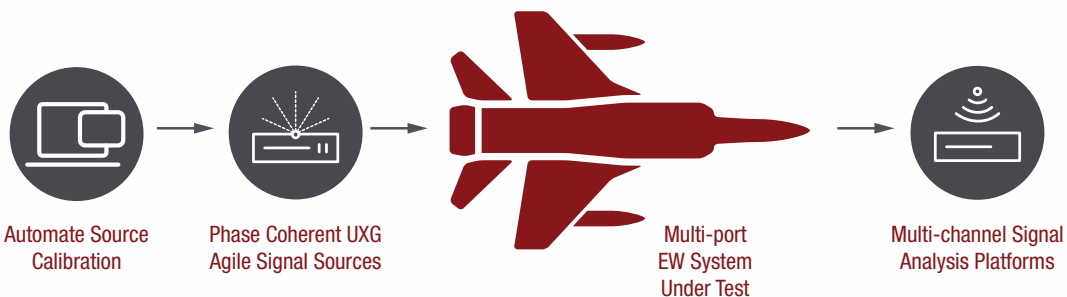

Simulate EW Systems Under Test (SUT)

By performing digital modeling before hardware implementation of an EW system under test (SUT), you reduce the risk of both development time and high program costs. Keysight's SystemVue radar modeling library helps to verify and analyze EW system processing, algorithms, and countermeasures by creating digital models of the system and running simulations with environmental effects including multi-path reflections, interference, jamming, targets, and clutter.

Using a COTS range of test and measurement equipment provides testing flexibility and adaptability as the system moves from a digital model into hardware prototypes during hardware-in-the-loop (HIL) testing. Choose from a range of arbitrary waveform generators and agile vector signal generators for signal generation. You have a choice of oscilloscopes or digitizers for signal analysis. Using SystemVue as a platform, you can control the hardware test setup.

- Analyze entire system including dynamic flight path, multi-emitters, jamming, and interferers
- Model environment, RF hardware, antenna, and phased array effects
- Reduce cost and time of field flight tests through simulation

SystemVue

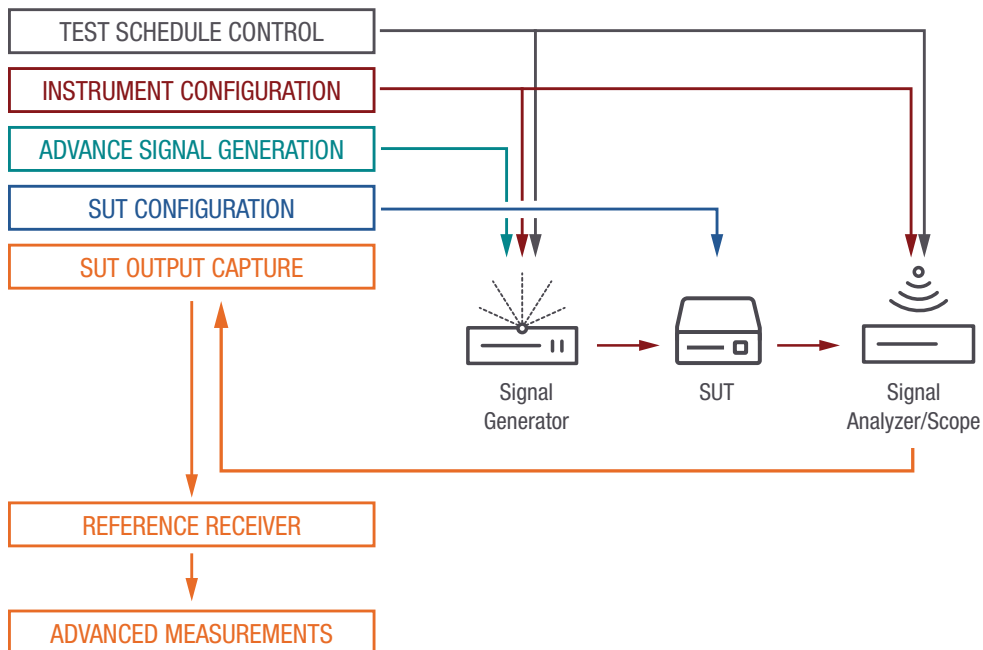

Get Closer to Reality

With the rapid evolution in the EM spectrum environment, you need to quickly adapt to new, complex threats on an ongoing basis. Scalable signal simulation enables you to create complex, high pulse density EW scenarios and simulate Angle of Arrival (AoA) and kinematics (moving platforms) simultaneously. Keysight's capability centers on multiple coherent N5193A/94A UXG agile signal generators.

With an agile signal generator that can switch frequency and settle amplitude in the hundreds of nanoseconds at different frequencies, you can accurately simulate radar threats and targets. When looking for a solution to simulate your RF environment, make sure the product's internal modulation bandwidth is sufficient to cover your threat frequencies of interest. Our solution combines UXGs, calibration hardware and software, and application software for pre-scripted or dynamic threat generation scenarios. The application software has been configured to simulate an electronic battlefield with thousands of emitters.

Pulse Descriptor Word Based Operation

- 1Gb LAN or SSD streaming to > 1Mpps
- 10 GB LAN streaming to > 10Mpps

Applies User RF Corrections to Pulse Descriptor Word Data

- To system under test input port



Reports Pulse Counts

- Received, played, expired, or collided

EW System Under Test

The UXG agile signal generator's ability to fast frequency hop with phase continuity and repeatability makes it an ideal source to efficiently simulate complex threat environments across the signal generator's full 40 GHz range:

- Multiple pulse-Doppler radars at different frequencies while maintaining the original phase as the signal generator hops from one emitter frequency to another
- EW scenarios with thousands of radar threat-emitters and millions of pulses per second with unique antenna scans
- IQ custom complex modulation on pulse with the UXG Vector Adapter including linear and nonlinear frequency modulated chirps over a 20 GHz range
- Scaling up the number of UXGs to increase pulse density while enabling pulse-on-pulse simulations or multi-port angle of arrival (AoA) simulations
- AoA simulations with multiple UXGs and staggering identical pulses played out of different ports (different UXGs) in time, phase, amplitude, or all three

Timesaving approaches to PDW simulations

The UXG's flexible architecture and legacy threat library import capability offer a replacement for current RF sources or integration into new threat simulators. Easily use existing Pulse Descriptor Word (PDW) libraries or create new ones using a variety of tools including Excel, Matlab, or Keysight's N7660C MultiEmitter Scenario Generation software or Z9500A Simulation View software¹.

See, Capture, Analyze, and Understand Complex Environments

Analyzing and scoring EW stimulus and electronic attack resources presents unique challenges, as the high-density environments feature wide-bandwidth and complex pulse modulation types. With Keysight's COTS analysis hardware, including signal analyzers, oscilloscopes, and digitizers, you can capture and characterize the EW environment up to 110 GHz with wide modulation bandwidths.

The key is pulse analysis software. Using the Keysight N9067C and 89601B software, you can differentiate threats with pulse-scoring filters based on characteristics such as pulse width, PRI, and modulation type (including linear and non-linear modulation). You also can capture long scenarios with efficient memory usage and make correlations and sidelobe measurements.

Dual-domain analysis with narrow bandwidth enables frequency domain analysis while wider bandwidth targets time-domain analysis. Using the 89601B software, you can compare sequential pulses to assist with radar output waveform validation with Pulse Similarity Scores. Pulse Train Searches ensure that radar mode changes happen as expected.

Record, Score, and Analyze System Outputs

In the dynamic EM environment, EW systems must confront an onslaught of new signals. The radar recorder can record and analyze pulsed signals in real-time, making it the ideal multi-channel system to witness and verify the output of electronic attack systems. Using real-time measurement and PDW scoring, Keysight's radar recorder quickly verifies measured pulses. It increases confidence in testing while significantly improving recorder scalability, capability, and support.

For example, the Z2099B family's wideband, multi-channel design allows simultaneous two-channel recording for analysis on both inputs and outputs. Real-time measurement and PDW scoring increase confidence in testing while introducing the rapid verification of measured pulses. You can easily view and analyze large amounts of PDW data via the analysis software. Staggered channel capture allows for simultaneous recording and data offloading and analysis. This system family ranges from small and transportable to fill systems, allowing the radar recorder to scale easily.

¹ N7660C and Z9500A software are subject to US ITAR export regulations. For more information, contact your Keysight sales representative.

COTS EW Signal Generation and Analysis Building Blocks

Keysight provides commercially available building blocks to create EW threat simulation and analysis systems. This includes solutions with:

- N5193A/94A Agile signal generators for multi-channel and multi-port threat simulations
- Arbitrary waveform generators for threat simulation for baseband or wideband verification
- Oscilloscopes, signal analyzers, and digitizers for wideband signal analysis
- Flexible FPGA tools and storage and streaming options for closed-loop simulations

Flexible EW Threat Simulation and Analysis Solutions

Keysight has a long history in measurement and calibration science. Work with our team of experts to configure and design a scalable and flexible EW test system. Our solutions include full system integration, automated multi-source, and system-level calibration.

- Create high-density, AoA simulations with flexible multi-port configurations
- Ensure coherence across multiple sources with calibration of amplitude, phase, and time
- Threat simulators compatible with MESH software or other dynamic PDW-based scenario generation systems
- Capture the signal environment using a multi-channel, wide-bandwidth streaming recording of RF and processed signals
- The integrated combination of hardware, firmware, and software performs signal selection, downconversion, digitization, signal processing, and data storage
- Apply post-capture analysis software to RF test and signal-processed recordings

Real-Time Sequenced PDW Files

Often, real-time sequenced streaming is necessary for EW signal generation. For example, such capability is useful during an over-the-air test or open range test to simulate multiple ground-based radars. The UXG signal generator synchronizes to any time module that can output PPS - for example, GPS. With multiple boxes synchronized, they are triggered at the same universal time clock. As a result, the operator can do the following:

- Control several UXG stacks located over a significant distance from one central location
- Use the same PDW library and threat simulation files from early prototype and system integration testing to verify in-flight/operation receiver & processor effectiveness and stability and
- Play the same files and simulations at the corresponding UTC across different labs or locations



Pre-Mission Go/No-Go Testing

Once a system is deployed into the field, there may be a need to perform pre-mission tests to verify operational readiness. Keysight's FieldFox handheld microwave analyzers offer benchtop performance out in the field across multiple terrains and extreme environments including clean room to desert, sea, tropics, and arctic. Gain confidence in mission-critical measurements including:

- **Receiver Test**
 - noise figure
 - functional test with CW source
- **Emitter Verification**
 - verify signal output and characteristics with a power meter, spectrum analyzer, and real-time spectrum analyzer to 50 GHz
 - pulse profiling to 40 GHz with USB peak power sensor
- **Op check entire RF chain or individual components, radiated or closed-loop**
 - antennas, cables, converters, amplifiers
 - distance-to-fault and Time domain reflectometry (TDR)
- **Op Check GPS**
 - evaluate carrier-to-noise density (C/N) and distribution amplifiers

Support

Keysight offers a broad portfolio of services and support to assist engineers working on electronic warfare programs. We understand that engineers count on accurate, repeatable measurements to ensure mission success while meeting budget and schedule requirements. Inaccurate measurements and system downtime affect yield and the risk of a device failing during operation. The emergence of new and unique threats drives a need for constant modernization.

To address this challenge, you can:

- Implement an optimal migration strategy with Technology Refresh Services to modernize test equipment to the latest technology as soon as it is available with upgrade and Trade-In Services
- Have confidence that your instruments are performing to specification by utilizing Keysight's global network of service centers across multiple countries
- Avoid the need to disassemble and reassemble test systems and improve true yields with System Calibration Services

One of the long-standing trends in the industry is the need for long-term support for sometimes multi-decade programs with little to no budget for upgrades:

- Use Extended Support plans to ensure the availability of parts for repair and calibration procedures for legacy instruments
- Take advantage of Keysight's expertise in test and sustainment planning through Consulting Services
- Leverage One-Stop Calibration Services to reduce logistical complexity and lower costs with one point of contact for the calibration of all your test assets

As the demand for better performance and newer technologies continually drives more complex designs, with narrow test margins and longer test times. The complex test systems composed of instruments from multiple vendors must be managed. To help mitigate these challenges, you can:

- Dramatically reduce test times and improve test system efficiency through Keysight Process Analysis Services
- Improve operational performance and ensure ongoing accuracy through accredited and standards lab calibration on Keysight and non-Keysight electronic instruments
- Manage downtime with loaner services, onsite calibration, and onsite resident professionals
- Minimize risk and reduce costs by leveraging System Calibration Services to ensure that your test systems are performing to the test system uncertainty we calculate

Helping You Prevail in the EM Environment

With the accelerating evolution of EW threats, dramatic improvements in tests and evaluation are not optional. Welcome to a new era: Keysight is stepping forward as a commercial collaborator, creating and delivering the rapidly adaptable solutions you need to succeed far into the future. Our mission is to work with your team to ensure enhanced realism and greater confidence.

Engage with Keysight — solutions and services — and take your lab to the next level.

Note: The EW software is subject to ITAR export regulations. For more information, a live demonstration, or a trial license, please contact your Keysight sales representative.



Appendix

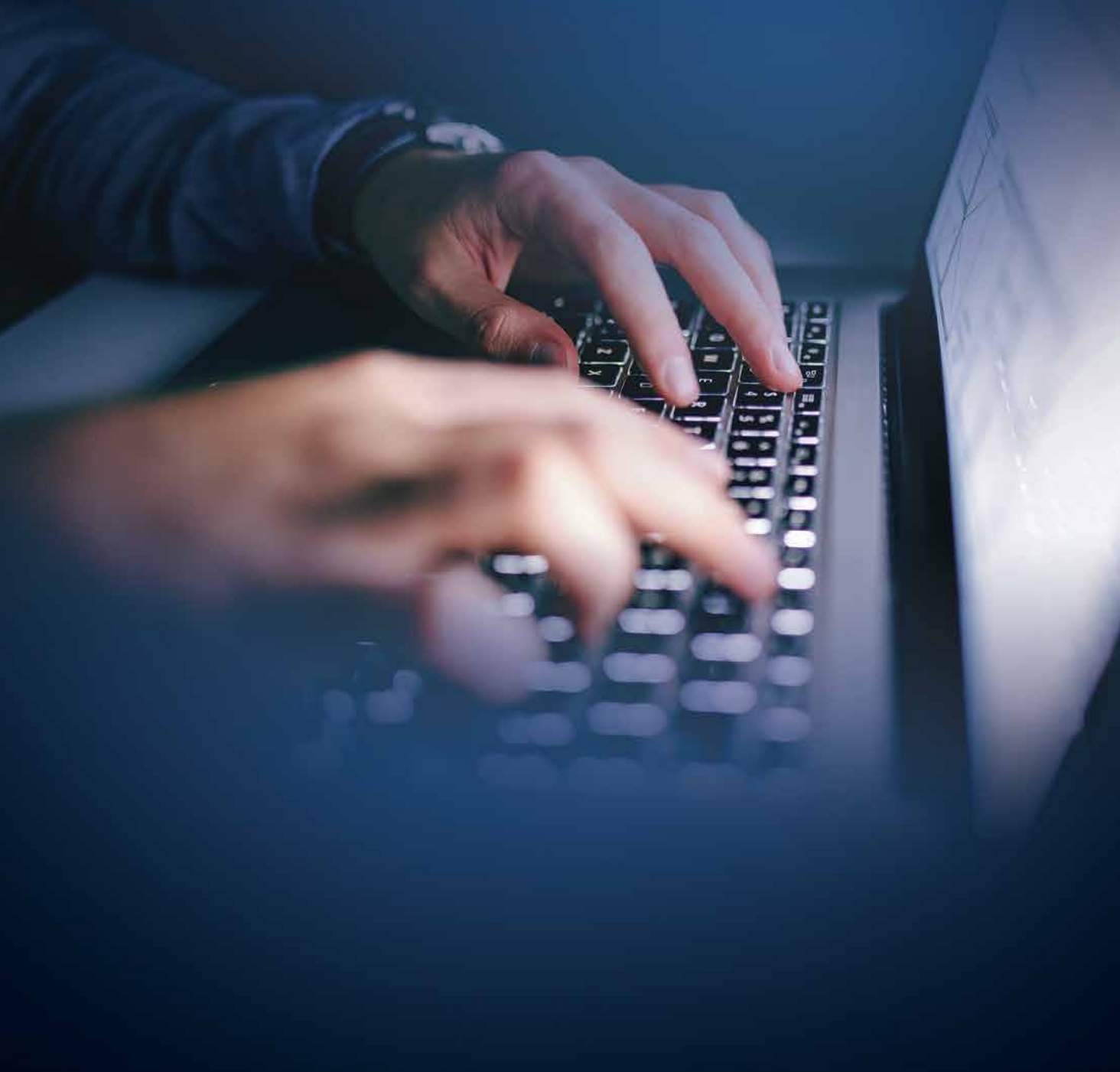

Acronyms

AAI	Air-to-Air Intercept	DAC	Digital to Analog Converter
ACPR	Adjacent Channel Power Ratio	DANL	Displayed Average Noise Level
ADC	Analog-To-Digital Converter	DBF	Digital Beam Forming
ADS	Advanced Design System	DDS	Direct Digital Synthesis
ADT	Automatic Detection and Tracking	DOA	Direction of Arrival
AESA	Active Electronically Scanned Array	DRFM	Digital Radio Frequency Memory
AEW	Airborne Early Warning	DTM	Digital Terrain Model
AFC	Automatic Frequency Control	DUT	Device Under Test
AFR	Automatic Fixture Removal	EA	Electromagnetic Attack
AGC	Automatic Gain Control	ECC	Error Correcting Code
AI	Artificial Intelligence	ECCM	Electronic Counter-Countermeasures
AM	Amplitude Modulation	ECM	Electronic Counter Measure
AoA	Angle of Arrival	EDA	Electronic Design Automation
APAR	Active Phase Array Radar	EIRP	Effective Isotropic Radiated power
AUT	Amplifier Under Test	ELINT	Electronic Intelligence
AWG	Arbitrary Waveform Generator	EMS	Electromagnetic Spectrum
AWGN	Additive White Gaussian Noise	EMV	Electromagnetic Vulnerability
BITE	Built in Test Equipment	EOB	Electronic Order of Battle
BSD	Blind Spot Detection	EPM	Electronic Protective Measures
BW	Bandwidth	ESA	Electronically Steerable Array
CAD	Computer Aided Design	ESM	Electronic (Warfare) Support Measures
CEMA	Cyber and Electromagnetic Activities	ETP	Equivalent Transmitter Power
CFAR	Constant False Alarm Rate	EVM	Error Vector Magnitude
COHO	Coherent Oscillator	EW	Electronic Warfare
COTS	Commercial off the Shelf	FAR	False Alarm Rate
CW	Continuous Wave	FCA	Frequency Converter Application

FCC	Fault Collection Unit	MMIC	Microwave Monolithic Integrated Circuit
FCW	Forward Collision Warning	MSSR	Monopulse Secondary Surveillance Radar
FDOA	Frequency Difference of Arrival	MTD	Moving Target Detection
FFT	Fast Fourier Transform	MTI	Moving Target Indication
FM	Frequency Modulation	MTTR	Multi Target Tracking Radar
FMCW	Frequency Modulated Continuous Wave	NFA	Noise Figure Analyzer
FOM	Frequency Offset Mode	NIST	National Institute of Standards and Technology
FPGA	Field Programmable Gate Array	NVNA	Non-Linear Vector Network Analyzer
FSK	Frequency Shift Keying	OCR	Optical Character Recognition
GCA	Ground-Controlled Approach	OTH	Over-The-Horizon
GPR	Ground Penetrating Radar	PA	Power Amplifier
GTC	Gain Time Control	PAR	Phased-Array-Radar
HIL	Hardware in Loop	PAR	Precision Approach Radar
HPA	High Power Amplifier	PDW	Pulse Descriptor Word
IF	Intermediate Frequency	PDF	Probability Distribution Function
IFF	Identification Friend or Foe	PESA	Passive Electronically Scanned Array
IMD	Inter Modulation Distortion	PLL	Phase Locked Loop
ISL	Integrated sidelobe level	PNTS	Phase Noise Test System
LNA	Low Noise Amplifier	PRF	Pulse Repetition Frequency
LO	Local Oscillator	PRI	Pulse Repetition Interval
LPF	Low Pass Filter	PRN	Pseudo-Random-Noise
LPI	Low Probability of Intercept	PRT	Pulse Repetition Time
LRU	Line-Replaceable Unit	PSD	Power Spectral Density
LVDS	Low Voltage Differential Signaling	PSL	Peak sidelobe level
MBE	Model Based Engineering	PW	Pulse Width
MDF	Mission Data File	RADAR	Radio Detection and Ranging
MFR	Multi-Function Radar	RBW	Resolution Bandwidth
MIMO	Multiple Input Multiple Output	RCS	Radar Cross-Section

RDF	Range and Direction Finding	STC	Sensitivity Time Control
RF	Radio Frequency	SUT	System Under Test
RS	Ramp Slope	T/R	Transmit/Receive
RWR	Radar Warning Receiver	TBP	Time-Bandwidth Product
RX	Receiver	TDOA	Time Difference of Arrival
SAM	Surface-to-Air Missile	TDR	Time Domain Reflectometer
SAR	Synthetic Aperture Radar	TMA	Terminal Maneuvering Area
SDR	Software Defined Radio	TOI	Third Order Intercept
SFDR	Spurious Free Dynamic Range	TRL	Thru, Reflect, Line(calibration)
SIF	Selective Identification Feature	TRM	Transmitter-Receiver Module
SMC	Scalar Mixer Calibration	TWT	Traveling Wave Tube
SMR	Surface Movement Radar	TX	Transmitter
SNR	Signal-to-Noise Ratio	ULA	Uniform Linear Array
SOLT	Short, Open, Load, Thru (calibration)	UUT	Unit Under Test
SPI	Serial Peripheral Interface	UWB	Ultra-Wideband
SSA	Signal Source Analyzer	VCO	Voltage Controlled Oscillator
SSB	Single Side Band	VMC	Vector Mixer Calibration
SSPA	Solid-State Power-Amplifier	VNA	Vector Network Analyzer
SSR	Secondary Surveillance Radar	VSA	Vector Signal Analyzer
STALO	Stable Local Oscillator	VSG	Vector Signal Generator
STAP	Space-Time Adaptive Processing	VSWR	Voltage Standing Wave Ratio

(The following acknowledgement applies to the acronyms section only)

Publisher: Christian Wolff (Revised by Karina Hoel and Keysight Technologies)

Text is available under the GNU Free Documentation License (<https://www.gnu.org/licenses/fdl-1.3.html>), and the Creative Commons Attribution-Share Alike 3.0 Unported (CC BY-SA 3.0) (<https://creativecommons.org/licenses/by-sa/3.0/>)license, additional terms may apply.



Additional Resources

[Keysight Technologies Electronic Warfare Test and Evaluation Solutions, 5992-3476EN](#)

[Multichannel Coherent Electronic Warfare Analysis Solution, 3121-1019EN](#)

[Electronic Warfare Threat Simulation Solutions Catalog, 7120-1247EN](#)

[PathWave Design Software, 5992-4019EN](#)

[PathWave System Design, 3121-1074EN](#)

[Electronic Warfare Signal Generation: Technologies and Methods, 5992-0094EN](#)

[N5193A UXG Agile Signal Generator Data Sheet, 5992-0092EN](#)

[N5194A UXG Agile Vector Adapter Data Sheet, 5992-2228EN](#)

[Signal Studio for Multi-emitter Scenario Generation, 5992-0405EN](#)

[Creating Multi-Emitter Scenarios for Radar and Electronic Warfare \(EW\) Testing, 5992-2902EN](#)

[Z9500A Keysight Threat Simulation Overview, 5992-4339EN](#)

[N9040B UXA Signal Analyzer Data Sheet, 5992-0090EN](#)

[N9067C Pulse Analysis Application Technical Overview, 5992-1384EN](#)

[Pulse Analysis – PathWave Vector Analysis \(89600 VSA\) Technical Overview, 5992-4197EN](#)

[Radar Measurements, 5989-7575EN](#)

[Measuring Radar Signals with Vector Signal Analyzers and Wideband Instruments, 5992-1580EN](#)

[PNA and PNA-X Series Microwave Network Analyzers, 5990-4592EN](#)

[Field Fox Handheld Analyzers Technical Overview, 5992-0772EN](#)

[Techniques for Precision Validation of Radar System Performance in the Field, 5991-4107EN](#)

[Keysight Care, 5992-3373EN](#)

